



SERVICE MANUAL

FREESTYLE EVOLUTION

CAREFREE STYLE CODE “IJ”

RV

12V MOTORIZED ROOF MOUNTED BOX AWNING



Read this manual before installing or using this product. Failure to follow the instructions and safety precautions in this manual can result in personal injury and/or cause the product to not operate properly.



These instructions apply to all models listed. Details and procedures unique to a specific model are labeled appropriately.

TABLE OF CONTENTS

- Standard System Adjustments 1**
 - Manual Override 1
 - Adjusting the Pitch 1
 - Adjusting the Motor Limits 2
 - Extend Limit Switch 2
 - Replacement Tubular Motor Limit Switches (Models prior to 2024 without extend limit switch) 2
 - Standard Maintenance 3
 - Fabric Care 3
 - Mildew 3
 - Pooling 3
 - Motor Maintenance 3
 - Arm Noise 3
- Canopy Replacement – Right Angle Gear Motor 4**
- Canopy Replacement – Tubular Motor 7**
- Outer Spring Arm Replacement 9**
- Motor Replacement 11**
 - Preliminary Steps (All Configurations) 11
 - Replacing the Motor (Right Angle Gear) 11
 - Replacing the Motor (Tubular) 13
 - BT12 System 14
 - DRC12 System 14
- Part Number Listing 15**
 - Part Number/Serial Number Location 15
 - Illustrated Parts List 15
 - Freestyle RM Bracket Kits 17

NOTICES AND DISCLAIMERS

TRADEMARKS

The **Bluetooth**® word mark and logos are registered trademarks owned by the Bluetooth SIG, Inc. Use of such marks by Carefree of Colorado is under license.

Other trademarks and trade names are those of their respective owners.

STATEMENTS OF COMPLIANCE

- BT12 Control Module
- BT Motion Sensor
- BT Remote

The DRCHUB contains transmitter module FCC ID:2AA9B04; IC:12208A-04.

FCC and IC identification numbers are located on the exterior surfaces of the individual components.

FCC COMPLIANCE

These devices comply with Part 15 of the FCC rules. Operation is subject to the following two conditions: (1) These devices may not cause harmful interference and, (2) These devices must accept any interference received, including interference that may cause undesired operation.

NOTE: This equipment has been tested and found to comply with the limits for a Class B digital device, pursuant to part 15 of the FCC rules. These limits are designed to provide reasonable protection against harmful interference in a residential installation. This equipment generates, uses and can radiate radio frequency energy and, if not installed and used in accordance with the instructions, may cause harmful interference to radio communications. However, there is no guarantee that interference will not occur in a particular installation. If this equipment does cause harmful interference to radio or television reception, which can be determined by turning the equipment off and on, the user is encouraged to try to correct the interference by one or more of the following measures:

- Reorient or relocate the receiving antenna.
- Increase the separation between the equipment and receiver.
- Connect the equipment into an outlet on a circuit different from that to which the receiver is connected.
- Consult the dealer or an experienced radio/TV technician for help.

Any changes or modifications not expressly approved by the party responsible for compliance could void the user's authority to operate the equipment.

IC COMPLIANCE

These devices comply with Industry Canada license-exempt RSS standard(s). Operation is subject to the following two conditions: (1) These devices may not cause harmful interference and, (2) These devices must accept any interference received, including interference that may cause undesired operation.

Ces appareils sont conformes aux normes RSS exonérées de licence d'Industrie Canada. L'opération est soumise aux deux conditions suivantes: (1) Ces appareils ne doivent pas causer d'interférences nuisibles et, (2) Ces appareils doivent accepter toute interférence reçue, y compris les interférences pouvant entraîner un fonctionnement indésirable.

FCC/IC RADIATION EXPOSURE STATEMENT

- BT12 Control Module
- BT Motion Sensor

This equipment complies with FCC and IC radiation exposure limits for an uncontrolled environment. The minimum distance between the radiator and people is designed to be 20cm when installed and operated.

Cet équipement est conforme aux limites d'exposition aux radiations FCC et IC pour un environnement non contrôlé. La distance minimale entre le radiateur et les personnes est de 20cm lorsqu'installé et utilisé.

- BT12 Remote

This equipment complies with FCC and IC radiation exposure limits for an uncontrolled environment. The minimum distance between the radiator and people is designed to be 5mm when operated.

Cet équipement est conforme aux limites d'exposition aux radiations FCC et IC pour un environnement non contrôlé. La distance minimale entre le radiateur et les personnes est de 5mm (à l'exclusion des extrémités: mains, poignets, pieds et chevilles) lors de l'utilisation.

DISCLAIMERS

The BT12, DRC12 and the Carefree Connects Mobile Apps are products of Carefree of Colorado, located in Broomfield, Colorado, USA. The information contained in or disclosed in this document is considered proprietary to Carefree of Colorado. Every effort has been made to ensure that the information presented in the document is accurate and complete. However, Carefree of Colorado assumes no liability for errors or for any damages that result from the use of this document.

The information contained in this manual pertains to the current components and software listed on the title page. Carefree of Colorado reserves the right to cancel, change, alter or add any parts and procedures, described in this manual, without prior notice.

Carefree of Colorado agrees to allow the reproduction of this document for use with Carefree of Colorado products only. Any other reproduction or translation of this document in whole or part is strictly prohibited without prior written approval from Carefree of Colorado.

SERVICE AND SUPPORT

	www.carefreeofcolorado.com www.carefreeofcolorado.com/rv-products/carefree-connects/
	customerservice@carefreeofcolorado.com
	Carefree of Colorado 2145 W. 6 th Ave. Broomfield, CO 80020

SAFETY INFORMATION



This is the safety alert symbol. It is used to alert individuals to potential personal injury hazards. Obey all safety messages that follow this symbol to avoid possible personal injury or death.



Indicates a hazardous situation, which if not avoided, could result in death or serious bodily injury.



Indicates a hazardous situation, which if not avoided, may result in minor or moderate bodily injury.



Indicates a situation that may result in equipment-related damage.

General Safety:



This product can expose you to chemicals including Di-isodecyl phthalate (DIDP), Vinyl Chloride and Formaldehyde, which are known to the state of California to cause cancer or birth defects or other reproductive harm. For more information visit www.P65warnings.ca.gov



Shock Hazard. Always disconnect battery or power source before working on or around the electrical system.



Always wear appropriate safety equipment (i.e. goggles).



Always use appropriate lifting devices and/or helpers when lifting or holding heavy objects.



When using fasteners, do not over tighten. Soft materials such as fiberglass and aluminum can be "stripped out" and lose the ability to grip and hold.

PRODUCT OVERVIEW

The Freestyle Evolution Awning is a state of the art lateral arm awning. When retracted, the housing provides protection against the elements while the streamlined styling blends in with the vehicle appearance. The full tension canopy fabric allows the awning to be partially or fully extended for best shade coverage.

Each unit is equipped with lateral support arms. No vertical arms interfere with coach sidewalls, custom graphics or equipment that may be mounted on the sidewalls.

Freestyle Awning Specifications:

- Fully retractable and self-storing;
- The sealed awning motor operates on standard 12VDC (range 10VDC to 14VDC);
- Case and frame are constructed of high-strength aluminum extrusions, protected with a polyester paint finish;
- BT12 Wireless Awning Control System is standard.

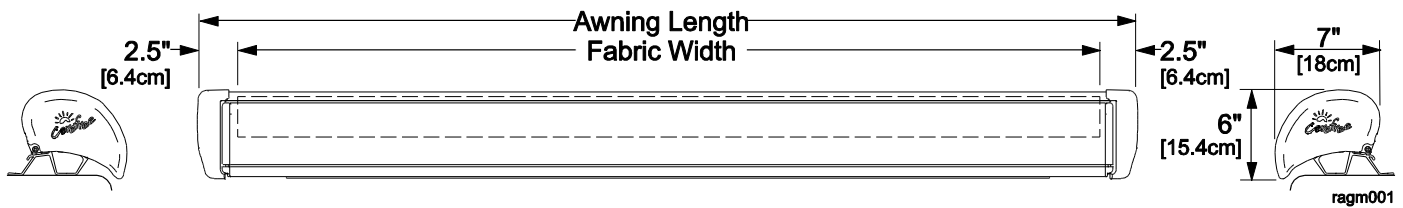

NOTE: Dimensions shown are approximate. Dimensions may vary based on specific installations.

SPECIFICATIONS

Lengths:	centimeters	200 - 241	244 - 254	257 - 297	300 - 500
	inches	79 - 95	96 - 100	101 - 117	118 - 197
Extension:		152cm (60")	180cm (72")	200cm (80")	250cm (98")

LEADING EDGE POSITION ACTUATION AND CONTROL

Power:	Lateral Arm Spring	<i>Minimum Tension</i>	Open
Position Control:	12V Motorized		
Controller:	BT12, DRC12		

MOTOR SPECIFICATIONS

Motor Type:	Tubular, Right Angle Gear Motor		
Power:	12VDC	<i>Minimum: 10VDC</i>	<i>Output: 30 Watts</i>
	<i>Nominal Current: 2.5Amps</i>		<i>Max Current: 14Amps (stall @ min voltage)</i>
Power Source:	Motor and controls are routed and hardwired into the vehicle's 12V system		
Torque	<i>Continuous: 6Nm/4.5 ft-lbs.</i>		
Speed	24 rpm		

COLORS AVAILABLE

Case	Satin, White or Black
Fabric:¹	Vinyl or Woven Acrylic

Special Note: Dimensions are provided in centimeters. Conversion formulas are provided below;

$$\text{Inches} = \frac{\text{Centimeters}}{2.54} = \frac{\text{Millimeters}}{25.4}$$

$$\text{Centimeters} = \text{Inches} \times 2.54 \quad \text{Millimeters} = \text{Inches} \times 25.4$$

STANDARD SYSTEM ADJUSTMENTS

MANUAL OVERRIDE

If power to the vehicle is not available, the awning can be safely retracted using the manual override located on the idler end of the case.

NOTE: This procedure cannot be used to extend the awning.

1. Remove the outer endcap on the idler side and save.
2. Insert a 3/8" socket drive extension and handle into the square drive hole inside the inner end cap.
3. Turn the handle to match the direction arrows until the awning is retracted.
4. Replace the outer cap.

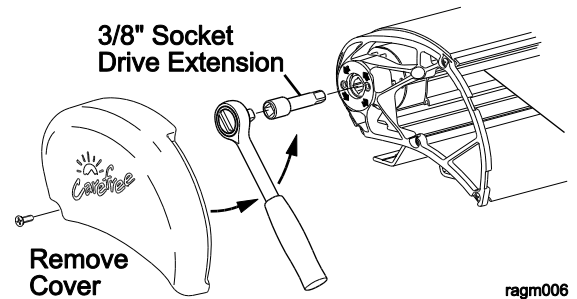

ragm006

NOTICE After closing the awning with the manual override, the lead rail may move out from the case 1/4" -1/2". This is normal and the awning is secure for travel until power is restored or repairs are completed. Do not attempt to force the lead rail in with the override, serious damage can occur to the awning.

ADJUSTING THE PITCH

The awning opens and closes with a steep pitch. On low profile vans, the leading edge of the awning may hit the top of the sliding door if the door is open while extending or retracting the awning. To prevent this, the lower limit of the pitch can be adjusted upwards.

1. Open the awning to access the screws located on the side of the arm case knuckles.
2. For Original Configurations:
 - 2.1. Using an 8mm allen wrench, loosen the 2 screws on the side of the case connector.
 - 2.2. Have a second person lift the lead rail to the desired height.
 - 2.3. When the pitch is set at the desired angle, tighten the screws. Torque to 50 ft-lbs.
3. For Current Configurations:
 - 3.1. Loosen the screw on the side of the case connector.
 - 3.2. Turn the 10mm (5mm allen wrench) clockwise to raise the pitch or counterclockwise to lower the pitch.
Tip: When raising the pitch have a second person lift up on the lead rail.
 - 3.3. When the pitch is set at the desired angle, tighten the screw. Torque to 25-30 ft-lbs.
4. Repeat for each arm. Ensure that the lead rail is parallel with the awning case.

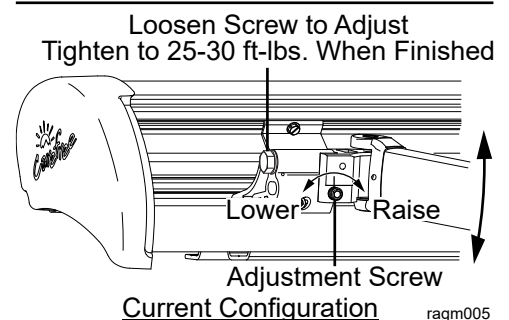
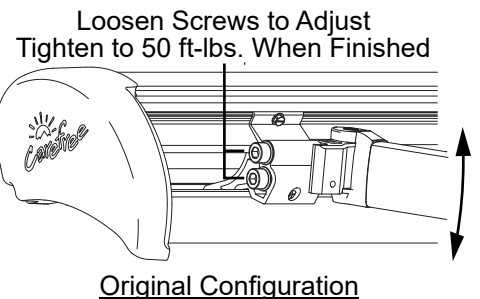

ragm005

NOTE: The lead rail is self-adjusting. No adjustment is required to the lead rail when the pitch is changed.

ADJUSTING THE MOTOR LIMITS

The tubular motor limit switches are preset at the factory for best operation of the awning. There are no limit switches on the right angle gear motor. The retract function is controlled by the control system and both motor types use the "Extend Limit Switch" to adjust the maximum extension of the awning.

Extend Limit Switch

A separate Extend Limit Switch disables the extend function when the awning is fully extended. This prevents the awning from overextending and can be adjusted so that the canopy is tight when the awning is extended.

The switch is located on the arm knuckle closest to the motor (i.e. right knuckle for RH motor, left knuckle for LH motor).

To adjust the extension:

1. Open the awning to access the switch.
2. Loosen the screw.
3. Move the switch toward the arm to decrease the extension.
4. Move the switch away from the arm to increase the extension.

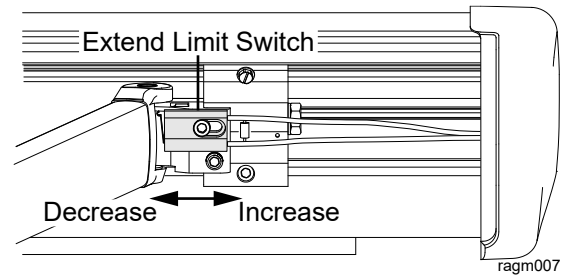

Replacement Tubular Motor Limit Switches (Models prior to 2024 without extend limit switch)

When replacing a tubular motor, it may be necessary to adjust the motor's limit switches to allow the control system to correctly monitor and control the awning.

The limit switches are located inside the motor endcap. To access the switches remove the outer motor endcap.

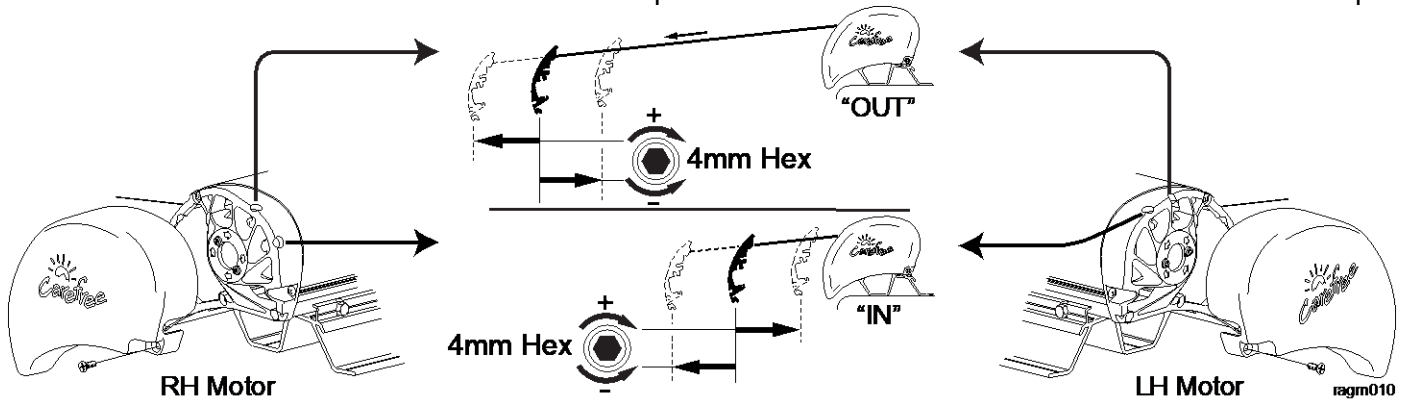

IN LIMIT SWITCH

The "IN" limit switch on the tubular motor is not used when the BT12 system is installed. The system electronics monitors the motor and shuts the motor off when the awning is fully retracted.

If the "IN" limit switch is out of adjustment, the motor may shut off before the awning is fully closed. If this occurs, turn the "IN" adjustment screw **CLOCKWISE** several dozen times. The screw position should not match the closed position. The BT12 electronics controls the closed position.

OUT LIMIT SWITCH

The "OUT" limit switch on the tubular motor is not used when the BT12 system is installed. The Extend Limit Switch disables the extend function when the awning is fully extended.

If the "OUT" limit switch is out of adjustment, the motor may shut off before the awning is fully extended. If this occurs, turn the "OUT" adjustment screw **CLOCKWISE** several dozen times. The screw position should not match the open position. The Extend Limit Switch controls the open position.

STANDARD MAINTENANCE

Maintaining a Carefree Awning is easy. Just follow these basic steps:

- Always operate the awning according to the instructions.
- Periodically check that the fasteners are tight. Tighten if necessary.
- Keep the awning fabric and arms clean.

Fabric Care

NOTICE Do not use oil based cleaners or any caustic, granulated, or abrasive type cleaners on your Carefree product.

1. One of the best ways to keep the fabric looking good and to delay the need for deep or vigorous cleanings is to hose fabrics off on a monthly basis with clear water. This practice will help prevent dirt from becoming deeply imbedded in the fabric. In most environments, a thorough cleaning will be needed every two to three years.
2. When it's time for a thorough cleaning, the fabric can be cleaned while still on the awning frame.
 - For Vinyl Fabric – Use a soft brush and warm water with soap.
 - For Acrylic Fabric – Use a stiff brush and warm water with soap.
3. When cleaning the fabric, it is important to observe the following:
 - Always use a natural soap, never detergent.
 - Water should be cold to lukewarm, never more than 100°F.
 - Air-dry only. Never apply heat to the fabric.
 - Always allow the fabric to dry thoroughly before rolling up the awning.

Mildew

Mildew is a fungus growth that looks like dirt. Vinyl coated polyester fabrics are mildew resistant because of a chemical biocide in the vinyl coating. Under ordinary conditions, mildew will not appear. However, in areas where high temperature and humidity are common, mildew can be a problem and required the material to be washed more frequently. Thoroughly rinse the fabric with clean water and allow to air dry completely before rolling up the awning.

Pooling

When water collects on the top of the fabric, this is known as "pooling". This can occur during inclement weather or if a running air conditioner discharges over the awning. The water is dumped when the awning is retracted. It is recommended that if water accumulates on the top; retract the awning in steps (8"-12") to dump the water. This will help prevent the fabric from stretching or distorting.

The effects of wind and rain on an awning are unpredictable. Severe damage to the awning and the vehicle may result. IF WIND OR EXTENDED PERIODS OF RAIN ARE EXPECTED, ROLL UP THE AWNING AND SECURE FOR TRAVEL.

Motor Maintenance

- Check all wiring and connections for wear. Repair when needed.
- Check that the sealant is providing a good seal and no water is accumulating on the wiring.

Arm Noise

After a period of use, the arm knuckle joints may slide together slightly making a squeaking or squealing noise; this is normal and not a reason for concern. To reduce the sound, apply a few drops of multi-purpose oil (3-IN-1[®] ¹ or equivalent) on the knuckle joint seams. Operate the awning and repeat 3-4 times to allow the oil to penetrate into the joint.

¹ 3-IN-1[®] is a registered trademark of the WD-40 company.

CANOPY REPLACEMENT – RIGHT ANGLE GEAR MOTOR

This procedure requires two people.

1. Open the awning 18"-24".
2. Disconnect power to the awning.
3. Carefully push the lead rail toward the case so that the arms collapse and the fabric is slack.
4. Hold the lead rail in this position and firmly tie the elbows of the spring arms together. Use a minimum 1/2" rope - do not use bungee cords. When tying the rope, use a non-slip knot such as a square knot or equivalent.

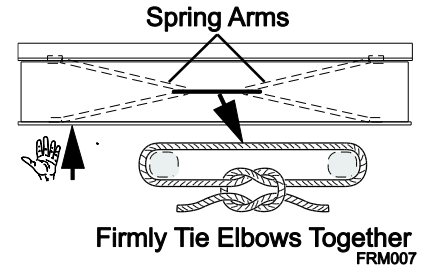

CAUTION

Failure to secure the lead rail as described

will allow the spring arms to unexpectedly extend out possibly causing personal injury and damage to the awning.

NOTE: The illustrations show the RH motor configuration. Instructions are the same for LH motor configurations.

5. On the idler side:
 - 5.1. Remove the fabric retaining screw from the lead rail endplate.
 - 5.2. Remove the outer end cap and set aside.
 - 5.3. Disconnect the motor quick connects.
 - 5.4. Remove the two (2) cover screws from the end plate.

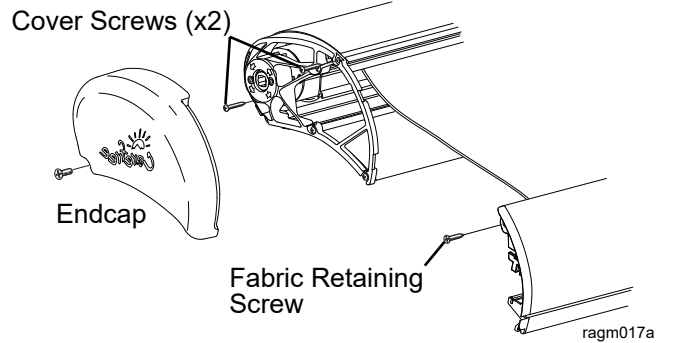

6. On the motor side:
 - 6.1. Remove the lead rail endplate.
 - 6.2. Remove the outer end cap and set aside.
 - 6.3. Take a picture of the motor wires and label them to aid reassembly. Some models use a cross-over wire depending on who manufactured your coach so colors may not match diagrams. Disconnect the motor wires.
 - 6.4. Remove the five (5) endplate screws.
 - 6.5. Rotate the top cover back and out of the way.
 - 6.6. Remove the roller tube attach screw.
 - 6.7. Remove the case endplate and motor.

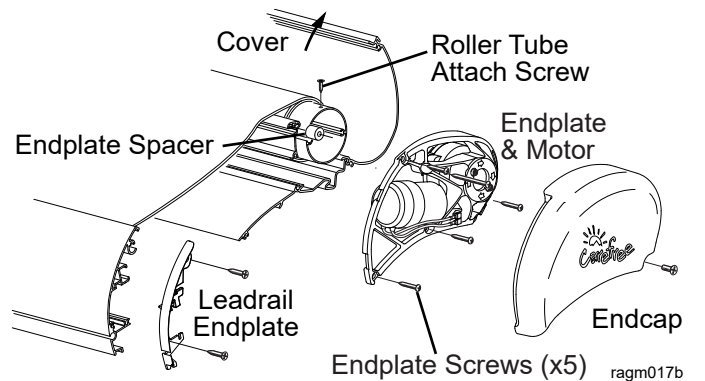

NOTE: It is not necessary to remove the motor from the endplate.

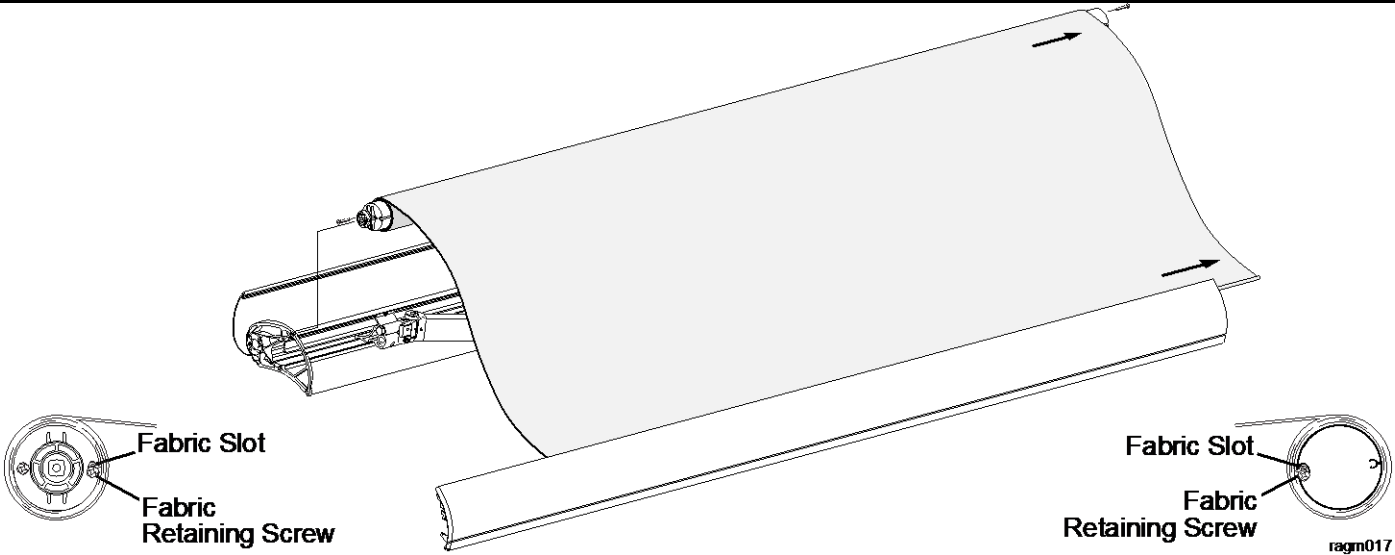

7. Lift the roller tube and fabric up and out of the case.
8. Remove the fabric retaining screws from the roller tube and idler end plug.
9. Pull the roller tube out of the case while pulling the fabric from the lead rail.
10. Note the orientation of the old canopy then unwrap and remove from the roller tube.
11. Unfold the replacement fabric then slide the new fabric onto the roller tube until the fabric and roller tube are centered.

NOTICE While the awning fabric is fairly robust, use care not to snag the new fabric while sliding it into the roller tube and lead rail.

Tip: Lightly spraying the slots with a dry silicone lubricant will help the fabric slide into the slot without staining the material.

12. Secure the fabric on the roller tube with a retaining screw through the roller tube (motor side).
NOTE: The screw must be positioned to thread into the metal of the roller tube slot and the edge of the canopy polycord.
13. On the idler side, pull the fabric smooth in the roller tube then secure with a retaining screw through the end plug.
14. Roll the fabric onto the roller tube leaving enough material to reach between the case and the lead rail.
15. Slide the fabric into the lead rail and the roller tube into the case.
16. Seat the idler into the endplate.
17. On the motor side:
 - 17.1. Insert the motor and drive into the roller tube.
 - 17.2. Attach the end plate with motor to the case with the screws removed previously.
 - 17.3. Attach the roller tube to the motor with the roller tube attach screw removed previously.
 - 17.4. Attach the motor and harness wires. Fold and tuck the wires and connectors to fit inside the end cap.

NOTICE Wire colors do not match between motor, limit switch and harness. Use the wiring diagram in controller installation instructions to ensure correct connections for the motor configuration.

18. Restore power to the awning.
19. Open and close the awning to confirm that the fabric rolls and unrolls squarely. Adjust the fabric position in the lead rail as required.
20. Attach the motor side lead rail end plate.
NOTE: The top screw of the lead rail end plates secures the fabric in the lead rail. The screw should be positioned to thread into the metal of the lead rail and the edge of the polycord.
21. Attach the fabric retaining screw into the idler side lead rail end plate.
22. Close and secure the cover. There are two screws on each end of the awning.
23. Attach the end caps.
24. After installing the canopy, it may be necessary to adjust the extend limit switch. Refer to "Adjusting the Motor Limits" on page 2.

CANOPY REPLACEMENT – TUBULAR MOTOR

This procedure requires two people.

1. Open the awning 18"-24".
2. Disconnect power to the awning.
3. Carefully push the lead rail toward the case so that the arms collapse and the fabric is slack.
4. Hold the lead rail in this position and firmly tie the elbows of the spring arms together. Use a minimum 1/2" rope - do not use bungee cords. When tying the rope, use a non-slip knot such as a square knot or equivalent.

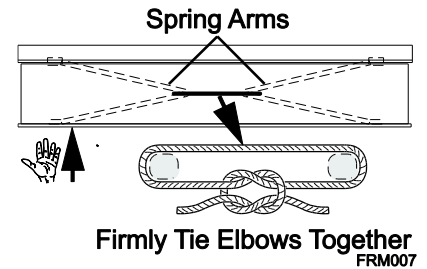

CAUTION

Failure to secure the lead rail as described will allow the spring arms to unexpectedly extend out possibly causing personal injury and damage to the awning.

NOTE: The illustrations show the RH motor configuration. Instructions are the same for LH motor configurations.

5. On the motor side:
 - 5.1. Remove the fabric retaining screw from the lead rail endplate.
 - 5.2. Remove the outer end cap and set aside.
 - 5.3. Disconnect the motor quick connects.
 - 5.4. Remove the two (2) motor screws and two (2) cover screws from the end plate.

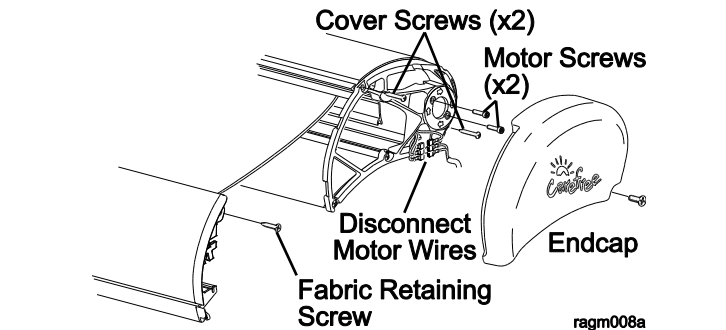

6. On the idler side:
 - 6.1. Remove the lead rail endplate and set aside.
 - 6.2. Remove the outer end cap and set aside.
 - 6.3. Remove the five (5) screws and case endplate. Set parts aside.
7. Rotate the top cover back and out of the way.

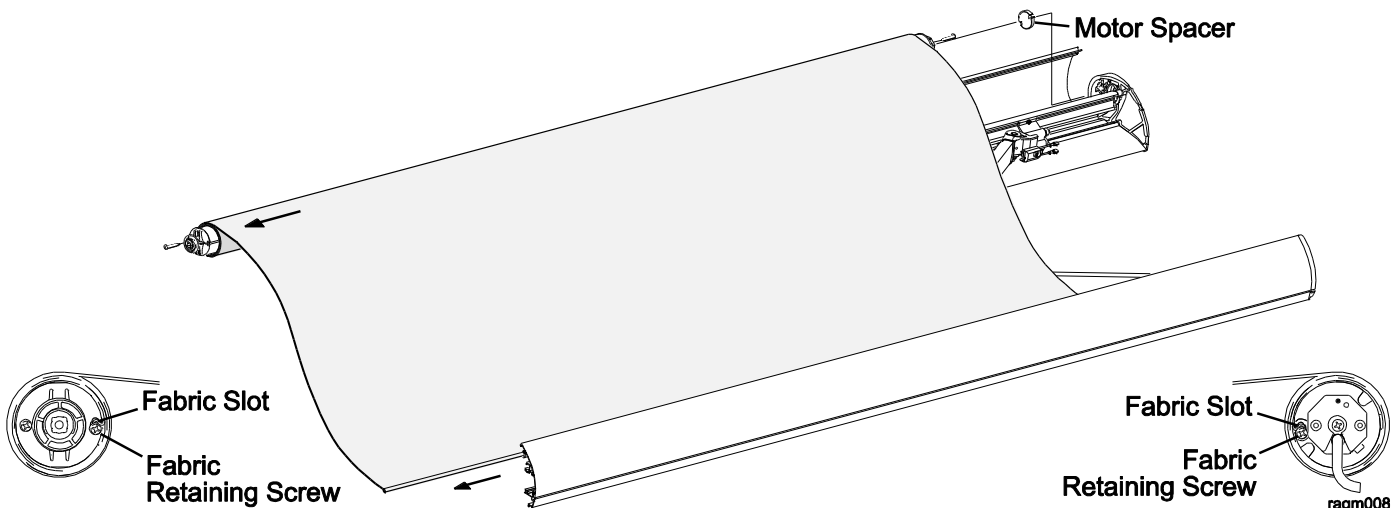
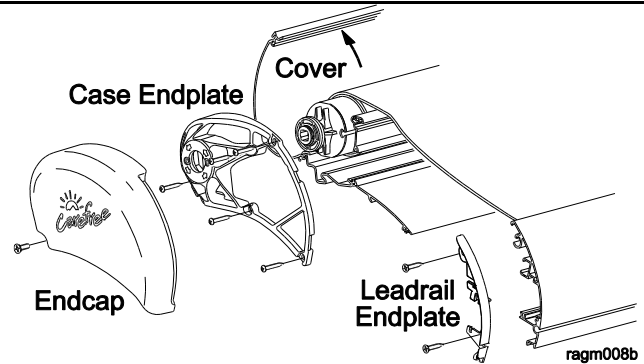

8. Lift the roller tube, fabric and motor up and out of the case.
9. Remove the fabric retaining screws from the motor bearing and idler end plug.
10. Pull the roller tube out of the case while pulling the fabric from the lead rail.

11. Note the orientation of the old canopy then unwrap and remove from the roller tube.
12. Unfold the replacement fabric then slide the new fabric onto the roller tube until the fabric and roller tube are centered.

NOTICE While the awning fabric is fairly robust, use care not to snag the new fabric while sliding it into the roller tube and lead rail.

Tip: Lightly spraying the slots with a dry silicone lubricant will help the fabric slide into the slot without staining the material.

13. Secure the fabric on the roller tube with a retaining screw through the motor bearing.
NOTE: The screw must be positioned to thread into the metal of the roller tube slot and the edge of the canopy polycord.
14. On the idler side, pull the fabric smooth in the roller tube then secure with a retaining screw through the end plug.
15. Roll the fabric onto the roller tube leaving enough material to reach between the case and the lead rail.
16. Slide the fabric into the lead rail and the roller tube into the case.
17. Seat the motor and motor spacer into the endplate. Ensure that the motor is oriented with the limit switches pointed toward the access holes in the end plate.
18. Secure the motor to the end plate with the motor screws removed previously.
19. On the idler side, position the roller tube end plug into the end plate and attach the end plate to the case. It is not necessary to close the cover at this time.
20. Attach the motor and harness wires. Fold and tuck the wires and connectors to fit inside the end cap.

NOTICE Wire colors do not match between motor, limit switch and harness. Use the wiring diagram in controller installation instructions to ensure correct connections for the motor configuration.

21. Restore power to the awning.
22. Open and close the awning to confirm that the fabric rolls and unrolls squarely. Adjust the fabric position in the lead rail as required.
23. Attach the idler side lead rail end plate.
NOTE: The top screw of the lead rail end plates secures the fabric in the lead rail. The screw should be positioned to thread into the metal of the lead rail and the edge of the polycord.
24. Attach the fabric retaining screw into the motor side lead rail end plate.
25. Close and secure the cover. There are two screws on each end of the awning.
26. Attach the end caps.
27. After installing the canopy, it may be necessary to adjust the extend limit switch. Refer to "Adjusting the Motor Limits" on page 2.

OUTER SPRING ARM REPLACEMENT

CAUTION The spring arm is under tension to open. Use extreme care to firmly hold the spring arms during assembly and disassembly to avoid any sudden or unexpected movement by the arm. Failure to follow these directions can result in serious personal injury and/or property damage.

NOTE: On replacement arms, the connector assemblies are not included and must be ordered separately if the parts are to be replaced.

The following procedure requires two people.

1. Open the awning to the maximum extension or as wide as possible. This will minimize the spring tension in the arms during this procedure.
2. Disconnect power to the awning.
3. For arms on the motor side of the lead rail:
 - 3.1. If installed, disconnect the LED connectors.
 - 3.2. Remove the LED strip wires from the endplate and allow to hang down below the lead rail
 - 3.3. Carefully remove the LED cable from the wire channel on top of the arm. Use care to not bend, break or compromise the cable. Allow the cable to hang down the side of the vehicle.
 - 3.4. Remove the two screws holding the motion sensor. Set sensor and screws aside.
 - 3.5. Detach the extend limit switch from the knuckle and set out of the way.

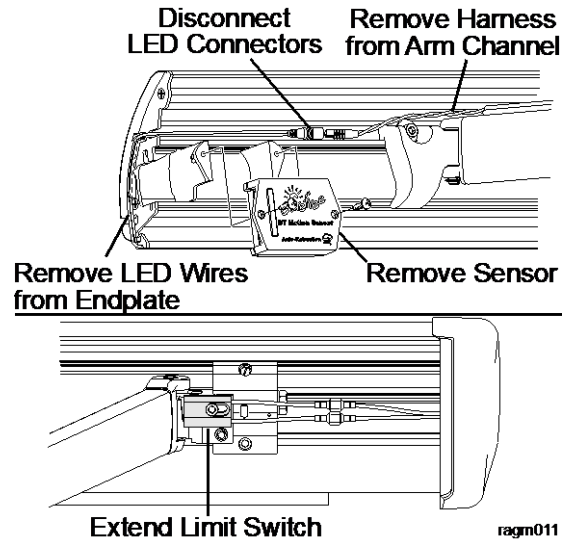

NOTICE It will be necessary to provide support for the unattached arm and lead rail when the arm is disconnected from the lead rail.

4. Remove the endplate from the lead rail.
5. For arms on the motor side, slide the sensor bracket out of the lead rail.
6. On the lead rail, mark the location of the lead rail connector.
7. Loosen the securing screw in the lead rail connector.
8. While firmly holding the arm, slide the arm and connector from the lead rail. Allow the arm to extend to its maximum length below the lead rail. Support the unattached end of the arm.
9. In the case, loosen the large screws on the side of the knuckle housing until the arm is free. Save the screws and washers.

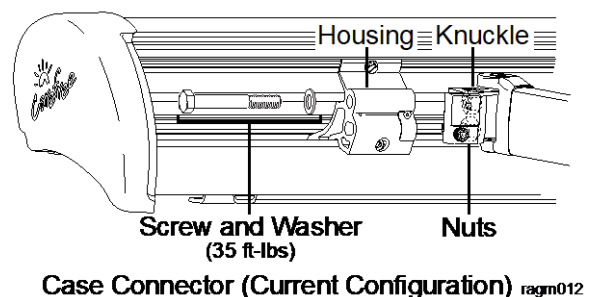
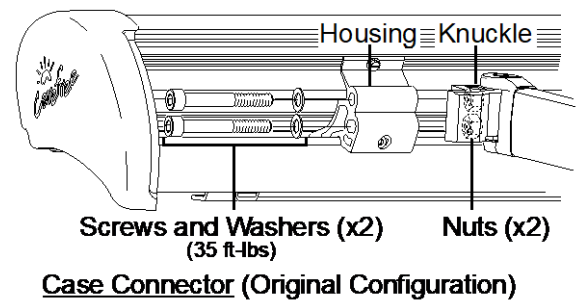
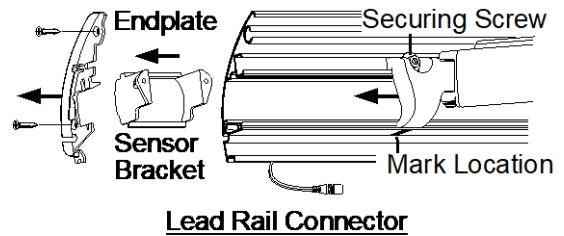

10. Remove the arm and set on a work surface.

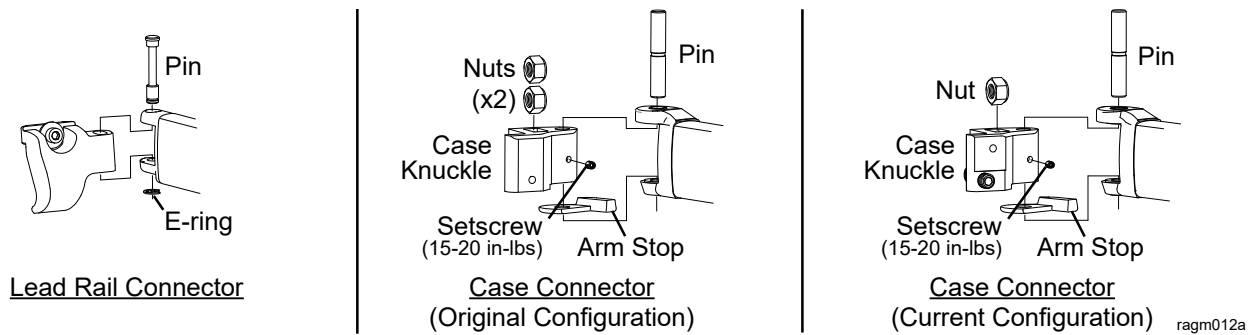

11. On a work surface, remove the lead rail connector and the case knuckle from the old arm.
12. Install the lead rail connector onto the new arm.
13. Install the case knuckle onto the new arm. Ensure that the arm stop is positioned as shown. Secure the pin with the M5 setscrew, torque to 15-20 in-lbs.
14. If the LED cable is routed on the replacement arm: Attach a piece of wire channel to the top of each section of the arm using double sided tape. If using new channel, cut each piece slightly shorter than the arm extrusion.
15. Firmly hold the new arm closed, remove the shipping ties or wrap. Allow the arm to partially open approximately 6"-8" and temporarily tie the arm in that position.
16. Lift the arm up and slide the arm and lead rail connector into the lead rail to the mark made previously.
17. Tighten the securing screw. Torque to 50-60 in-lbs.
18. While firmly holding the arm, remove the temporary ties and allow the arm to extend.
19. Position the case knuckle and secure to the knuckle housing using the M10 x75mm bolts and washers that was removed previously. Torque screws to 35 ft-lbs.
20. For the idler side arms, attach the lead rail endplate then go to step 22.
21. For the motor side arms:
 - 21.1. Attach the extend limit switch assembly to the case knuckle.

NOTE: It may be necessary to adjust the extend limit switch after installation. Refer to page 2.
 - 21.2. At the lead rail, slide the sensor mounting bracket into the lead rail. Attach the motion sensor to the bracket. Attaching the sensor to the bracket will secure the bracket in the lead rail.
 - 21.3. Attach the lead rail endplate. Torque screws to 25-30 in-lbs.
 - 21.4. Route the LED cable through the wire channel. At the arm joints, arch the cable slightly to avoid binding. Do not twist the cable.

Tip: Use a small tool, such as a flat bladed screwdriver to gently spread open the channel then insert the cable. Do this for the entire length of the channel until the cable is fully inserted.
 - 21.5. Route the LED lead wires in the endplate and into the lead rail and attach the connectors. The wires and connectors should be tucked into the channel of the lead rail.
22. After replacing the arm, it will be necessary to adjust the pitch to align the lead rail and case. See page 1.

MOTOR REPLACEMENT

PRELIMINARY STEPS (ALL CONFIGURATIONS)

1. Disconnect power to the awning.
2. If the awning is extended: Carefully push the lead rail toward the case so that the arms collapse. While holding the lead rail in this position, firmly tie the elbows of the spring arms together. Use a minimum 1/2" rope - do not use bungee cords. When tying the rope, use a non-slip knot such as a square knot or equivalent.
3. If the awning is closed: Firmly brace the lead rail in the closed position. A second person can hold the lead rail steady during the disassembly process.

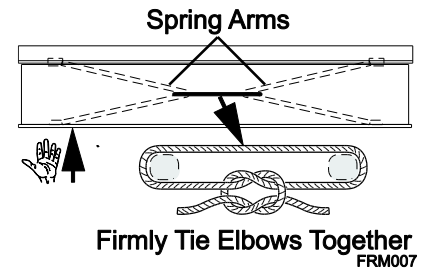

CAUTION If the awning is closed when the motor and end cap screws are removed, the spring arms will try to extend out possibly causing personal injury and damage to the awning. Support the roller tube and allow the awning to open slowly then secure the arms by tying the elbows together as described above.

CAUTION Failure to secure the lead rail as described will allow the spring arms to unexpectedly extend out possibly causing personal injury and damage to the awning.

REPLACING THE MOTOR (RIGHT ANGLE GEAR)

1. Remove the motor end cap and set aside.
2. Disconnect the motor wires from the harness.
3. Remove the motor screws (x2) and the endplate screws (x5) and set aside.
4. Pull the endplate away from the case.
5. Pull the old motor out of the roller tube and set aside.
6. Place the one-way drive onto the new motor.
 - 6.1. For RH motors the "B" points toward the motor.
 - 6.2. For LH motors the "A" points toward the motor.
 - 6.3. Secure with the new clip.

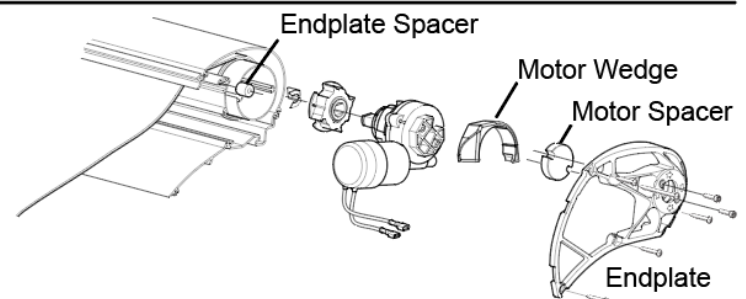
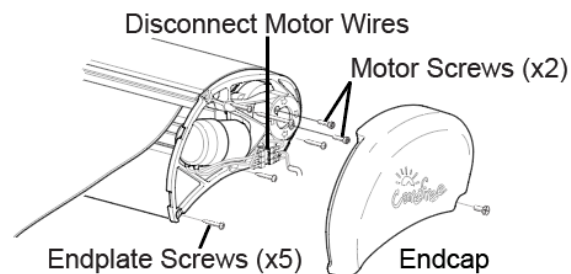

NOTICE If the drive is not oriented correctly, the awning will not operate and the arms will spring out when released.

7. Align the one-way drive with the roller tube and start sliding the new motor into the roller tube.
8. Align the bearing on the motor and slide into the roller tube.

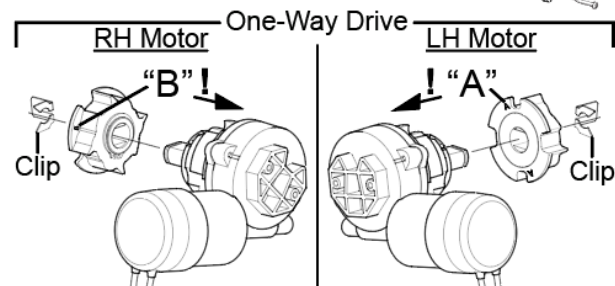

9. Insert either Left Hand or Right Hand Motor Wedge onto the Left Hand motor or the Right Hand motor
10. Attach the end plate to the motor with the motor screws removed previously.
11. Align the screw holes in the end plate and attach to the awning case.
12. Attach the motor wires. Fold and tuck the wires and connectors to fit inside the end cap.

ragm015

NOTICE Wire colors do not match between motor, limit switch and harness. Use the wiring diagram in controller installation instructions to ensure correct connections for the motor configuration.

13. While holding the lead rail, carefully remove any roller tube supports and arm ties. Allow the lead rail to extend until the fabric is taut. If the lead rail continues to extend after the fabric is taut, the one way drive was installed backwards. Tie the arms, remove the motor and orient the one way drive as shown.
14. Attach the end cap.

REPLACING THE MOTOR (TUBULAR)

Refer to "Preliminary Steps" on page 11 before beginning this procedure.

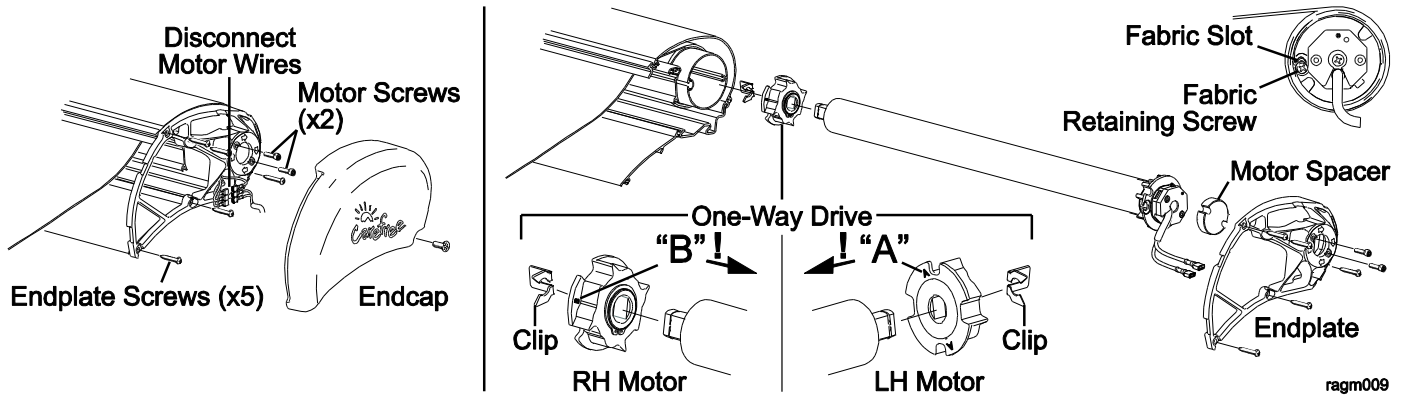

1. Remove the motor end cap and set aside.
 2. Disconnect the motor wires from the harness.
 3. Remove the motor screws (x2) and the endplate screws (5) and set aside.
 4. Pull the endplate away from the case.
 5. Remove the fabric retaining screw from the motor bearing.
 6. Pull the old motor out of the roller tube and set aside.
 7. Place the one-way drive onto the new motor.
 - 7.1. For RH motors the "B" points toward the motor.
 - 7.2. For LH motors the "A" points toward the motor.
 - 7.3. Secure with the new clip.
- NOTICE** If the drive is not oriented correctly, the awning will not operate and the arms will spring out when released.
8. Align the one-way drive with the roller tube and start sliding the new motor into the roller tube.
 9. Align the bearing on the motor and slide into the roller tube.
 10. Attach the fabric retaining screw through the bearing and into the fabric slot. The screw must be positioned to thread into the metal of the roller tube slot and the edge of the canopy polycord.
 11. Insert the motor spacer into the endplate.
 12. Attach the endplate to the motor with the motor screws removed previously. Ensure that the motor is oriented with the limit switches pointed toward the access holes in the end plate.
 13. Align the screw holes in the end plate and attach to the awning case.
 14. Attach the motor wires. Fold and tuck the wires and connectors to fit inside the end cap.
- NOTICE** Wire colors do not match between motor, limit switch and harness. Use the wiring diagram in controller installation instructions to ensure correct connections for the motor configuration.
15. While holding the lead rail, carefully remove any roller tube supports and arm ties. Allow the lead rail to extend until the fabric is taut. If the lead rail continues to extend after the fabric is taut, the one way drive was installed backwards. Retie the arms, remove the motor and orient the one way drive as shown.
 16. To test:
 - 16.1. Restore power.
 - 16.2. Use the switch to extend and retract the awning.
 17. After replacing the motor, it may be necessary to adjust the motor limit switches (page 1).
 18. After testing and adjusting the motor limit switches, attach the end cap.

BT12 SYSTEM

The BT12 Wireless Awning Control System offers multiple methods of operating the awning, including standard switch operation, the Carefree Connects Mobile App, and the BT Remote. Please refer to the installation instructions for any questions about the wiring or operations of the BT12 system.

DRC12 SYSTEM

The DRC12 Wireless Awning Control System offers multiple methods of operating the awning, including standard switch operation, the Carefree Connects Mobile App. Please refer to the installation instructions for any questions about the wiring or operations of the DRC12 system.

PART NUMBER LISTING

PART NUMBER/SERIAL NUMBER LOCATION

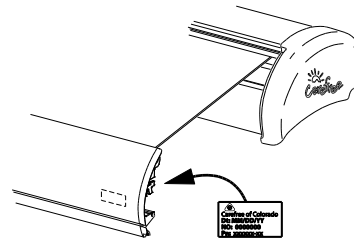

Serial# / Part# Located Inside the Lead Rail on the Motor Side
ragm014

ILLUSTRATED PARTS LIST

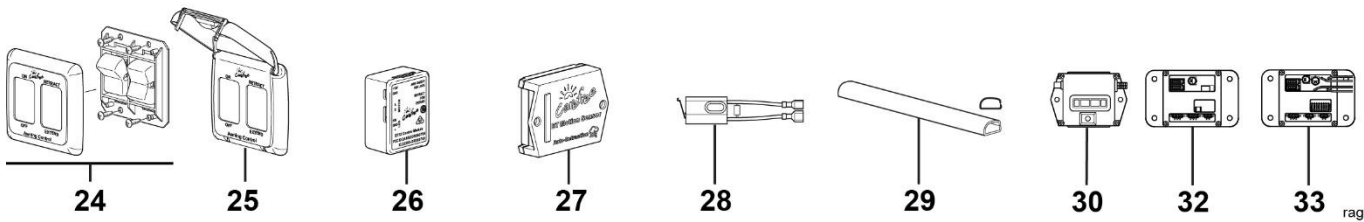
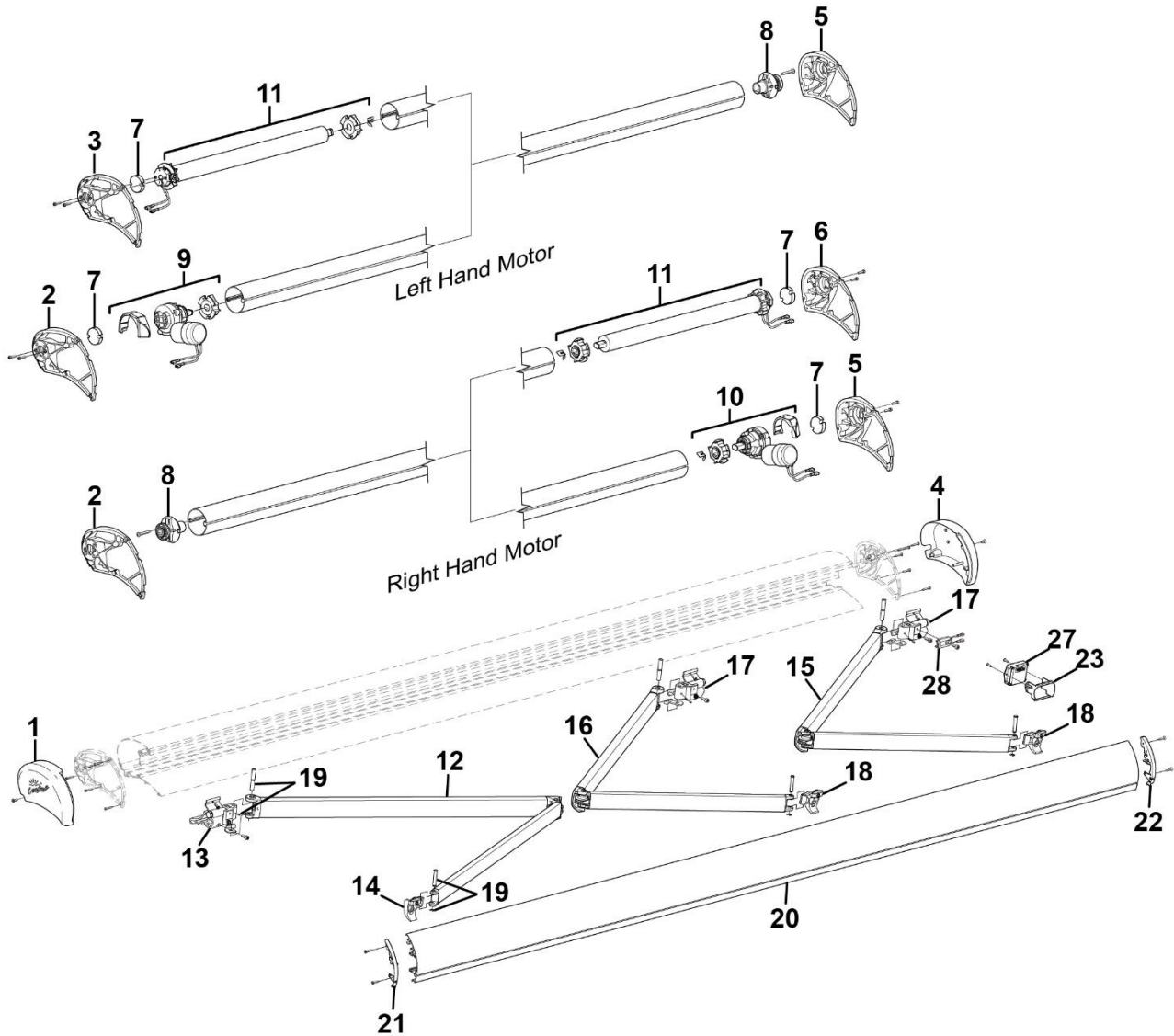

ragm501

Item	Part Number	Description	Notes
1	R037563-001-JV	Endcap, LH	Black
	R037563-001-25	Endcap, LH	White
2	R037562-001	Case Endplate, LH	used with idler or LH right angle motor
3	R037562-001-T	Case Endplate, LH	used with tubular motor
4	R037563-002-JV	Endcap, RH	Black
	R037563-002-25	Endcap, RH	White
5	R037562-002	Case Endplate, RH	used with idler or RH right angle motor
6	R037562-002-T	Case Endplate, RH	used with tubular motor
7	R041603-001	Spacer, Motor	
8	R001623	End Plug	
9	R002012	Motor Assembly, Right Angle, LH	
10	R002011	Motor Assembly, Right Angle, RH	3
11	R002010	Motor Assembly, Tubular	
12a	R012530-TB68L	Spring Arm, LH	2.44 Meter 2
12b	R012530-TB79L	Spring Arm, LH	2.57 Meter 2
12c	R012530-TB94L	Spring Arm, LH	3 Meter & Up 2
13	R019916-001	Connector Assy, Case, LH	
14	R001629	Connector Assy, Lead Rail, LH	
15a	R012530-TB68R	Spring Arm, RH	2.44 Meter 2
15b	R012530-TB79R	Spring Arm, RH	2.57 Meter 2
15c	R012530-TB94R	Spring Arm, RH	3 Meter & Up 2,5
16	R012530-TB94M	Spring Arm, Center	4.5 and 5 Meter 2,5
17	R019916-002	Connector Assy, Case, RH	
18	R001628	Connector Assy, Lead Rail, RH	
19	R001595	Hardware Pack, Arm Attach, 1 Arm	
20	R002017XX-()-xxx	Lead Rail	4
21	R041555-001-JV	Lead Rail End Plate, LH	Black
	R041555-001-25	Lead Rail End Plate, LH	White
22	R041555-002-JV	Lead Rail End Plate, RH	Black
	R041555-002-25	Lead Rail End Plate, RH	White
23	R001679	Sensor Bracket Kit	
24	R019468-006	Switch Kit	
25	SR0115	Covered Bezel Kit	Optional
26	R060780-001	BT12 Control Module	
27	R060808-001	BT Motion Sensor	
28	R001991-001	Extend Limit Switch Kit	LH
	R001991-002	Extend Limit Switch Kit	RH
29	R040616-206	Wire channel, 43" taped	
30	R002030	DRCMOLED Module	
31	R002031	DRCMOLED Module with Cable (not shown)	
32	R002039	DRCHUB Module	
33	R002040	DRC12 Module	

- Notes:
1. XXX = Color: 001 = Mill; 005 = White; 006 = Black; 231 = Satin; 0JP = Tan; 0JQ = Taupe; 0JR1 = MBWh; 0JS1 = MBBk; 0JU1 = MBSil
 2. Attaching hardware not included with arm assemblies. Order item 19.
 3. Motor assemblies (items 9, 10, 11) include motor, bearing and one-way drive. Components not available separately.
 4. For Item 20 (lead rail): XX= Color; () = LED application: l= w/ LED inside, X=No LED; xxx= product order length.
 5. The middle spring arm is different than the outer arms. Center arms can be identified by the blue dot located on or near the case connector of the arm. Do not use center arms for replacing outer arms, do not use outer arm to replace the center arm.

For LED replacement parts and service procedures refer to 070013-301 "LED Service Manual for Box Awnings" available on-line at www.carefreeofcolorado.com

FREESTYLE RM BRACKET KITS

Bracket kits are ordered separately. Several types are available based on the application installation. Bracket mounting instructions are separate supplements of the installation manual.

BS0012

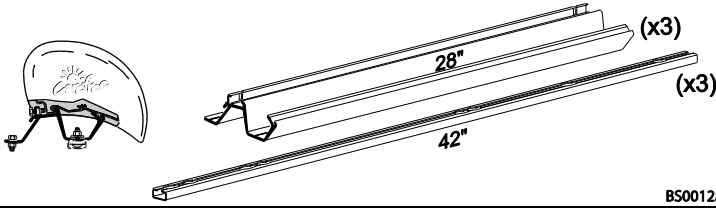

Sprinter
4.5m & 5m

Mill Finish
Bracket and Awning Hardware included
Instruction Supplement: 052570-012

BS0013

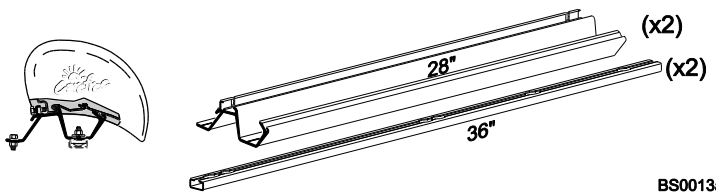

Sprinter
4m and less

Mill Finish
Bracket and Awning Hardware included
Instruction Supplement: 052570-013

BS0014

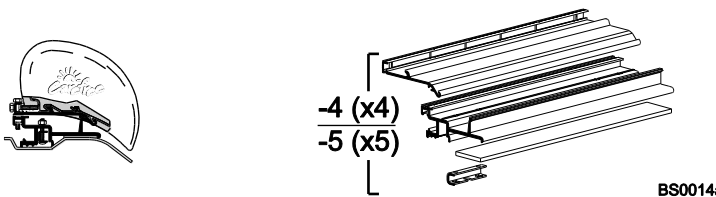

Dodge ProMaster; Fiat Ducato

(-4) 4 Brackets 3.5m
(-5) 5 Brackets 4m

Mill Finish
Bracket and Awning Hardware included
Instruction Supplement: 052570-014

BS0016

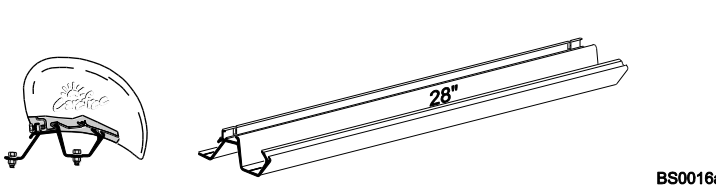

Flat Roof

(-3) 3 Brackets 4m
(-4) 4 Brackets 4.5m & 5m

Mill Finish
Bracket and Awning Hardware included
Instruction Supplement: 052570-016

BS0017

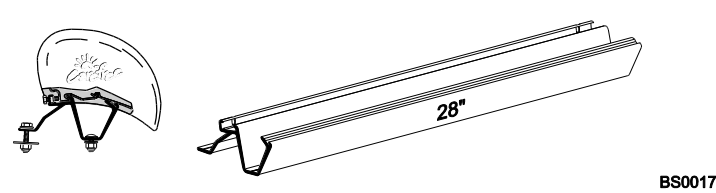

Sprinter – No Rail

(-28-2) 2 Brackets up to 4m

Mill Finish
Bracket and Awning Hardware included
Instruction Supplement: 052570-017

FULL LENGTH BRACKETS

BS0015

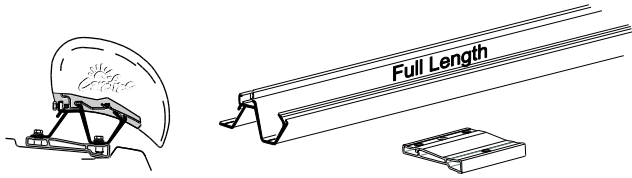

BS0015a

Ford Transit

(-118-XX) Full Length 3m
 (-138-ML) Full Length 3.5m
 (-157-XX) Full Length 4m
 Mill (ML) or Black (JV) Finish
 Bracket and Awning Hardware included
 Instruction Supplement: 052570-015

BS0018

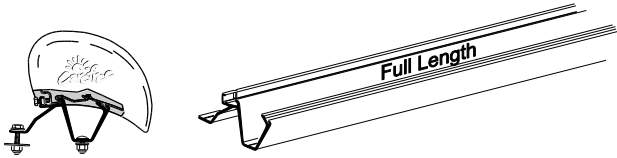

BS0018a

Sprinter – No Rail

(-118-XX) Full Length 3m
 (-157-XX) Full Length 4m
 (-177-XX) Full Length 4.5m
 Mill (ML) or Black (JV) Finish
 Bracket and Awning Hardware included
 Instruction Supplement: 052570-018

BS0019

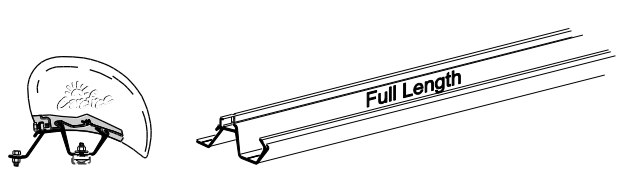

BS0019a

Sprinter used w/ OEM Rail & Flat Roof

(-118-XX) Full Length 3m
 (-157-XX) Full Length 4m
 (-177-XX) Full Length 4.5m
 (-197-XX) Full Length 5m
 Mill (ML) or Black (JV) Finish
 Bracket and Awning Hardware included
 Instruction Supplement: 052570-019

BS0021

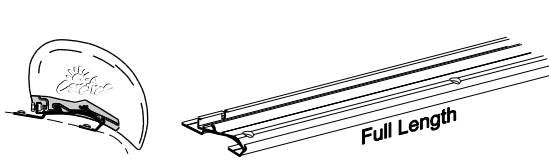

BS0021a

Low Profile RM Mounting Bracket Kit

(-157-ML) Full Length 4m
 (-177-XX) Full Length 4.5m

 Mill (ML) or Black (JV) Finish
 Bracket and Awning Hardware included
 Instruction Supplement: 052570-021

BS0023

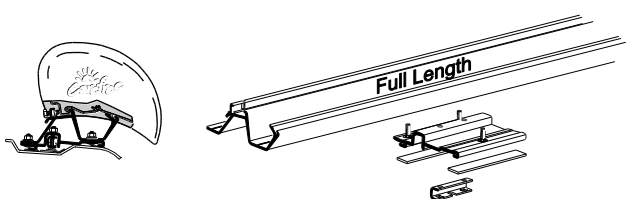

BS0023a

Dodge ProMaster

(-157-XX) Full Length 4m

 Mill (ML) or Black (JV) Finish
 Bracket and Awning Hardware included
 Instruction Supplement: 052570-023