

AFTERMARKET INSTALLATION MANUAL

COMPASS ARMS AND CANOPY

CAREFREE ARM STYLE CODE "TA"

ROLLER ASSEMBLIES:

"14,AE,AJ,AK,AL,AM,AN,CK,CW,CX,

CZ,DS,DZ,EC,ED,EH,EI,EJ,EK,EL,EM,EN,FL,FM,

FY,GY,GZ,HM,HW,HX,IL,IM,IU,IV,IY,IZ,JB,JJ,KK,KL,

KP,KQ,OS,OT,OU,QL,QJ,QK, QZ,TO,TQ,TU,TY,TZ,UT"



RV

12V MOTORIZED AWNING WITH ADJUSTABLE PITCH



Read this manual before installing or using this product. Failure to follow the instructions and safety precautions in this manual can result in personal injury and/or cause the product to not operate properly.



TABLE OF CONTENTS

Product Overview	1
Specifications:	1
Component Checklist.....	2
Required Pre-Installation Preparation	3
Upgrades to Existing Awnings	3
Upgrades for a Manual Awning.....	3
Upgrades for a Motorized Awning.....	3
Installing an Awning Rail.....	4
Roller Tube Endcaps	4
Top Mounting Brackets.....	4
Installation	5
Attaching the Roller Tube	5
Cable Routing at the Top of the Arm.....	5
Routing LED Harness to Bottom of the Arm.....	5
Mounting the Awning	6
Mounting the Arms	6
Securing the Fabric.....	7
Wire Routing	8

Control System	9
Optional LED's.....	11
Switch Installation for LED's.....	11
Optional Wire Covers.....	12

PROPRIETARY STATEMENT

The Compass Awning is a product of Carefree of Colorado, located in Broomfield, Colorado, USA. The information contained in or disclosed in this document is considered proprietary to Carefree of Colorado. Every effort has been made to ensure that the information presented in the document is accurate and complete. However, Carefree of Colorado assumes no liability for errors or for any damages that result from the use of this document.

The information contained in this manual pertains to the current configuration of the models listed on the title page. Earlier model configurations may differ from the information given. Carefree of Colorado reserves the right to cancel, change, alter or add any parts and assemblies, described in this manual, without prior notice.

Carefree of Colorado agrees to allow the reproduction of this document for use with Carefree of Colorado products only. Any other reproduction or translation of this document in whole or part is strictly prohibited without prior written approval from Carefree of Colorado.

SAFETY INFORMATION



This is the safety alert symbol. It is used to alert individuals to potential personal injury hazards. Obey all safety messages that follow this symbol to avoid possible personal injury or death.



Indicates a hazardous situation, which if not avoided, could result in death or serious bodily injury.



Indicates a hazardous situation, which if not avoided, may result in minor or moderate bodily injury.



Indicates a situation that may result in equipment-related damage.

General Safety:



This product can expose you to chemicals including Di-isodecyl phthalate (DIDP), Vinyl Chloride and Formaldehyde, which are known to the state of California to cause cancer or birth defects or other reproductive harm. For more information visit www.P65warnings.ca.gov



Shock Hazard. Always disconnect battery or power source before working on or around the electrical system.



Always wear appropriate safety equipment (i.e. goggles).



Always use appropriate lifting devices and/or helpers when lifting or holding heavy objects.



When using fasteners, do not over tighten. Soft materials such as fiberglass and aluminum can be "stripped out" and lose the ability to grip and hold.

PRODUCT OVERVIEW

The adjustable pitch Compass provides motorized awning comfort with Carefree's standards for looks, strength and dependability with a successful blend of style, quality and economy.

The variable pitch offers 6 settings from flat (3°) to steep (16°).

The awning roller tube and arms are made from light weight, no-rust aluminum. The awning fabric is heavy weight vinyl.

White and RGB LED lighting is available with the strip mounted in the roller tube or at the awning rail.

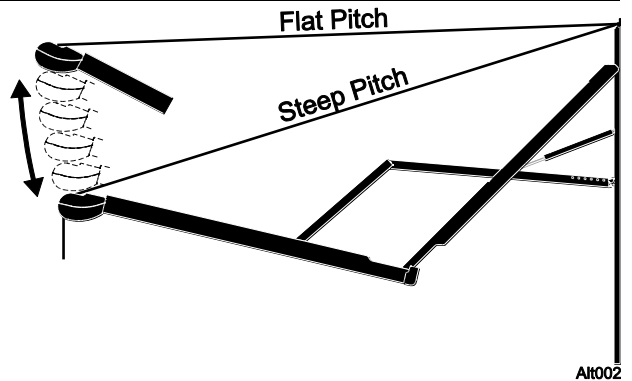

Specifications:

MAXIMUM EXTENSION:		90 inches	MAXIMUM LENGTH:		20 feet
PITCH:	FLAT	3°	DROP:	approximately 6 inches	
	STEEP	16°		approximately 26.5 inches	
Angle is Canopy vs horizontal			Measurement is from centerline of Awning Rail to centerline of roller tube		
MOTOR:		Power: 10VDC–14VDC	Circuit Rating: 15 amp		motor mounted in arm
POWER SOURCE:		Motor and controls are routed and hardwired into the vehicle's 12V system			
EXTEND ACTUATION:		Gas Shock			
POSITION CONTROL:		Motorized roll out/in			
CONTROLLER:		SC12 Awning Control System			
COLOR:	Frame:	White, Black			
	Canopy:	Vinyl with vinyl Weatherguard or FLXguard. Refer to sales literature for options.			
LED	LED strip mounted in roller tube				
	Power:	1A, 12VDC			
	Control	Single pole, single throw switch (SR0101) <i>Note: The Switch kit is ordered separately. Kit includes in-line fuse holder and 2A spade type fuse. For an installer furnished control switch, see note under "Switch Installation".</i>			

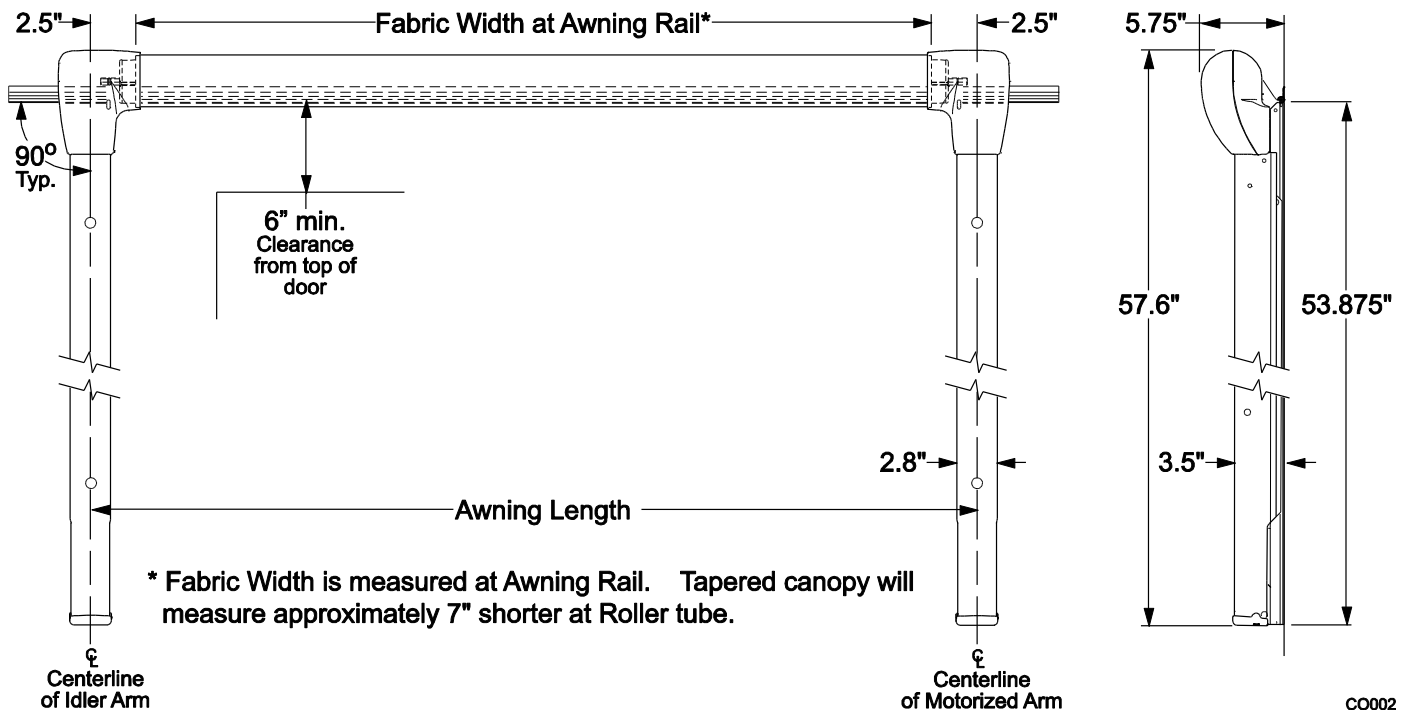

COMPONENT CHECKLIST

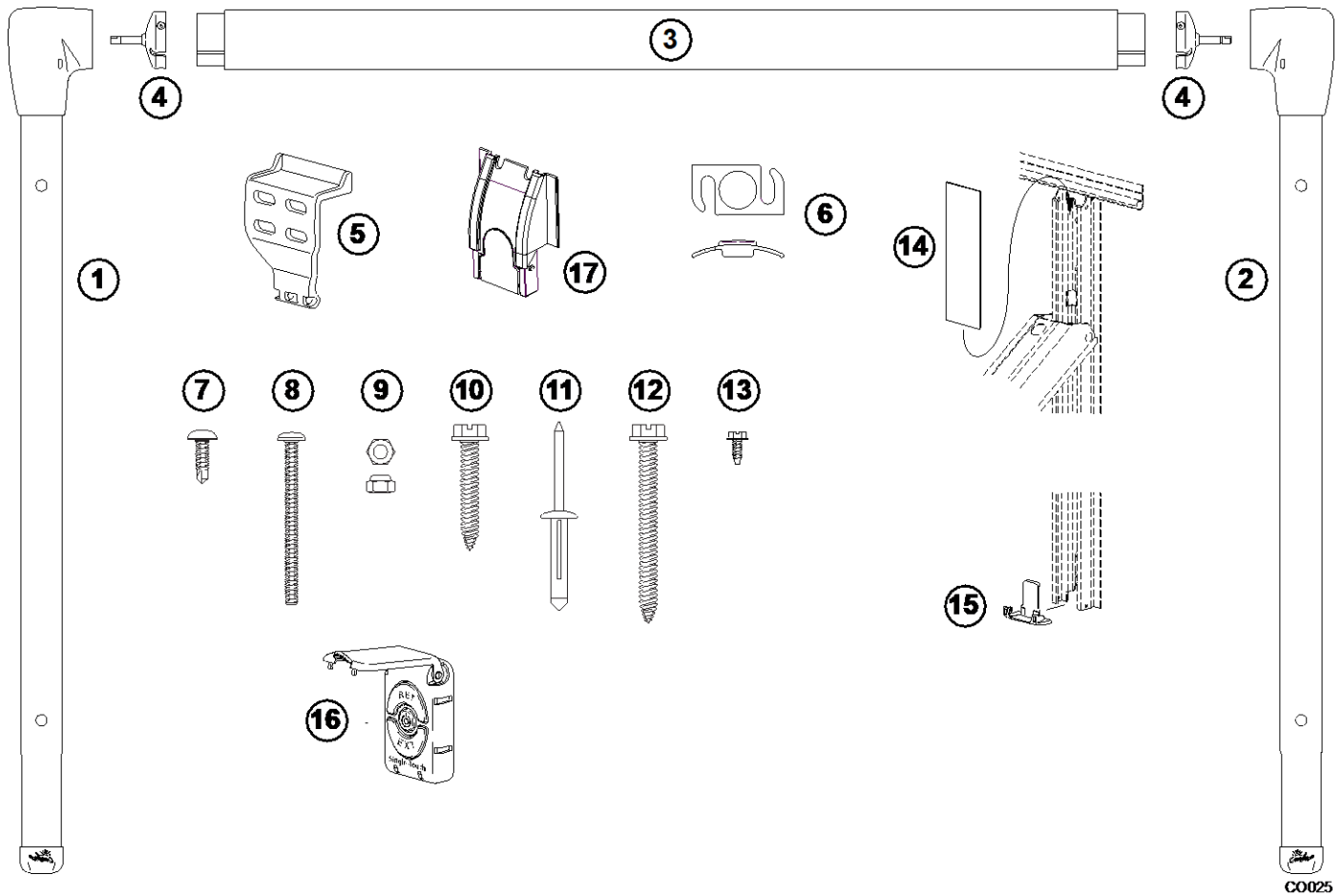

C0025

QTY	ITEM	DESCRIPTION	QTY	NOTE
<input type="checkbox"/>	1	Arm Assembly, LH	1	1
<input type="checkbox"/>	2	Arm Assembly, RH	1	1
<input type="checkbox"/>	3	Roller tube Assembly	1	Ordered Separately 1
<input type="checkbox"/>	4	Endcap, Roller Tube	2	
<input type="checkbox"/>	5	Top Bracket	2	
<input type="checkbox"/>	6	Hole Plug	4	
<input type="checkbox"/>	7	Screw, Truss Head	6	endcap attach #10 x 5/8
<input type="checkbox"/>	8	Screw, Phillips	2	top bracket attach #10 x 2 1/4
<input type="checkbox"/>	9	Nut, Nylock	2	top bracket attach #10
<input type="checkbox"/>	10	Screw, Lag	12	arm attach #14 x 1 1/2
<input type="checkbox"/>	11	Moly Rivet	8	arm attach – alternate 3/16
<input type="checkbox"/>	12	Screw, Lag	4	arm attach – top #14 x 2 1/2
<input type="checkbox"/>	13	Screw, Hex Washer Head	2	canopy #6 x 3/8
<input type="checkbox"/>	14	Wire Cover, Upper, Optional	1	2
<input type="checkbox"/>	15	Wire Cover, Lower, Optional	1	2
<input type="checkbox"/>	16	SC12 Switch	1	
<input type="checkbox"/>	17	Longitude Replacement Spacer	2	3

Notes: 1. Awning configuration is specified at time of order, including awning length, fabric, color etc. Check awning assembly against original purchase order. Arms are configuration specific and are not interchangeable.
 2. Wire Covers (15, 16) are optional and must be specified at time of order.
 3. Longitude Replacement spacer allows installation in same vertical location as Longitude armsets

REQUIRED PRE-INSTALLATION PREPARATION

1. Park the vehicle on a flat surface and level the unit.
2. Check where the awning arms will be installed. The arms fit snug to the side of the vehicle and must not cover or interfere with exhaust vents, lights etc.
3. If there is an awning rail installed, check that the awning rail runs the full length of the awning. Please refer to the note under "Installing an Awning Rail" before proceeding.

UPGRADES TO EXISTING AWNINGS

NOTICE If the existing awning canopy has a metal wrap (Uniguard, Alumaguard), it will be necessary to replace the existing canopy with a new canopy that has FLXguard or vinyl weatherguard.

1. Carefully mark the centerline location of the existing arms.
2. Extend the awning per the awning manufacturer's instructions.
3. Remove the canopy retaining screws in the awning rail.
4. For motorized awnings, disconnect power to the awning.

Upgrades for a Manual Awning

Manual awnings contain springs in the roller tube. Follow the manufacturer's service procedures to safely remove the springs.

CAUTION This procedure requires working with the roller tube springs. When removed from the arm, the spring is under extreme tension and will unwind quickly. Keep hands and clothing clear! Do not try to hold the end plug by hand, use vice grips or similar tools. Failure to follow the instructions can result in personal injury and property damage.

1. On one arm, remove the end plug, endcap and spring from the arm.
 - 1.1. It will be necessary to hold the arm and move it out of the way when the end plug is removed.
 - 1.2. It will be necessary to support the roller tube until the other side is disconnected.
2. Repeat for other side.
3. Allow the roller tube and canopy to hang down the side of the vehicle.
4. Remove the arms from the vehicle.
5. Remove any existing brackets.
6. Remove the springs, end plugs and endcaps from the roller tube.
7. Plug and seal all mounting holes. The mounting holes of the new arms may not match the old awning arms.

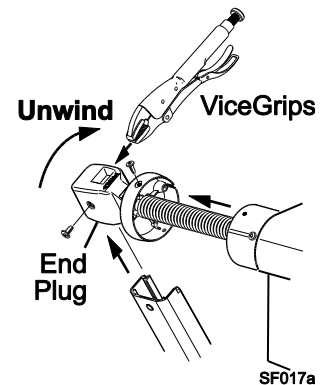

Upgrades for a Motorized Awning

1. Determine the existing wiring configuration:
 1. If the existing installation uses an external wall plug, the installer must furnish the mating plug for the new motor wires or remove the wall connector and wires. Plug and seal the hole then follow the standard wiring instructions.
2. Disconnect the existing motor wires. Remove the existing switch and any control box electronics.
2. On one arm, disconnect the roller tube from the arm.
 - 2.1. The arm will extend out when the roller tube is disconnected.
 - 2.2. It will be necessary to support or hold the roller tube until the other side is disconnected.
3. Repeat for other side.
4. Allow the roller tube and canopy to hang down the side of the vehicle.
5. Remove the arms from the vehicle.
6. Remove any existing brackets.
7. Plug and seal all mounting holes. The mounting holes of the new arms may not match the old awning arms.

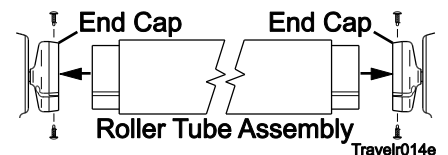

INSTALLING AN AWNING RAIL

NOTE: If the vehicle already has a full-length awning rail installed, skip to step 5. The awning rail and arms must be positioned so that any existing trim does not interfere with the awning arm when in the closed position.

1. Determine the optimum positioning of the awning so that the arms will not interfere with the door frame or light fixtures. The centerline of the awning rail should be above the door opening a minimum of 6". After determining mounting position, mark the position with a chalk line.
2. Awning rail must be level.
3. Seal the back of the rail with silicone sealant or putty tape.
4. Align the awning rail onto the wall and secure with #10 x 3/4" screws. Use all the attach holes in the rail.

NOTICE Make sure the screws are securely mounted to the structural frame of the vehicle.

5. Use a screwdriver to spread open one end of the awning rail on the installation side.
6. File any sharp edges or burrs from the end of the rail. This will help protect the awning fabric from damage during installation.
7. Spray inside the awning rail track with a dry silicone lubricant.

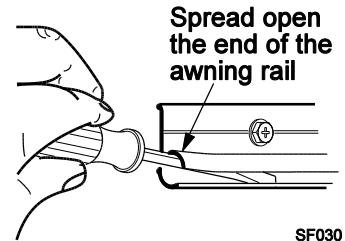

SF030

ROLLER TUBE ENDCAPS

NOTE: If current roller is a Carefree shaft driven roller, then skip this step.

3. Press the endcaps onto the ends of the roller tube.
 - 1.1. The slots in the endcaps must line up with the slots in the roller tube
4. The cap must be fully inserted onto the roller tube. The endcap must seat squarely over the end of the roller tube.
2. Attach each endcap with three (3) #10 x 5/8 truss head screws.

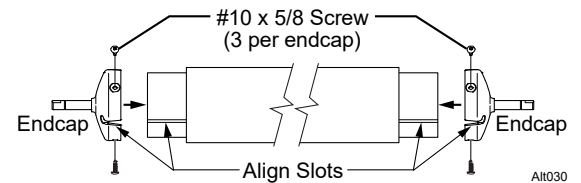
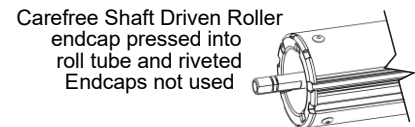

Alt030

TOP MOUNTING BRACKETS

On each arm attach the top mounting bracket to the channel using one (1) #10 x 2 1/4 screw and nylock nut.

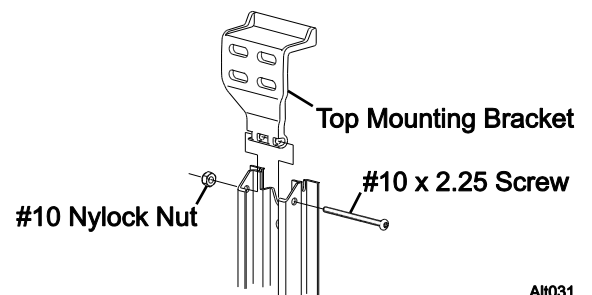

Alt031

INSTALLATION

ATTACHING THE ROLLER TUBE

FOR AWNING UPGRADES WITH THE CANOPY ALREADY INSTALLED ON THE VEHICLE, start at "Mounting the Arms" on page 6.

- On the RH (motor) arm, press the roller tube shaft into the hole in the motor head. It may be necessary to twist the roller tube to align the flats on the roller tube shaft with the flats in the motor head bearing.

NOTE: The retaining clips are factory installed in the rear head cover as shown.

- Press the retaining clip in until it is firmly seated in the groove of the shaft. It may be necessary to shift the roller tube shaft until the clip aligns with the groove of the shaft.

NOTICE The roller tube must be fully inserted into the head for the clip to align with the groove on the shaft. The roller tube can disengage if the clip does not seat in the groove of the shaft.

- On the LH (idler) arm, press the roller tube shaft into the hole in the idler head.
- Press the retaining clip in until it is firmly seated in the groove of the shaft. It may be necessary to shift the roller tube shaft until the clip aligns with the groove of the shaft.

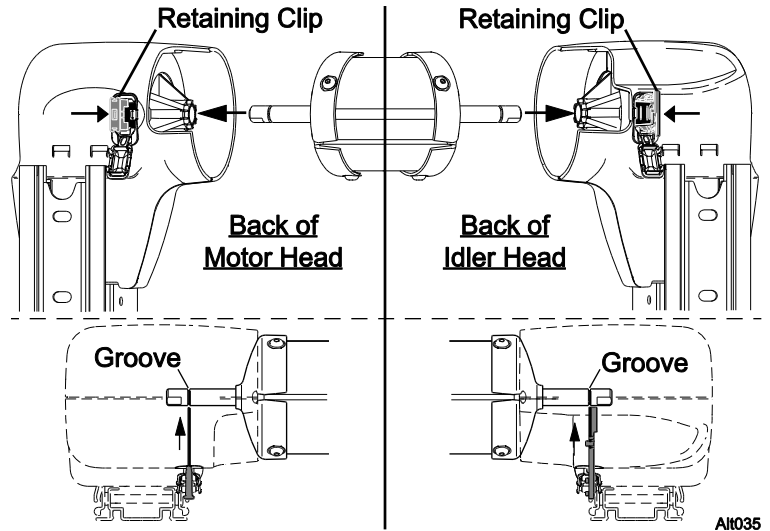

- Decide on the location of the switches to determine the cable routing.

Cable Routing at the Top of the Arm

- Remove the cable tie at the top of the motorized arm. Partially open the arm being careful to not let the arm extend more than 6".

CAUTION The arm is under tension from the gas shock located in the arm.

- Pull the cables from the back of channel and out the pass-thru hole in the top of the channel.
- Close the arm.
- Secure the top of the arm in the closed position using a plastic wrap or equivalent.

Routing LED Harness to Bottom of the Arm

- Leave Motor Cable in arm channel.
- Route the LED harness through the routing slot on the side of the arm and down the rear channel.

NOTE: Allow enough slack to create a 3" loop between the canopy and rail.

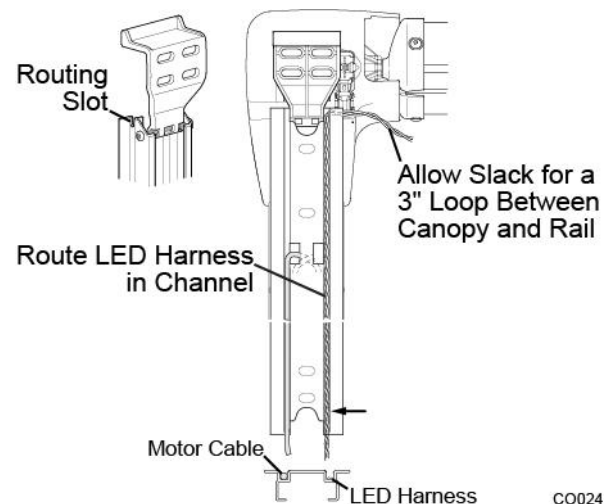

MOUNTING THE AWNING

NOTICE It is recommended that at least three people install the awning due to its size and weight.

1. On the awning rail, mark the location of the centerline of the idler and motor arm assemblies.

FOR AWNING UPGRADES WITH THE CANOPY ALREADY INSTALLED ON THE VEHICLE, go to step 4 “Mounting the Arms”.

2. Unroll the canopy one wrap.

NOTE: While the awning fabric is fairly robust, care must be taken not to snag it on the awning rail.

3. With one person holding each arm, the third person should thread the polyrod (the plastic rod on the edge of the fabric) into the awning rail. Carefully move across the vehicle, gently pulling the fabric into the rail, until the awning is in the desired location.

NOTICE During assembly and installation, the arm assemblies must remain perpendicular to the roller assembly. Failure to handle the arm assemblies carefully can bend the drive shaft.

Mounting the Arms

4. Position the motor arm on the vehicle: Align the center of the arm with the centerline marked in step 1. Butt the top of the rear channel against the awning rail as shown.
5. Hold the arm in position and drive a screw through the upper access hole (▲) and rear channel into the vehicle wall.
6. Confirm that the arm is perpendicular to the awning rail then drive a screw through the lower access hole (▲) and rear channel into the vehicle wall.
7. Hold the idler arm assembly perpendicular to the awning rail and drive a screw through the upper access hole (▲) and rear channel into the vehicle wall.
8. Confirm that the arm is perpendicular to the awning rail then drive a screw through the lower access hole (▲) and rear channel into the vehicle wall.
9. Hold the awning closed and carefully remove the cable ties at the top of the arms. The awning will open a few inches.
10. Open the awning to access the remaining mounting holes. To open:
 - 10.1. Temporarily connect the ends of the motor wires to a 12V-14V source (i.e. drill battery). If the awning does not begin to move, reverse the leads.
 - 10.2. Remove the battery.
11. Attach each arm through the top brackets using two (2) each #14 x 2 1/2" lag screws. Requires a 5/32" pilot hole.

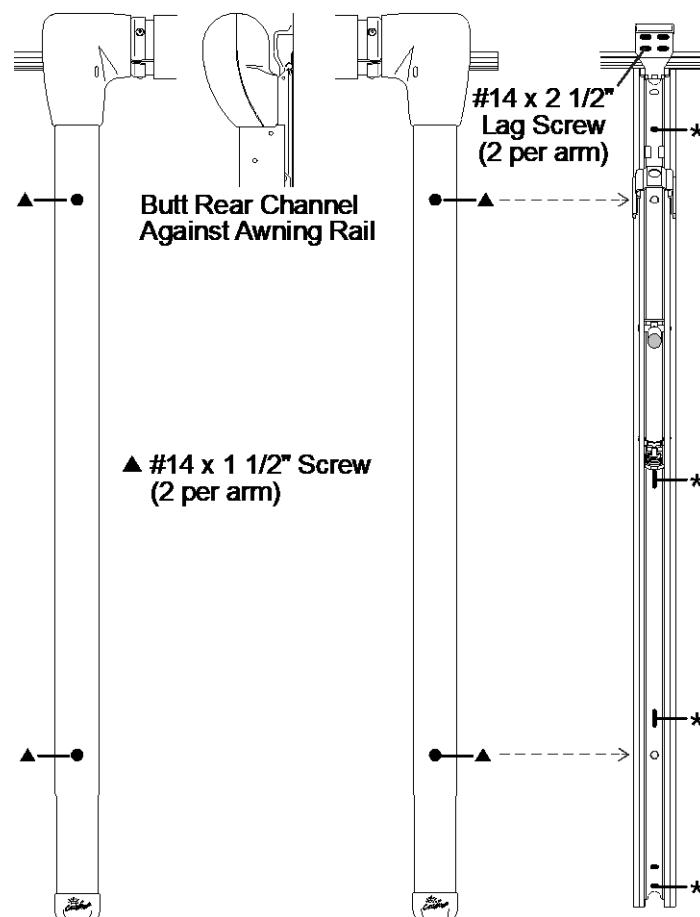

***NOTE:**
If mounting into structure: Use #14 x 1 1/2" lag screws. Requires a 5/32" pilot hole.
If mounting to the outer skin only: Use 3/16" moly rivets. Requires a 7/32" (#4) hole.

CO026

12. Attach each arm in the additional positions (marked with an *) shown (4 places per arm).

FOR AWNING UPGRADES WITH THE CANOPY ALREADY INSTALLED ON THE VEHICLE, go to “Attaching the Roller Tube” on page 5.

13. On the back of the motor and idler heads, remove the plastic retaining clip covers.
14. Rotate the access covers up and snap into the retaining clip openings.

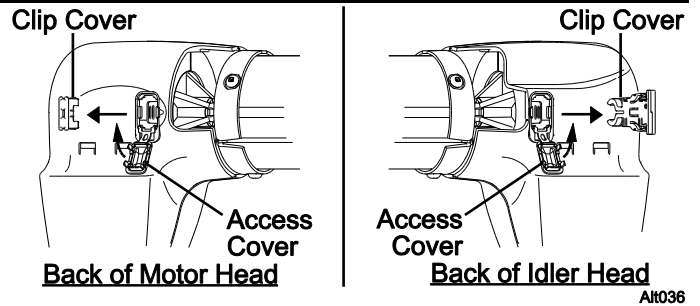

15. Install the hole plugs in the front channel:
 - 15.1. From the back of the channel, insert the plug into the hole.
 - 15.2. Twist to lock into place.

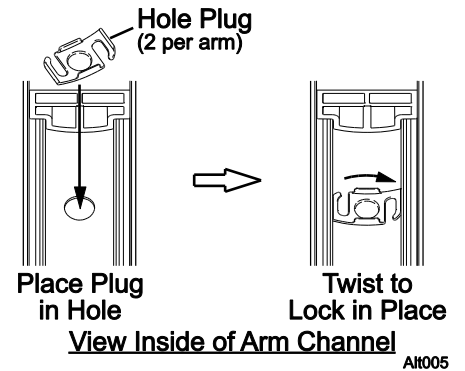

SECURING THE FABRIC

1. Roll the awning in and out several times to make sure that the fabric rolls up straight.
2. Attach the canopy in the awning rail using one #6 x 3/8" hex head screw on one side of the awning. Place screw through awning rail, fabric and polyrod approximately 1" in from the end of the fabric.
3. On the opposite side, pull the fabric tight in the awning rail place one #6 x 3/8" hex head screw on one side of the awning. Place screw through awning rail, fabric and polyrod approximately 1" in from the end of the fabric.

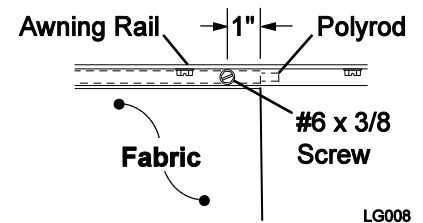

WIRE ROUTING



! WARNING Shock Hazard. Always disconnect battery or power source before working on or around the electrical system.

- Notes:**
1. Failure to follow the wiring instructions in this publication may void the motor warranty.
 2. DO NOT wire two or more motors to one switch—No parallel wiring.
 3. All wiring must conform to NEC (National Electrical Code) and local codes.

1. Determine the final location of the switches.

NOTE: There is approximately 5 feet of wire from the wall entry point for upper wire routing, approximately 1 foot of wire from the wall entry point for lower wire routing. Controls should be located within this distance.

1.1. If the distance from point of entry to the switch location is greater than stated above, the installer must furnish a splice between the cables and switch location.

- For motor wires use 14awg wire.
- For LED wires use 18awg wire.

2. On the motor side:

2.1 For top routing, drill two (2) 5/16" holes through the pass through slots at the top of the arm.

2.2 For bottom routing drill one 7/16" hole as shown.

3. Route the cable through the hole to the switch location.

4. For the LED harness:

4.1 For installations with upper cable routing, route the LED harness into the vehicle with the motor cable.

4.2 For lower cable routing, refer to the wire routing preparation on page 5.

5. Seal the cables and entrance hole(s) using a quality filler and sealant.

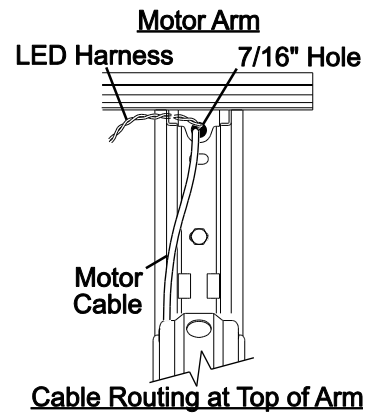

Cable Routing at Top of Arm

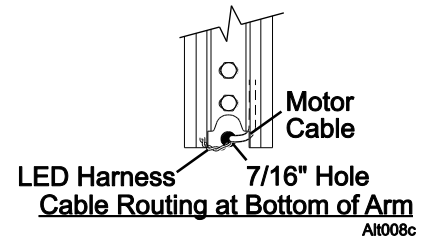

Cable Routing at Bottom of Arm

Alt008c

CONTROL SYSTEM

The SC12 Switch provides One-Touch controls for Power ON/OFF and the Extend/Retract functions in one convenient location. The switch can be used for new installations or upgrades for existing single switch installations.



WARNING SHOCK HAZARD. Always disconnect battery or power source before working on or around the electrical system.

1. Determine the location of the switch.
2. For new installations:
 - 2.1. Drill a 1" hole in the switch location.
NOTE: The mounting hole is offset below the center of the switch by .34".
3. For upgrade installations:
NOTE: The new switch will fit over the existing access hole in the mounting surface.
 - 3.1. Remove the existing switch.
 - 3.2. Pull the wires out through the existing hole.
 - 3.3. Cut off the switch connector. Leave adequate wire from the motor, power and ground for splicing to the new switch.
4. Route the motor wires from the awning motor to the switch position.
 - 4.1. Splice motor wire #1 to the Blue switch wire;
 - 4.2. Splice motor wire #2 to the White switch wire.
See chart for specific awning motor wire colors.

NOTE: If the wire run is longer than the supplied wires, use a minimum 16awg wire for runs 15 feet or less; use a minimum 14awg wire for runs longer than 15 feet. Splice wires are furnished by the installer.

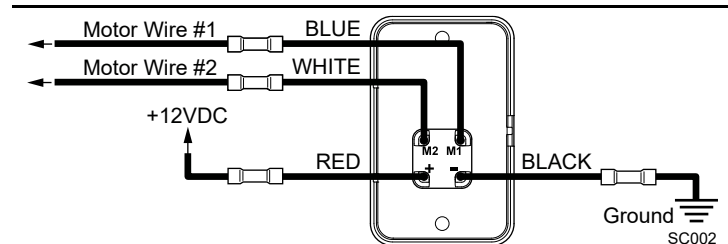
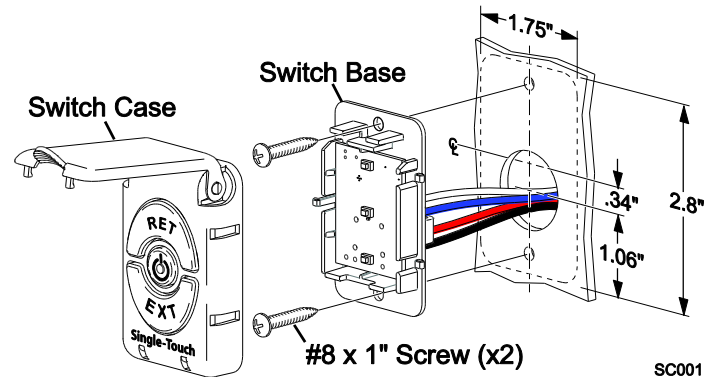

Switch Wire	Motor Wire #1	Switch Wire	Motor Wire #2
Altitude / Compass / Eclipse / Travel'r			
Blue	Black	White	Red
Freedom WM / Marquee			
Blue	Brown	White	Blue
Freedom RM			
Blue	Blue	White	Brown

5. Run a minimum 16awg wire from chassis ground to the switch location. Splice to the black (ground) switch wire. Suitable ground would be the vehicle chassis or conductive structure connected to the chassis.
6. Run a minimum 16 gauge wire from the power distribution panel (auxiliary battery circuit) or equivalent to the switch. The circuit should be protected by a 15 amp fuse. Splice to the red (+12VDC) switch wire.
NOTE: For power and ground, use a minimum 16awg wire for runs 15 feet or less; use a minimum 14awg wire for runs longer than 15 feet. Splice wires are furnished by the installer.
7. Press the wires and switch base into the mounting hole. Secure using two (2) #8 x 1" screws.
8. Snap the switch case over the switch base.

OPERATION*To Operate the Awning:*

- Press the power switch to ON. The indicator light will come on.
- To OPEN the awning: Press and release the extend (EXT) switch. The awning will open completely. To interrupt the awning extension, press and release the extend switch again. The awning will stop.
- To CLOSE the awning: Press and release the retract (RET) switch. The awning will close completely. To interrupt the awning retraction, press and release the retract switch again. The awning will stop.
- When the awning is in the retracted (rolled up) position, shut off the power switch to avoid accidentally extending the awning.

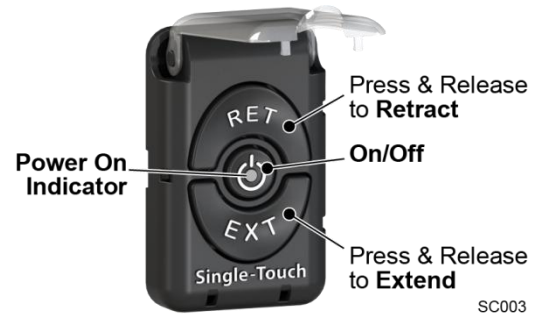

OPTIONAL LED'S

LED options available on the Altitude:

- 1) White LED strip mounted in the roller tube with the power harness routed through the canopy.
- 2) White LED strip mounted at the awning rail (strip holder is sewn to the canopy).

SWITCH INSTALLATION FOR LED'S

A single pole switch and 2A fuse is required for the white LED installations when not connected through the BT12 Control Module.

NOTES:

- a) Installers may choose to furnish the control switch. The installation requires that the power line (+12VDC) be attached to a dedicated 2A circuit breaker or a 2A in-line fuse must be installed between the switch and power source. For easy access, locate the fuse close to the switch.
- b) Per RVIA Low Voltage Systems in Conversion and Recreation Vehicles Chapter 3, Section 3-1: For Carefree LED strip lighting near the awning rail: when the 24AWG power harness is spliced or connected 10" or less from the harness connector using a heavier gauge wire, the fuse size is determined by the heavier wire gauge.

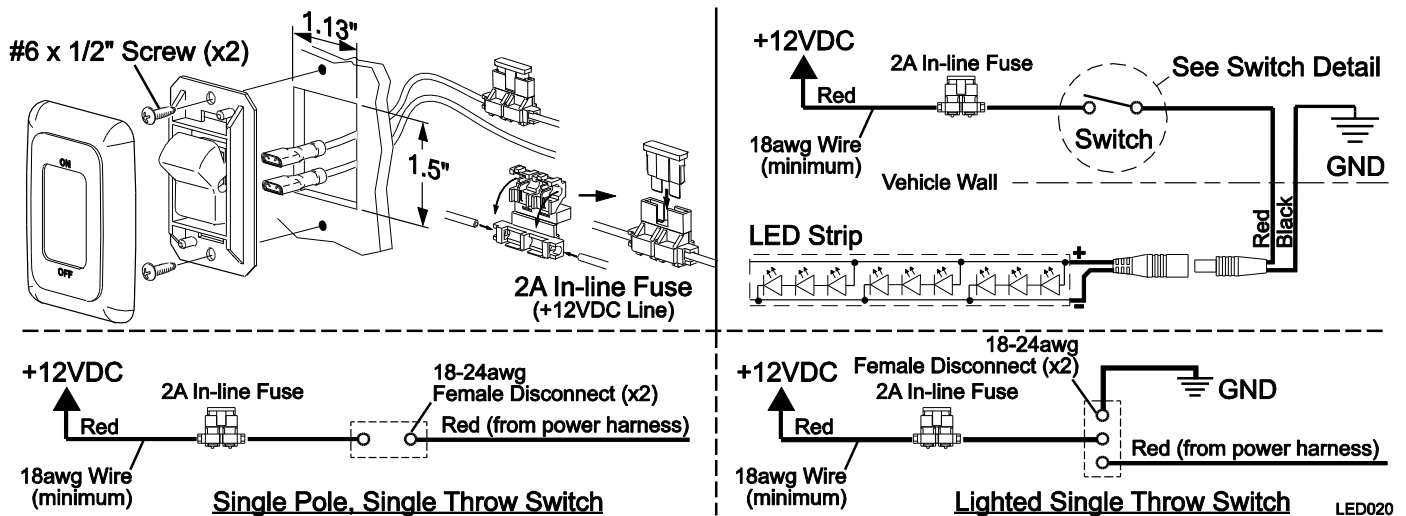

1. Determine the location of the switch.
 2. At the switch location, cut a 1 1/8" x 1 1/2" hole.
 3. Wire the switch as shown below. Wire terminals at the switch are .187, 18-24 awg female disconnects.
- NOTE:** Allow adequate slack in the 12VDC power line so that the in-line fuse (installed in step 4) can be accessed from behind the switch.
4. Install the in-line fuse:
 - 4.1. Near the switch, cut the red 12VDC power line to the switch. Do not strip the insulation.
 - 4.2. Insert a wire end into one of the wire channels until it butts up against the stop.
 - 4.3. Fold that half of the connector body over until the element contacts the wire. Use pliers to crimp the connector closed.
 - 4.4. Repeat for the second wire end.
 - 4.5. Slide the fuse into the fuse port. Ensure that is firmly seated.
 5. Press the in-line fuse, wires and switch into the mounting hole. Secure the switch using two (2) #6 x 1/2" screws.
 6. Snap the switch bezel over the switch frame.

OPTIONAL WIRE COVERS

Two optional wire covers are available for the Altitude.

For upper wire routing use the upper wire cover. The cover slides into the channel from the top and over the wires.

For lower wire routing use the lower wire cover. The cover snaps onto the bottom of the rear channel. The lower cover is purchased in sets of two (2). These can be applied to both arms for a balanced aesthetic appearance.

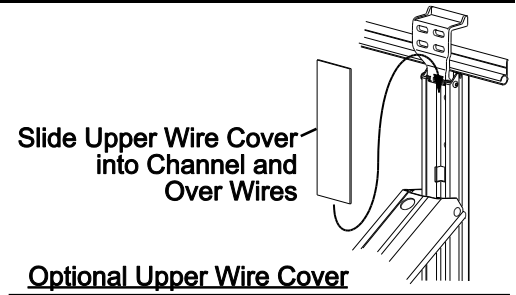

Optional Upper Wire Cover

Push Lower Cover Over End of Channel. Pins on Cover Snap into Holes in Channel

Optional Lower Wire Cover

