

INSTALLATION MANUAL

ALTITUDE ARMS WITH POWER PITCH AND CANOPY



Arm style code 46

Product styles codes:

“14,AE,AJ,AK,AL,AM,AN,CK,CW,CX,
CZ,DS,DZ,EC,ED,EH,EI,EJ,EK,EL,EM,
EN,FL,FM, FY,GY,GZ,HM,HW,HX,IL,
IM,IU,IZ,JB,JJ,KK,KL, KP,KQ,OS,
OT,OU,QL,QJ,QK,QZ,TO,TQ,TU,TY,TZ,UT”

THIS MANUAL PROVIDES INSTRUCTIONS FOR THE BASIC INSTALLATION OF THE
AWNING.

RV



Read this manual before installing or using this product. Failure to follow the instructions and safety precautions in this manual can result in personal injury and/or cause the product to not operate properly.



TABLE OF CONTENTS

Product Overview	1
Specifications:	1
Component Checklist.....	2
Installation	3
Required Pre-Installation Preparation	3
Installing an Awning Rail.....	3
Arm Wire Harness Routing Options	4
Cable Routing at the Top of the Arm.....	4
LED Harness Routing at the Bottom of the Arm with Cables.....	4
Cable Modification to Splice the Left and Right Connects Cables Together	4
Assembling the Awning	6
Mounting the Awning	7
Securing the Fabric.....	8

Switch and Wiring Installation	9
Wire Routing.....	9
Carefree Connects Power Cable	10
Accessory Harness.....	10
Awning Control Switch.....	11
Power Pitch Control.....	12
Optional LED's.....	13
Switch Installation for LED's.....	13
Power Connection for RGB LED's	14
Optional Wire Covers	15

PROPRIETARY STATEMENT

The Altitude Awning is a product of Carefree of Colorado, located in Broomfield, Colorado, USA. The information contained in or disclosed in this document is considered proprietary to Carefree of Colorado. Every effort has been made to ensure that the information presented in the document is accurate and complete. However, Carefree of Colorado assumes no liability for errors or for any damages that result from the use of this document.

The information contained in this manual pertains to the current configuration of the models listed on the title page. Earlier model configurations may differ from the information given. Carefree of Colorado reserves the right to cancel, change, alter or add any parts and assemblies, described in this manual, without prior notice.

Carefree of Colorado agrees to allow the reproduction of this document for use with Carefree of Colorado products only. Any other reproduction or translation of this document in whole or part is strictly prohibited without prior written approval from Carefree of Colorado.

SAFETY INFORMATION



This is the safety alert symbol. It is used to alert individuals to potential personal injury hazards. Obey all safety messages that follow this symbol to avoid possible personal injury or death.



Indicates a hazardous situation, which if not avoided, could result in death or serious bodily injury.



Indicates a hazardous situation, which if not avoided, may result in minor or moderate bodily injury.



Indicates a situation that may result in equipment-related damage.

General Safety:



This product can expose you to chemicals including Di-isodecyl phthalate (DIDP), Vinyl Chloride and Formaldehyde, which are known to the state of California to cause cancer or birth defects or other reproductive harm. For more information visit www.P65warnings.ca.gov



Shock Hazard. Always disconnect battery or power source before working on or around the electrical system.



Always wear appropriate safety equipment (i.e. goggles).



Always use appropriate lifting devices and/or helpers when lifting or holding heavy objects.



When using fasteners, do not over tighten. Soft materials such as fiberglass and aluminum can be "stripped out" and lose the ability to grip and hold.

PRODUCT OVERVIEW

The power pitch adjustment Altitude provides motorized awning comfort with Carefree's standards for looks, strength and dependability with a successful blend of style, quality and economy.

The powered pitch adjustment offers continuous settings from flat (3°) to steep (16°).

The awning roller tube and arms are made from light weight, no-rust aluminum. The awning fabric is heavy weight vinyl.

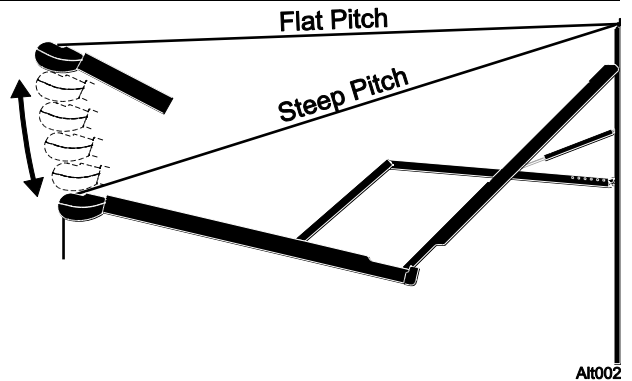

White and RGB LED lighting is available with the strip mounted in the roller tube or at the awning rail.

Specifications:

MAXIMUM EXTENSION:		88 inches	MAXIMUM LENGTH:		20 feet
PITCH:	FLAT	3°	DROP:	approximately 6 inches	
	STEEP	16°		approximately 26.5 inches	
Angle is Canopy vs horizontal			Measurement is from centerline of Awning Rail to centerline of roller tube		
MOTOR:	Power: 10VDC–14VDC	Circuit Rating: 15 amp	motor mounted in arm		
POWER SOURCE:	Motor and controls are routed and hardwired into the vehicle's 12V system				
EXTEND ACTUATION:	Gas Shock				
POSITION CONTROL:	Motorized roll out/in				
AWNING CONTROLLER: <i>NOTE: ORDERED SEPARATELY</i>	<u>Standard:</u> 3 position, momentary ON, center OFF; DC polarity reversing switch with dynamic brake.				
	<u>Optional:</u> BT12 Wireless Awning Control System				
COLOR:	Frame:	White, Black			
	Canopy:	Vinyl with Weatherguard or FLXguard. Refer to sales literature for options.			
LED	LED strip mounted in roller tube or at the awning rail				
	Power:	1A, 12VDC			
	Control	<u>White:</u> Single pole, single throw switch (SR0101) <i>Note: The Switch kit is ordered separately. Kit includes in-line fuse holder and 2A spade type fuse. For an installer furnished control switch, see note under "Switch Installation".</i>			
	<u>RGB</u>	IR (Infrared) Controller with sensor and remote.			

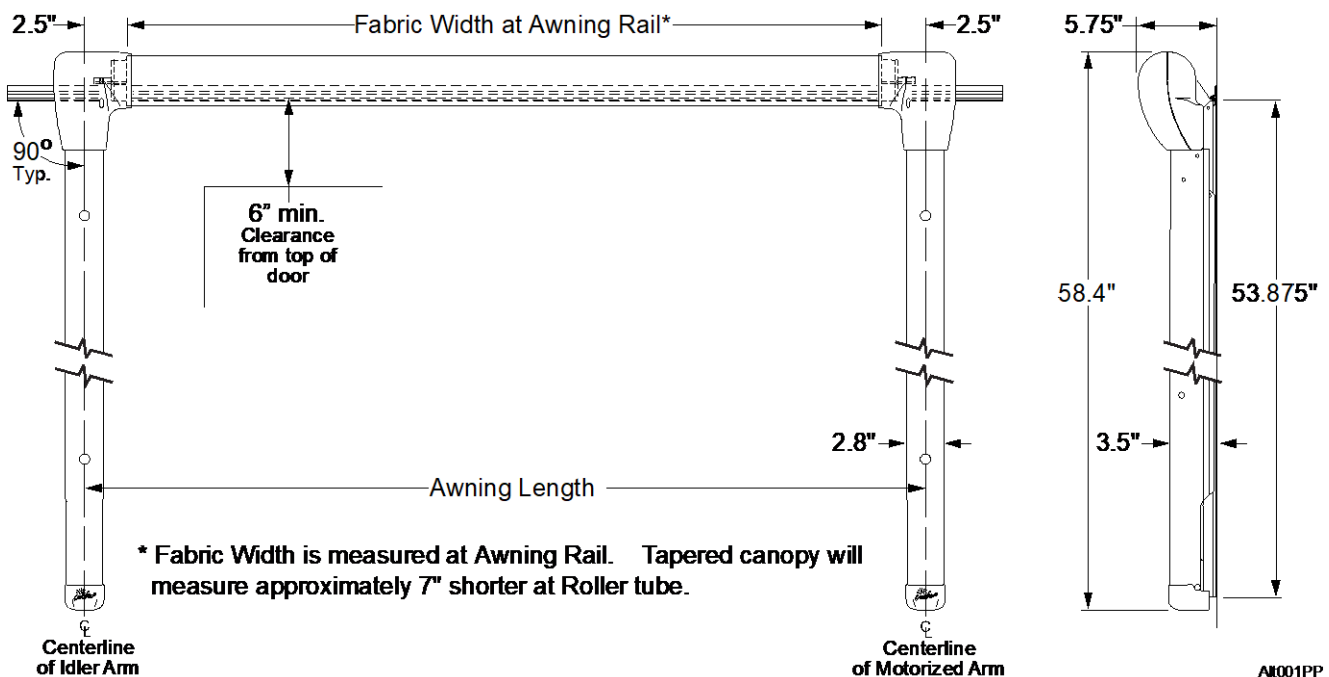

COMPONENT CHECKLIST

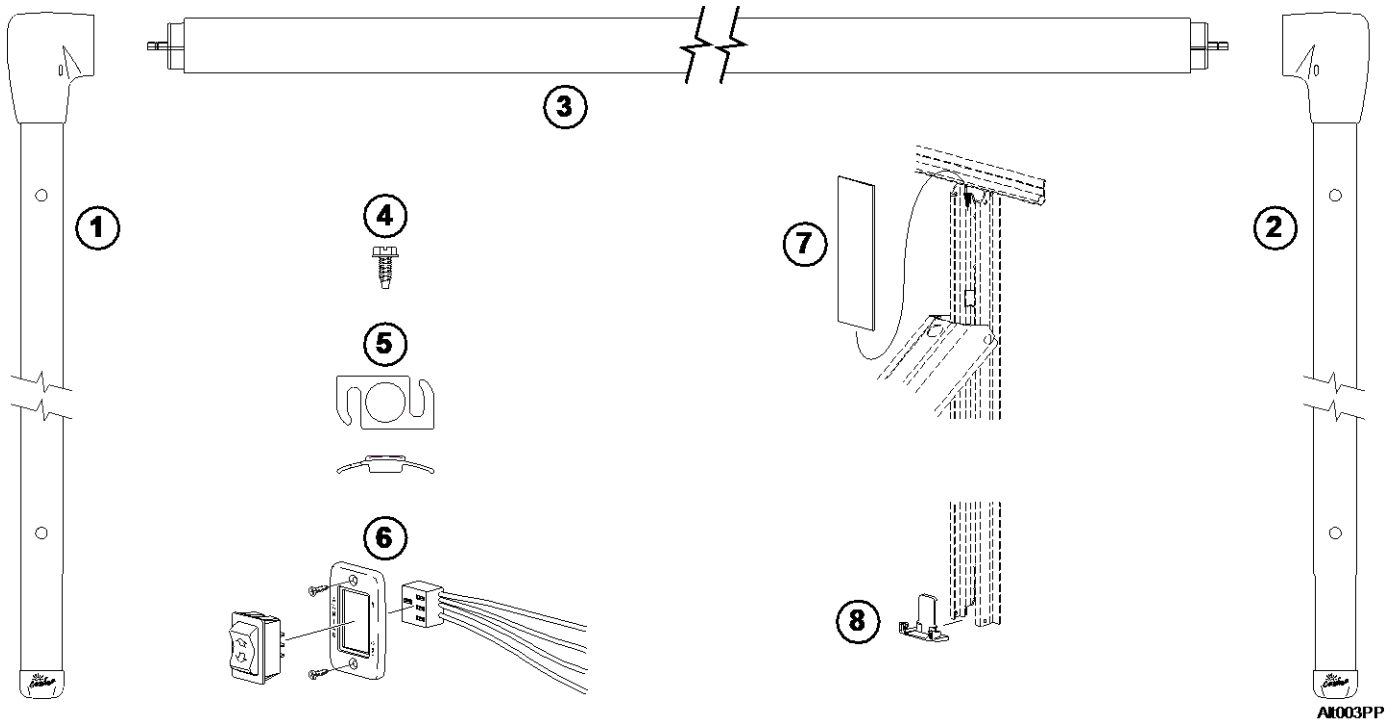

U	ITEM	DESCRIPTION	QTY	NOTE
<input type="checkbox"/>	1	Arm Assembly, LH	1	1
<input type="checkbox"/>	2	Arm Assembly, RH	1	1
<input type="checkbox"/>	3	Roller tube Assembly	1	1 Ordered Separately
<input type="checkbox"/>	4	Screw, Hex Washer Head	2	#6 x 3/8
<input type="checkbox"/>	5	Hole Plug	4	
<input type="checkbox"/>	6	Switch Kit	1	3, 4 Ordered Separately
<input type="checkbox"/>	7	Wire Cover, Upper, Optional	1	5
<input type="checkbox"/>	8	Wire Cover, Lower, Optional	1	5

- Notes:
1. Awning configuration is specified at time of order, including awning length, fabric, color etc. Check awning assembly against original purchase order. Arms are configuration specific and are not interchangeable.
 2. Attaching hardware is furnished by installer. Refer to "Mounting the Awning" for requirements.
 3. OEM's may choose to furnish the control switch. The switch must be a DC polarity reversing switch with dynamic brake. Not used with the BT12 Wireless Awning Control System.
 4. The Awning Control System is ordered separately. Refer to the sales literature for available options with the system.
 5. Wire Covers (7, 8) are optional and must be specified at time of order.

INSTALLATION

REQUIRED PRE-INSTALLATION PREPARATION

1. Park the vehicle on a flat surface and level the unit.
2. Check where the awning arms will be installed. The arms fit snug to the side of the vehicle and must not cover or interfere with exhaust vents, lights etc.
3. If there is an awning rail installed, check that the awning rail runs the full length of the awning. Please refer to the note under "Installing an Awning Rail" before proceeding.

INSTALLING AN AWNING RAIL

NOTE: If the vehicle already has a full-length awning rail installed, skip to step 5. The awning rail and arms must be positioned so that any existing trim does not interfere with the awning arm when in the closed position.

1. Determine the optimum positioning of the awning so that the arms will not interfere with the door frame or light fixtures. The centerline of the awning rail should be above the door opening a minimum of 6". After determining mounting position, mark the position with a chalk line.
2. Awning rail must be level.
3. Seal the back of the rail with silicone sealant or putty tape.
4. Align the awning rail onto the wall and secure with #10 x 3/4" screws. Use all the attach holes in the rail.
NOTICE Make sure the screws are securely mounted to the structural frame of the vehicle.
5. Use a screwdriver to spread open one end of the awning rail on the installation side.
6. File any sharp edges or burrs from the end of the rail. This will help protect the awning fabric from damage during installation.
7. Spray inside the awning rail track with a dry silicone lubricant.

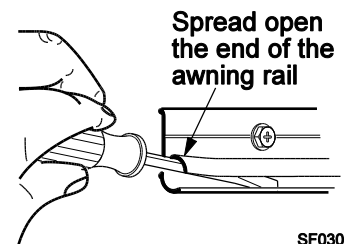

SF030

ARM WIRE HARNESS ROUTING OPTIONS

Several options are available for routing the harnesses through the arm for top or bottom entry into the vehicle.

Cable Routing at the Top of the Arm

1. Remove the cable tie at the top of the motorized arm. Partially open the arm being careful to not let the arm extend more than 6".



CAUTION The arm is under tension from the gas shock located in the arm.

2. Pull the cables from the back of channel and out the pass-thru hole in the top of the channel.
3. Close the arm.
4. Secure the top of the arm in the closed position using a plastic wrap or equivalent.

LED Harness Routing at the Bottom of the Arm with Cables

5. On back of the motor arm, carefully pull the Connects cable from the channel.

1. Route the LED harness through the routing slot on the side of the arm and down the channel on the back of the rail, along with the Power Pitch harness.

NOTE: Allow the LED harness to extend 3-4" past the top of the rail.

2. Press the Connects cable into the channel on top of the LED and Power Pitch harnesses.

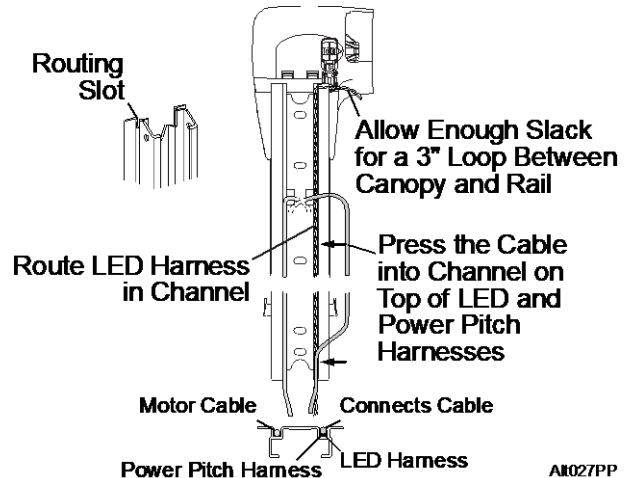

Cable Modification to Splice the Left and Right Connects Cables Together

This option is used when it is desirable to have only one entry hole for the cables at the bottom of the motor arm. This option uses a special canopy with an accessory harness attached to the canopy.

6. On back of the motor arm, carefully pull the Connects cable from the channel.

1. Route the LED harness through the routing slot on the side of the arm and down the channel on the back of the rail.

NOTE: Allow the LED harness to extend 3-4" past the top of the rail.

2. Loop the Connects cable 5-6" above the pass-thru hole and cut in two.
3. Press the cut ends into the arm channel through the pass-thru hole.
4. Press the remaining Connects cable into the channel on top of the LED harness.

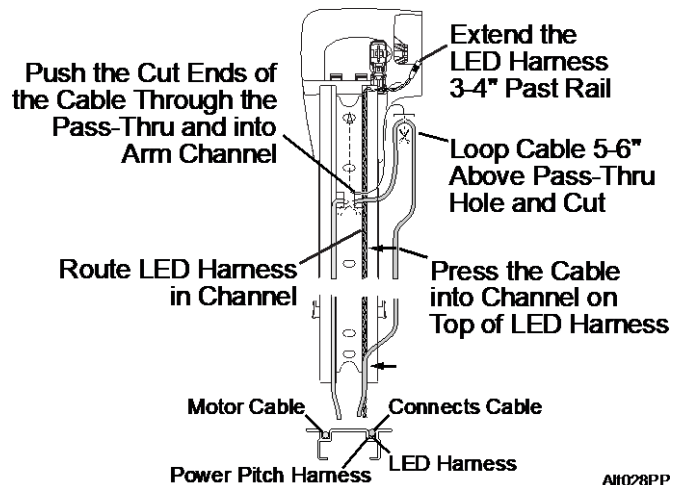

Cable Preparation to Route Idler Side Power Pitch Harness at Bottom of Drive Side Arm

This option is used when it is desirable to have only one entry hole for the Power Pitch wires at the bottom of the motor arm. This option uses a special canopy with an accessory harness attached to the canopy.

1. On the back of the idler arm, carefully pull the Connects cable and the Power Pitch harness from the entire length of the channel on the back rail.
2. Loop the Connects cable and Power Pitch harness 5-6" above the pass-thru hole and cut each in two.
3. Push the cut ends of the cables back through the pass-thru hole and into the arm channel.
4. Reserve the remaining length of Power Pitch harness and discard the remaining length of Connects cable.

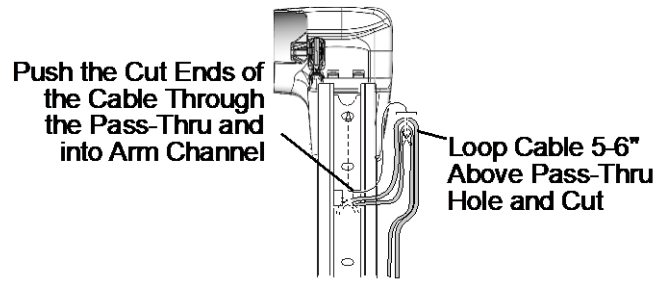

Alt028PPI

5. On the back of the motor arm, carefully remove the Motor cable from the entire length of the channel on the back rail.
6. Route the reserved length of Power Pitch harness down the channel on the back rail, leaving 5-6" of harness above the pass-thru hole.
7. Press the Motor cable into the channel on top of the Power Pitch harness.
8. Push the cut end of the Power Pitch Harness through the pass-thru hole and into the arm channel.

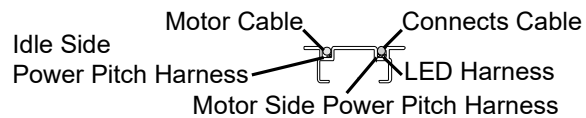
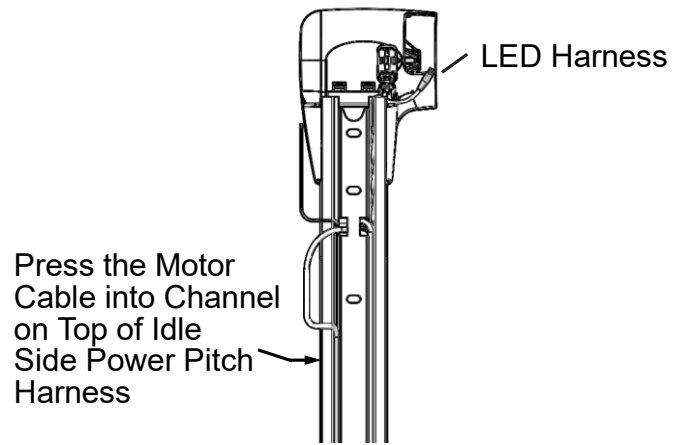

Alt028PPM

ASSEMBLING THE AWNING

1. Decide on the location of the switches to determine the cable routing (refer to page 4).
2. On the RH (motor) arm, press the roller tube shaft into the hole in the motor head. It may be necessary to twist the roller tube to align the flats on the roller tube shaft with the flats in the motor head bearing.

NOTE: The retaining clips are factory installed in the rear head cover as shown.

3. With the roller tube shaft FULLY INSERTED, press the retaining clip onto the shaft. The clip goes in only when the shaft is fully inserted. Press the clip until it is firmly seated in the groove of the roller tube shaft.

NOTICE The roller tube must be fully inserted into the head for the clip to align with the groove on the shaft. The roller tube can disengage if the clip does not seat in the groove of the shaft.

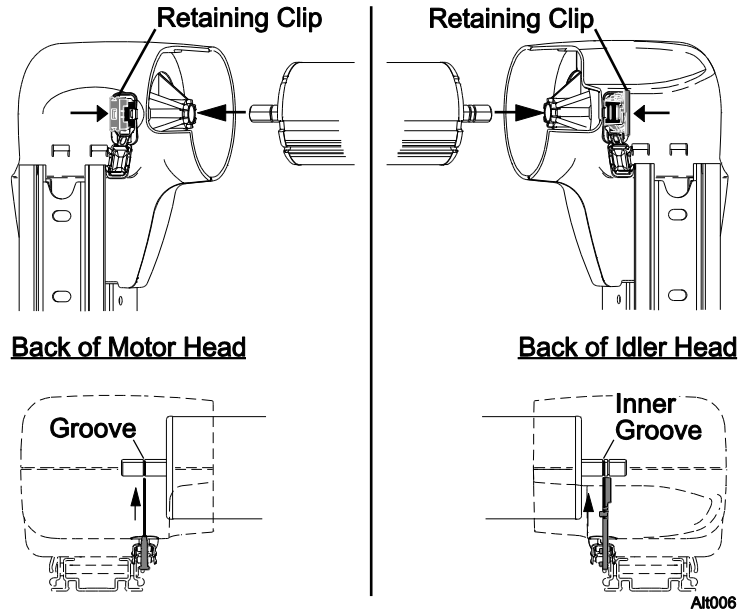

4. On the LH (idler) arm, press the roller tube shaft into the hole in the idler head.
5. With the roller tube shaft fully inserted, press the retaining clip onto the shaft. Move the roller tube shaft until the clip aligns with the inner groove of the shaft. Press the clip until it is firmly seated in the groove of the shaft.

IMPORTANT NOTE: DO NOT remove the plastic covers from the retaining clips until instructed to do so.

NOTICE During assembly and installation, the arm assemblies must remain perpendicular to the roller assembly. Failure to handle the arm assemblies carefully can bend the drive shaft.

MOUNTING THE AWNING

NOTICE It is recommended that at least three people install the awning due to its size and weight.

NOTE: Attaching hardware is furnished by installer.

1. Check the location where the awning is to be mounted. Ensure that the awning will not interfere with other equipment on the vehicle, such as a slide out room, light fixtures, exhaust vents etc.
2. On the awning rail, mark the location of the centerline of the idler and motor arm assemblies.
3. Unroll the canopy one wrap.

NOTE: While the awning fabric is fairly robust, care must be taken not to snag it on the awning rail.

4. With one person holding each arm, the third person should thread the polyrod (the plastic rod on the edge of the fabric) into the awning rail. Carefully move across the vehicle, gently pulling the fabric into the rail, until the awning is in the desired location.

NOTE: For awning rail LED's: the LED rail adaptor is attached to the canopy. The adaptor and canopy slides into the awning rail together.

5. Position the idler arm on the coach: Align the center of the idler arm with the centerline marked in step 2. Butt the top of the rear channel against the awning rail as shown.
6. Hold the idler arm in position and drive a screw through the upper access hole (▲) and rear channel into the vehicle wall.
7. Confirm that the arm is perpendicular to the awning rail then drive a screw through the lower access hole (▲) and rear channel into the vehicle wall.
8. Hold the motor arm assembly perpendicular to the awning rail and drive a screw through the upper access hole (▲) and rear channel into the vehicle wall.
9. Confirm that the arm is perpendicular to the awning rail then drive a screw through the lower access hole (▲) and rear channel into the vehicle wall.
10. Hold the awning closed and carefully remove the cable ties at the top of the arms. The awning will open a few inches.
11. Open the awning to access the remaining mounting holes. To open:
 - 11.1. Temporarily connect the ends of the motor wires to a 12V-14V source (i.e. drill battery). If the awning does not begin to move, reverse the leads.
 - 11.2. Remove the battery after the awning is open.
12. Attach each arm in the additional positions (marked with an *) shown (4 places per arm).

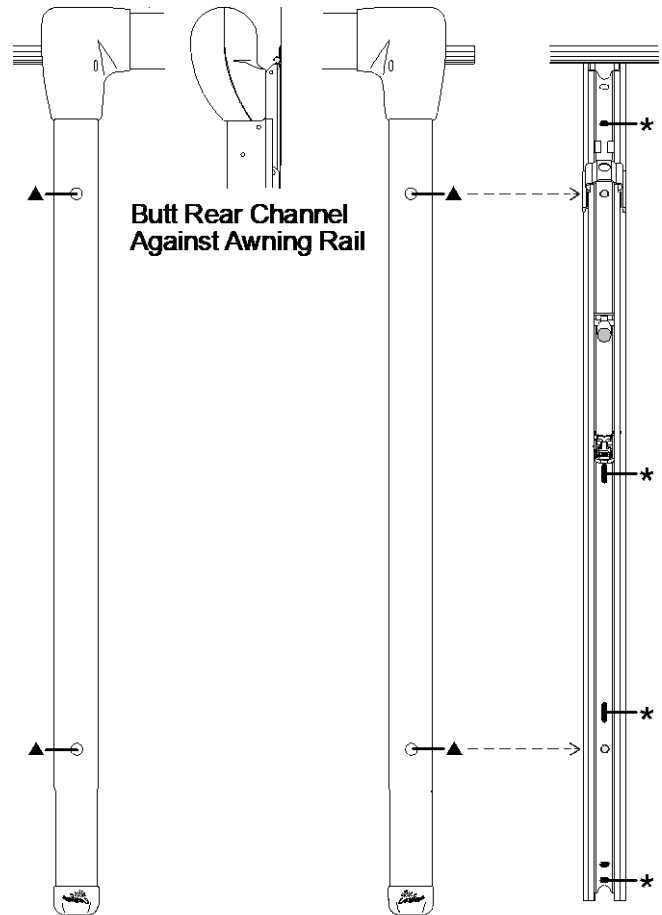

NOTE: Attaching hardware is furnished by installer.

If mounting into structure: Use #14 x 1 1/2" lag screws or equivalent. Requires a 5/32" pilot hole.

If mounting to the outer skin only: Use 3/16" moly rivets. Requires a 7/32" (#4) hole.

AR004PP

13. On the back of the motor and idler heads, remove the plastic retaining clip covers and discard.
14. Rotate the access covers up and snap into the retaining clip openings.

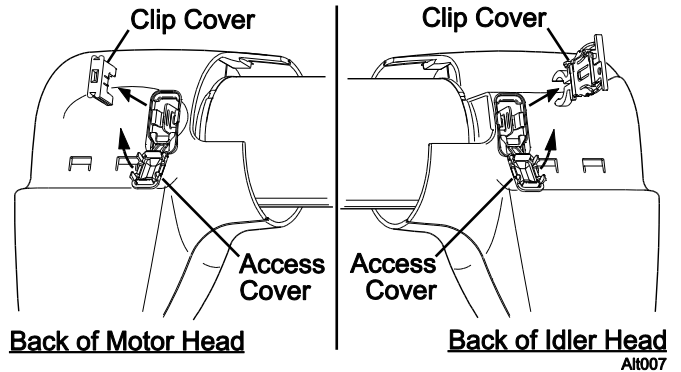

15. Install the hole plugs in the front channel:
 - 15.1. From the back of the channel, insert the plug into the hole.
 - 15.2. Twist to lock into place.

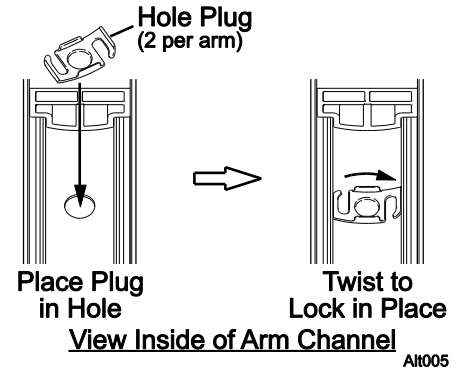

SECURING THE FABRIC

1. Roll the awning in and out several times to make sure that the fabric rolls up straight.
2. Attach the canopy in the awning rail using one #6 x 3/8" hex head screw on one side of the awning. Place screw through awning rail, fabric and polyrod approximately 1" in from the end of the fabric.
3. On the opposite side, pull the fabric tight in the awning rail place one #6 x 3/8" hex head screw on one side of the awning. Place screw through awning rail, fabric and polyrod approximately 1" in from the end of the fabric.

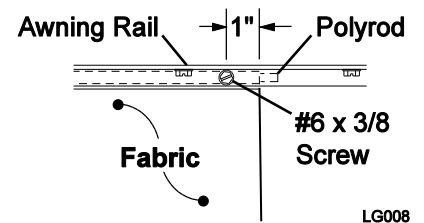

SWITCH AND WIRING INSTALLATION



! WARNING Shock Hazard. Always disconnect battery or power source before working on or around the electrical system.

- Notes:**
1. Failure to follow the wiring instructions in this publication may void the motor warranty.
 2. DO NOT wire two or more motors to one switch—No parallel wiring.
 3. All wiring must conform to NEC (National Electrical Code) and local codes.
 4. OEM's may choose to furnish the control switch. The switch must be a DC polarity reversing switch with dynamic brake.

WIRE ROUTING

1. Determine the final location of the switches.

NOTE: There is approximately 5 to 8 feet of wire from the wall entry point for upper wire routing, approximately 1-4 feet of wire from the wall entry point for lower wire routing. Controls should be located within this distance.

1.1. If the distance from point of entry to the switch location is greater than stated above, the installer must furnish a splice between the cables and switch location.

- For motor wires use 14awg wire.
- For Connect wires use 16awg wire.
- For LED and Power Pitch wires use 18awg wire.

2. On the motor side, drill a 7/16" hole through the vehicle wall to route cables into vehicle.
3. On the idler side, drill a 5/16" hole through the vehicle wall to route the Connects cable and Power Pitch harness into vehicle.

NOTE: See page 10 for using the accessory harnesses for routing the Connects cable and Power Pitch harness.

4. Route the cables through the hole to the switch location.
5. For the LED harness:
 - 5.1 For installations with upper cable routing, route the LED harness into the vehicle with the motor cable.
 - 5.2 For installation with lower cable routing, refer to the wire routing on page 4.

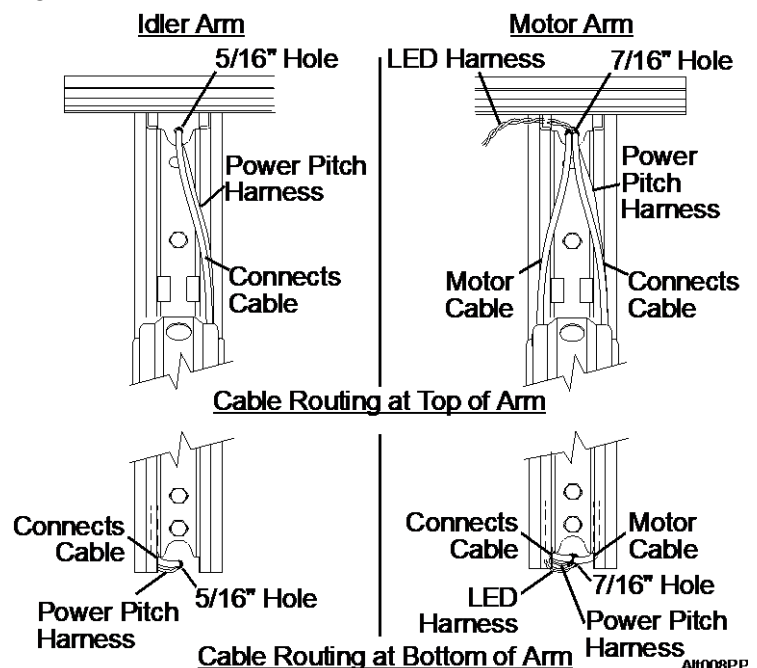

6. Seal the cables and entrance hole using a quality filler and sealant.

CAREFREE CONNECTS POWER CABLE

An accessory power cable is installed in the motor and idler arms. These are for optional Carefree Connects. Contact your sales representative for options and availability.

It is recommended that the cables be connected to a single 5A circuit.

Route the cables into the vehicle and connect to power and ground as shown.

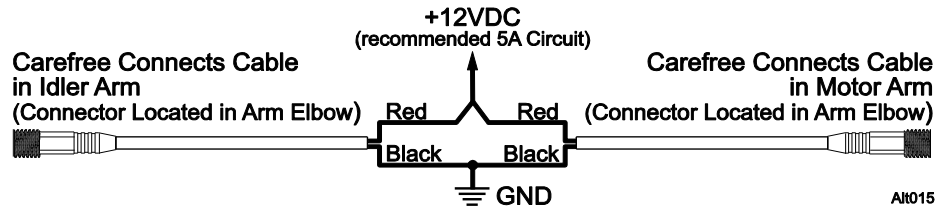

Accessory Harness

Some installers may wish to have a single wire entry hole into the vehicle at the bottom of the motor side arm. A special canopy from Carefree contains accessory harnesses at the awning rail that allows the Connects cable and Power Pitch Harness from both arms to be routed into the vehicle at a single location

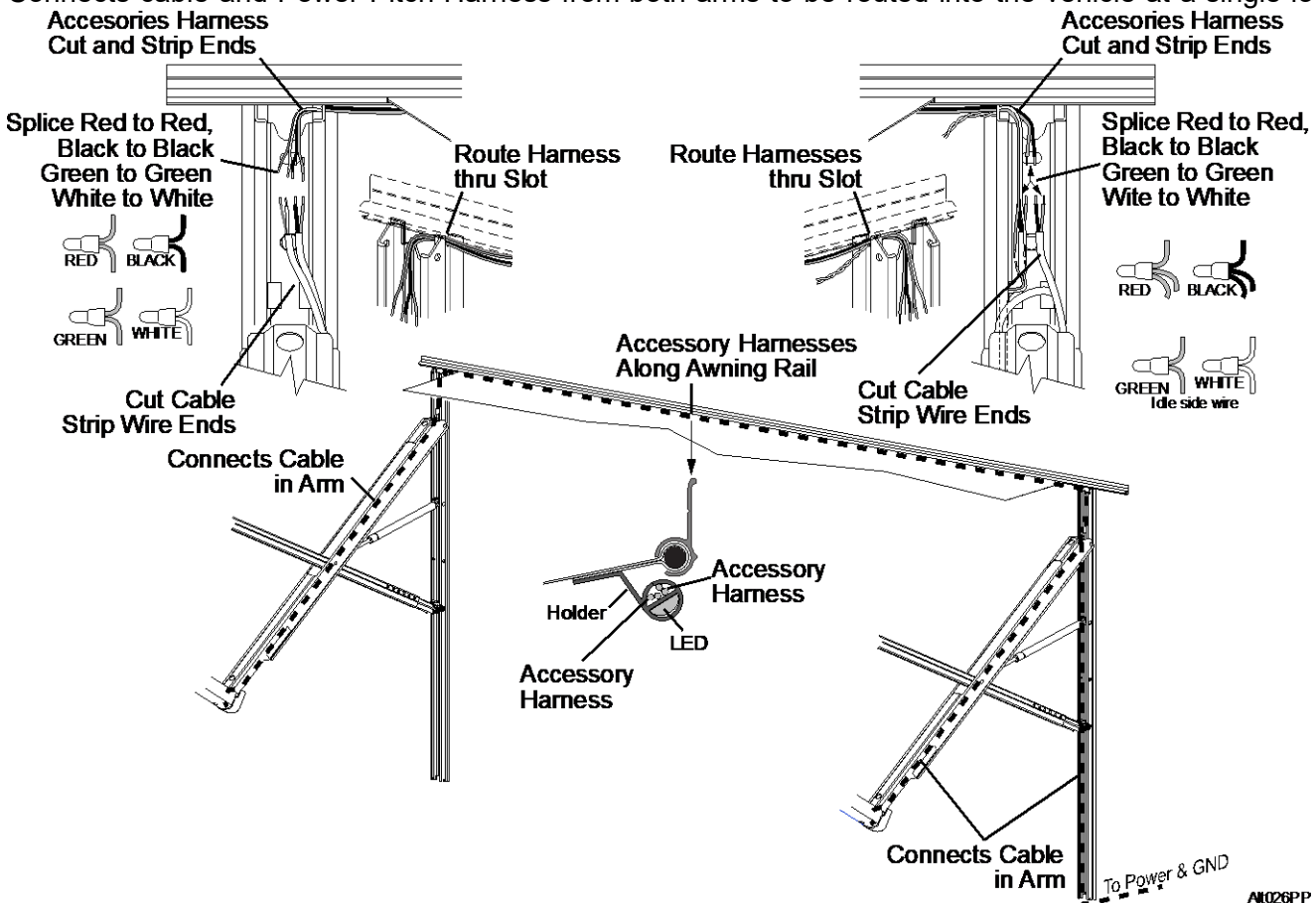

1. On the idler side:
 - 1.1. Route the accessory harnesses from the canopy through the slot of the rear rail.
 - 1.2. Trim and strip the wires from the Connects cable, Power Pitch harness and both accessory harnesses.
 - 1.3. Splice the wires together matching the wire colors (red to red, black to black, green to green, white to white)
2. On the motor side:
 - 2.1. Route the harnesses from the canopy through the slot of the rear rail.
 - 2.2. Trim and strip the wires from the Connects cable, Power Pitch harness and both accessory harnesses.
 - 2.3. Splice the wires together, matching wire colors (red to red, black to black, green to green, white to white).
3. After the harness is routed into the vehicle, connect to the appropriate power source.



If installing the BT12 Wireless Awning Control System use the wiring and setup instructions in "070029-001 BT12 Installation Manual".

Manual is available on-line at www.carefreeofcolorado.com/carefreeconnects.

AWNING CONTROL SWITCH

1. At the switch location, cut a rectangular hole 1.25" [3.2cm] x 1.88" [4.8cm].
2. Determine the switch orientation:
 - 2.1. The wires of the connector extend from the side of the switch with 3 terminals on the back.
 - 2.2. For wire routing on the right side of the switch as shown orient the switch with the 3 terminals on the right.
 - 2.3. For wire routing on the left side of the switch as shown in Detail C, orient the switch with the 3 terminals on the left.
 - 2.4. Push the switch into the faceplate until the tabs on the switch "click" into place behind the faceplate. Ensure that the switch and faceplate are oriented so that the lettering is up and the wires are oriented as desired.
 - 2.5. Set switch aside.

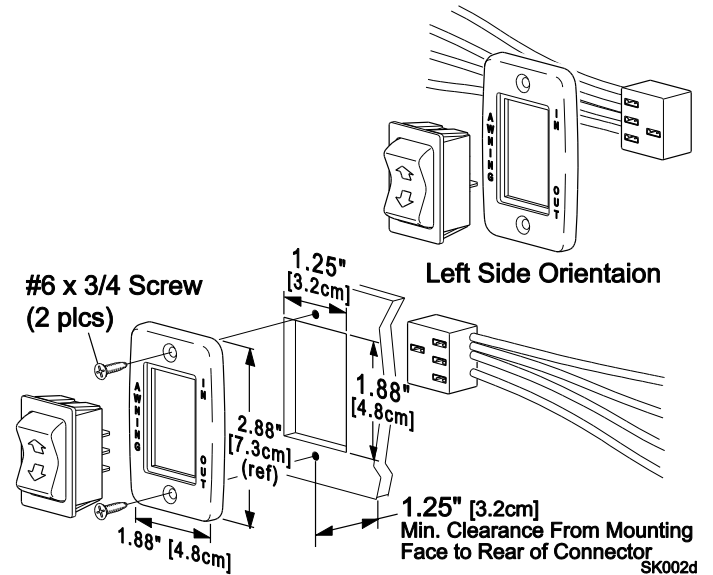

3. Route the awning motor wires through the switch hole and attach to the switch connector:

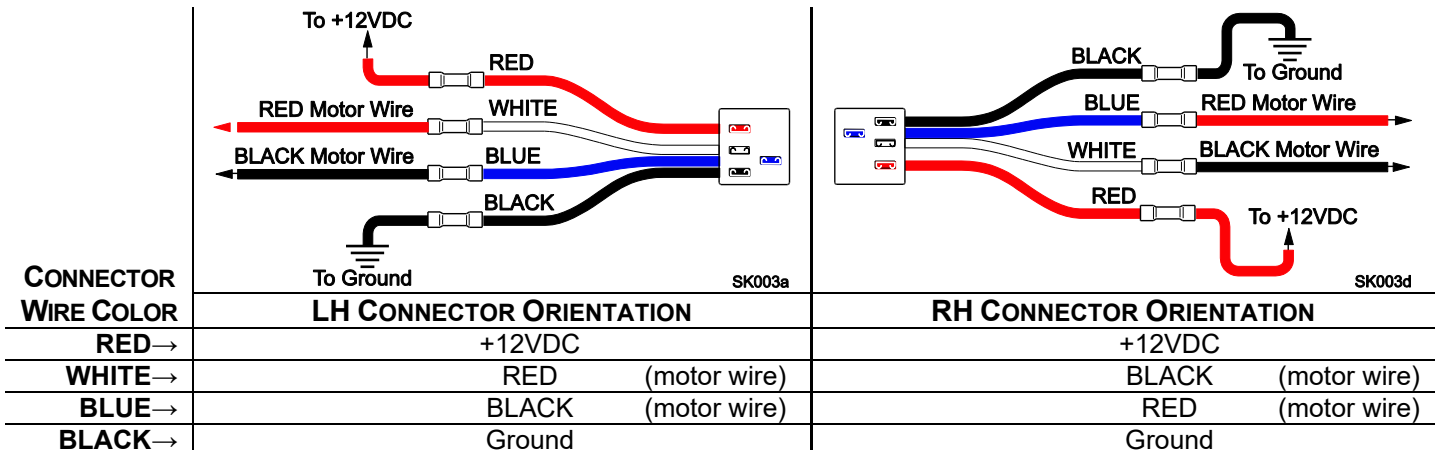

4. Run a minimum 14 awg wire from the power distribution panel (auxiliary battery circuit) or equivalent. The circuit should be protected by a 15-amp fuse.
5. Run a minimum 14 awg wire to system ground.

NOTE: If the wire run is 30 feet or longer, use 12awg wire to prevent voltage drop.
6. Route the two wires through the mounting hole. Butt splice the 12VDC wire to the RED connector wire. Butt splice the ground wire to the BLACK connector wire.
7. Attach the connector to the switch.
8. Restore power and test the switch operation. If the awning operates opposite to the switch plate markings:
 - Shut off power;
 - Reverse motor wires connected to the blue and white connector wires;
 - Restore power and test.
9. Push the wires, connector and switch into the mounting hole and secure the switch plate. Use two (2) #6 x 3/4" flat head screws.

POWER PITCH CONTROL

- 1. Power Pitch armsets are designed to work with current multiplexing control systems.
- 2. Orientation of power: White +12VDC pitch flattens, Green +12VDC pitch steepens.

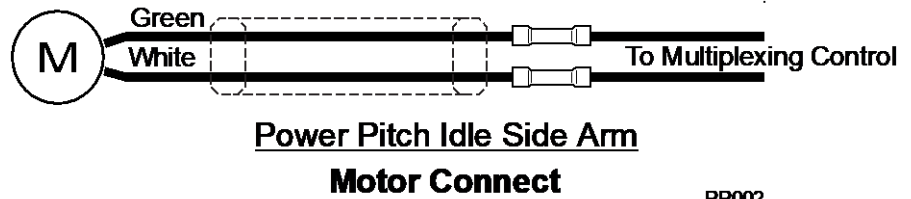
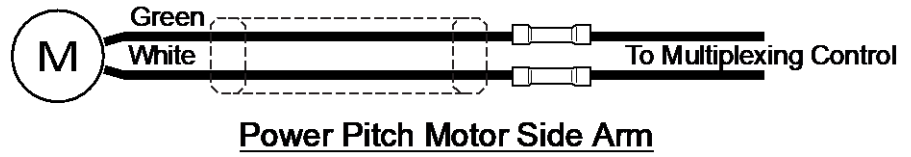

PP002

OPTIONAL LED'S

LED options available on the Altitude:

- 1) White LED strip mounted in the roller tube with the power harness routed through the canopy.
- 2) RGB LED strip mounted in the roller tube with the power harness routed through the canopy.
- 3) White LED strip mounted at the awning rail (strip holder is sewn to the canopy).
- 4) RGB LED strip mounted at the awning rail (strip holder is sewn to the canopy).

SWITCH INSTALLATION FOR LED'S

A single pole switch and 2A fuse is required for the white LED installations and is optional for RGB installations. For RGB lights, the single pole switch is used as an optional power on/off control allowing the lights to be shut off if the awning is retracted with the lights on.

NOTES:

- a) Installers may choose to furnish the control switch. The installation requires that the power line (+12VDC) be attached to a dedicated 2A circuit breaker or a 2A in-line fuse must be installed between the switch and power source. For easy access, locate the fuse close to the switch.
- b) Per RVIA Low Voltage Systems in Conversion and Recreation Vehicles Chapter 3, Section 3-1: For Carefree LED strip lighting near the awning rail: when the 24AWG power harness is spliced or connected 10" or less from the harness connector using a heavier gauge wire, the fuse size is determined by the heavier wire gauge.

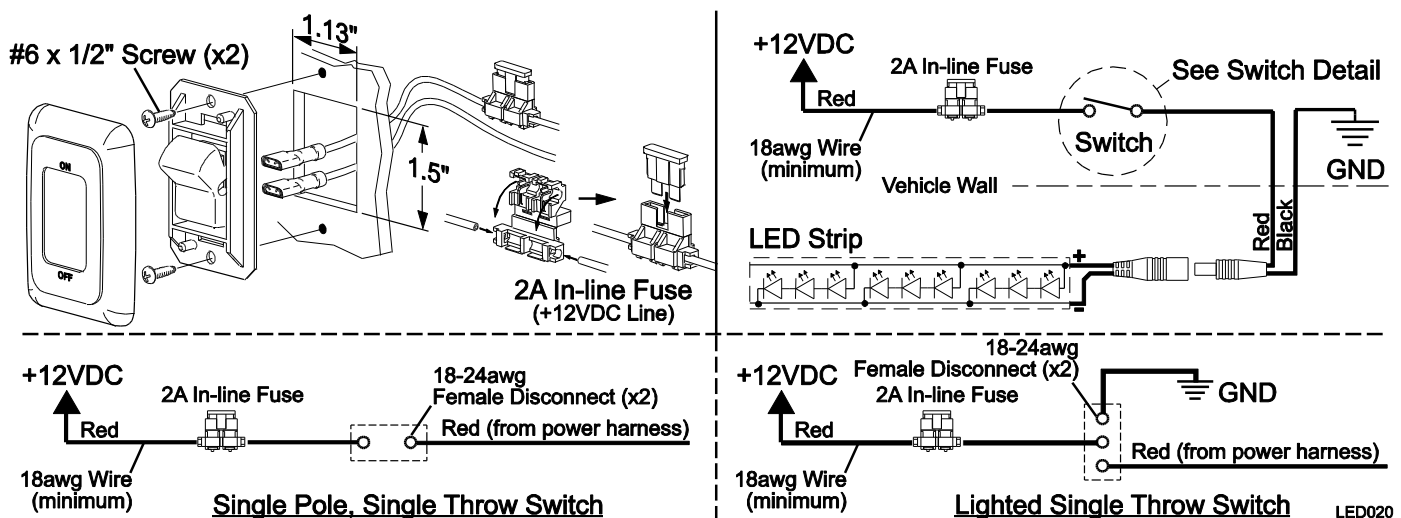

1. Determine the location of the switch.
 2. At the switch location, cut a 1 1/8" x 1 1/2" hole.
 3. Wire the switch as shown below. Wire terminals at the switch are .187, 18-24 awg female disconnects.
- NOTE:** Allow adequate slack in the 12VDC power line so that the in-line fuse (installed in step 4) can be accessed from behind the switch.
4. Install the in-line fuse:
 - 4.1. Near the switch, cut the red 12VDC power line to the switch. Do not strip the insulation.
 - 4.2. Insert a wire end into one of the wire channels until it butts up against the stop.
 - 4.3. Fold that half of the connector body over until the element contacts the wire. Use pliers to crimp the connector closed.
 - 4.4. Repeat for the second wire end.
 - 4.5. Slide the fuse into the fuse port. Ensure that is firmly seated.
 5. Press the in-line fuse, wires and switch into the mounting hole. Secure the switch using two (2) #6 x 1/2" screws.
 6. Snap the switch bezel over the switch frame.

POWER CONNECTION FOR RGB LED'S

The RGB LED uses a controller and remote.

NOTES:

- a) The installation requires that the power line (+12VDC) be attached to a dedicated 2A circuit breaker or a 2A in-line fuse must be installed between the control module and power source. Locate the fuse for easy access. Fuse and connector are furnished by the installer.
- b) Per RVIA Low Voltage Systems in Conversion and Recreation Vehicles Chapter 3, Section 3-1: For Carefree LED strip lighting near the awning rail: when the 24AWG power harness is spliced or connected 10" or less from the harness connector using a heavier gauge wire, the fuse size is determined by the heavier wire gauge.

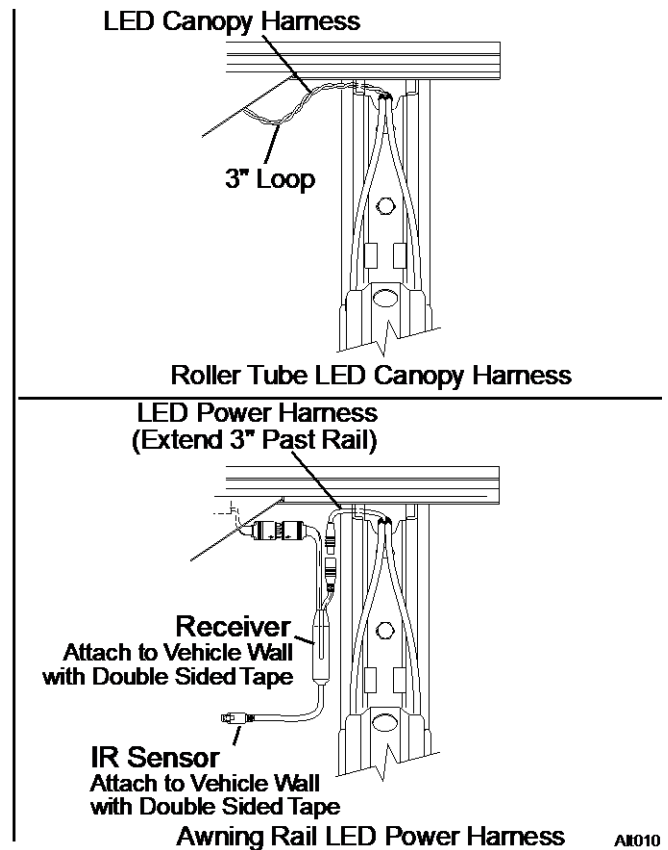
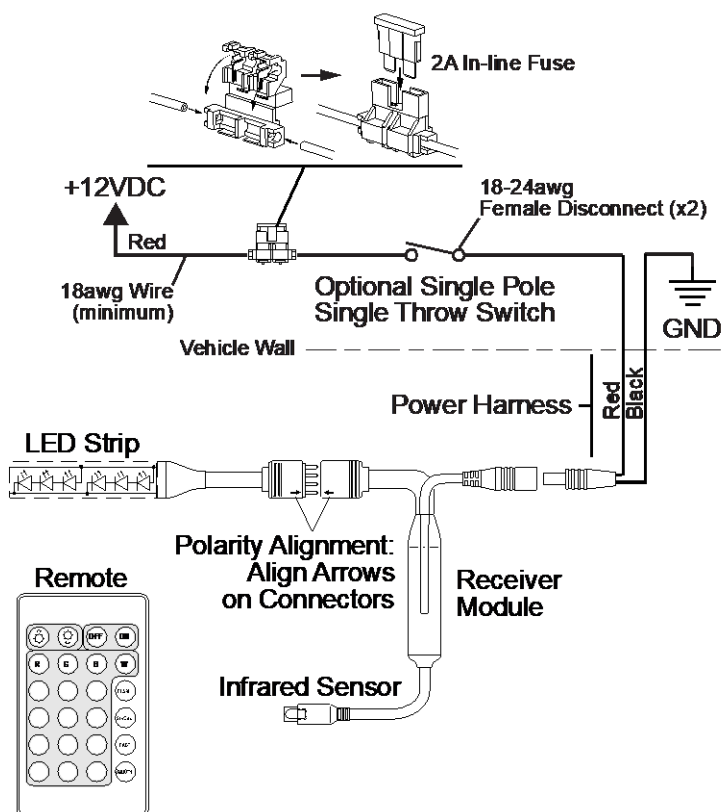

1. Route the power cable into the vehicle.
2. Attach the Red wire to +12Vdc.
3. Attach the Black wire to ground.
4. Ensure that the connections are tight, solid and sealed when completed.
5. For awning rail applications:
 - 5.1. Mount the control module and IR sensor on the outside of the vehicle as shown using double sided tape.
 - 5.2. Connect the module wires to the power harness and LED strip.

NOTE: The LED connector and receiver connector must be oriented with the arrows on the connectors lined up. The lights will not work if the connectors are not properly oriented.

OPTIONAL WIRE COVERS

Two optional wire covers are available for the Altitude.

For upper wire routing use the upper wire cover. The cover slides into the channel from the top and over the wires.

For lower wire routing use the lower wire cover. The cover snaps onto the bottom of the rear channel. The lower cover is purchased in sets of two (2). These can be applied to both arms for a balanced aesthetic appearance.

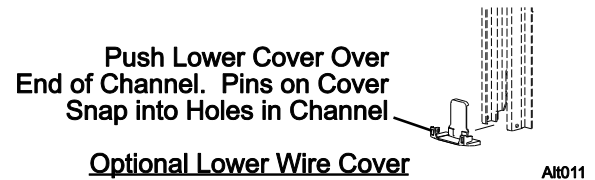
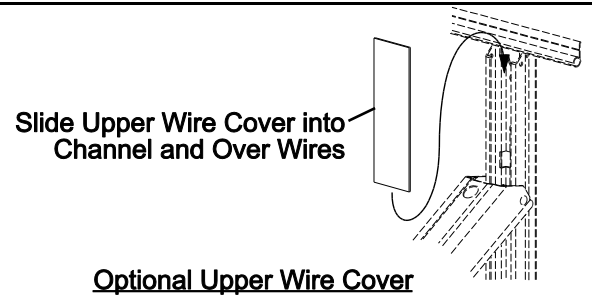

Alt011

OEM Representative (please print)

OEM Signature

OEM Position

Date

Carefree Representative (please print)

Carefree Signature/Date

Disclaimer: Carefree performs audits as a service for our customers to help identify situations where installations may not conform to installation instructions, and to identify any potential installation errors. Audits are a random, one-time checkin time and do not verify all the attributes specified in the installation instructions. Carefree cannot be held responsible for any damage or costs as a result of incorrect installation. OEMs must always install products according to installation instructions. This document does not constitute liability or culpability on Carefree’s part for incorrect installations performed by the OEM, dealer, service provider or the consumer.