



SERVICE MANUAL

FREESTYLE RM

12V MOTORIZED ROOF MOUNTED BOX AWNING W/ DIRECT RESPONSE

RV



Read this manual before installing or using this product. Failure to follow the instructions and safety precautions in this manual can result in personal injury and/or cause the product to not operate properly.



These instructions apply to all models listed. Details and procedures unique to a specific model are labeled appropriately.

TABLE OF CONTENTS

Product Overview	1
Standard System Adjustments	2
Manual Override	2
Original Configuration.....	2
Current Configuration	2
Adjusting the Pitch.....	2
Adjusting the Motor Limits.....	3
Out Limit Switch	3
IN Limit Switch	3
Standard Maintenance.....	4
Fabric Care	4
Mildew.....	4
Pooling.....	4
Motor Maintenance	4
Arm Noise	4
Canopy Replacement (Original Configuration).....	5
Canopy Replacement (Current Configuration)	6
Spring Arm Replacement.....	8
Lead Rail Connector.....	8
Removing the Lead Rail Connector.....	8
Attaching the arm to the Lead Rail	8
Replacing the Arm	9
Motor Replacement	11
Preliminary Steps (All Configurations).....	11
Replacing the Motor (Original Configuration)	12
Replacing the Motor (Current Configuration).....	13
Replacing the Direct Response Control Module	14
Wiring Diagram Freestyle RM.....	15
With Direct Response	15
With Direct Response and Lead Rail Position Switch	15
Part Number Listing	16
Part Number/Serial Number Location	16
Freestyle RM Illustrated Parts List (Original Configuration)	16
Freestyle RM Illustrated Parts List (Current Configuration)	18
Freestyle RM Bracket Kits	20

PROPRIETARY STATEMENT

The Freestyle RM is a product of Carefree of Colorado, located in Broomfield, Colorado, USA. The information contained in or disclosed in this document is considered proprietary to Carefree of Colorado. Every effort has been made to ensure that the information presented in the document is accurate and complete. However, Carefree of Colorado assumes no liability for errors or for any damages that result from the use of this document.

The information contained in this manual pertains to the current configuration of the models listed on the title page. Earlier model configurations may differ from the information given. Carefree of Colorado reserves the right to cancel, change, alter or add any parts and assemblies, described in this manual, without prior notice.

Carefree of Colorado agrees to allow the reproduction of this document for use with Carefree of Colorado products only. Any other reproduction or translation of this document in whole or part is strictly prohibited without prior written approval from Carefree of Colorado.

SAFETY INFORMATION



This is the safety alert symbol. It is used to alert individuals to potential personal injury hazards. Obey all safety messages that follow this symbol to avoid possible personal injury or death.



Indicates a hazardous situation, which if not avoided, could result in death or serious bodily injury.



Indicates a hazardous situation, which if not avoided, may result in minor or moderate bodily injury.



Indicates a situation that may result in equipment-related damage.

General Safety:



This product can expose you to chemicals including Di-isodecyl phthalate (DIDP), Vinyl Chloride and Formaldehyde, which are known to the state of California to cause cancer or birth defects or other reproductive harm. For more information visit www.P65warnings.ca.gov



Shock Hazard. Always disconnect battery or power source before working on or around the electrical system.



Always wear appropriate safety equipment (i.e. goggles).



Always use appropriate lifting devices and/or helpers when lifting or holding heavy objects.



When using fasteners, do not over tighten. Soft materials such as fiberglass and aluminum can be "stripped out" and lose the ability to grip and hold.

PRODUCT OVERVIEW

The Freedom Awnings are state of the art lateral arm awnings. When retracted, the housing provides protection against the elements while the streamlined styling blends in with the coach sidewall. The full tension canopy fabric allows the awning to be partially or fully extended for best shade coverage.

Each unit is equipped with lateral support arms. No vertical arms interfere with coach sidewalls, custom graphics or equipment that may be mounted on the sidewalls.

Freedom Awning Specifications:

- Fully retractable and self storing;
- Available as manual or motorized;
- The sealed awning motor operates on standard 12VDC (range 10VDC to 14VDC);
- Case and frame are constructed of high-strength aluminum extrusions, protected with a polyester paint finish;
- Optional white LED light strip mounted in lead rail is available.
- Freestyle RM is a 12V motorized awning with Direct Response Controls.

SPECIFICATIONS

Lengths:	centimeters	200 - 241	244 - 254	257 - 297	300 - 500
	inches	79 - 95	96 - 100	101 - 117	118 - 197
Extension:		152cm (60")	180cm (72")	200cm (80")	250cm (98")

NOTE: Actual awning Length = 2.69" [6.8cm] shorter than stated length

LEADING EDGE POSITION ACTUATION AND CONTROL

Power:	Lateral Arm Spring	Minimum Tension:	Open
Position Control:	Motorized:	Roll Out/In Controlled by Electrical Motor	12V Direct Response

MOTOR SPECIFICATIONS

Motor Type:	Tubular
Power:	12VDC Minimum: 10VDC Output: 30 Watts
	Nominal Current: 2.5Amps Max Current: 14Amps (stall @ min voltage)
Power Source:	Motor and controls are routed and hardwired into the vehicle's 12V system
Torque	Continuous: 6Nm/4.5 ft-lbs.
Speed	24 rpm

COLORS AVAILABLE

Case	Satin, White or Black
Fabric: ¹	Vinyl

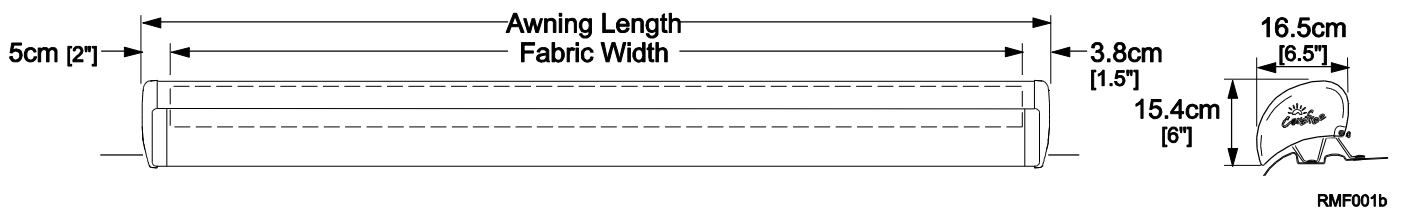

There are two configurations of the Freestyle RM. The original configuration is identified by the five (5) screws in the endcap. The current configuration has one (1) screw in the endcap.

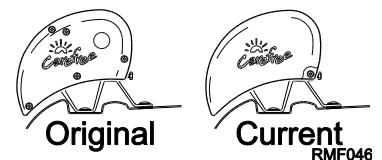

Special Note: Dimensions are provided in centimeters. Conversion formulas are provided below;

$$\text{Inches} = \frac{\text{Centimeters}}{2.54} = \frac{\text{Millimeters}}{25.4}$$

$$\text{Centimeters} = \text{Inches} \times 2.54 \quad \text{Millimeters} = \text{Inches} \times 25.4$$

STANDARD SYSTEM ADJUSTMENTS

MANUAL OVERRIDE

If power to the vehicle is not available, the awning can be safely retracted using the manual override located on the idler (right) end of the case.

NOTE: This procedure cannot be used to extend the awning.

Original Configuration

1. Remove the plug from the right endcap and save.
2. Insert a 3/8" socket drive extension and handle into the square drive hole inside the end cap.
3. Turn the handle clockwise until the awning is retracted.
4. Reinstall the plug

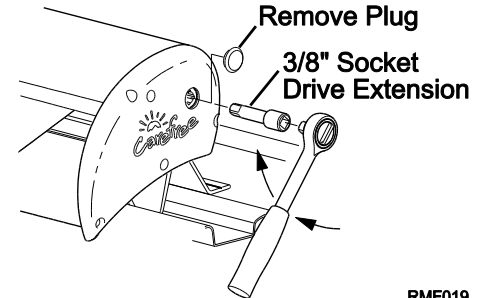

Current Configuration

1. Remove the right outer endcap and save.
2. Insert a 3/8" socket drive extension and handle into the square drive hole inside the inner end cap.
3. Turn the handle clockwise until the awning is retracted.
4. Reinstall the outer cap.

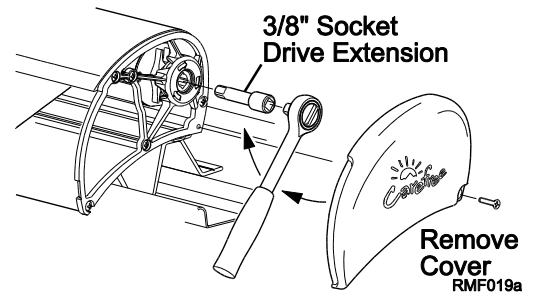

NOTICE After closing the awning with the manual override, the lead rail may move out from the case 1/4" -1/2". This is normal and the awning is secure for travel until power is restored or repairs are completed. Do not attempt to force the lead rail in with the override, serious damage can occur to the awning.

ADJUSTING THE PITCH

The awning opens and closes with a steep pitch. On low profile vans, the leading edge of the awning may hit the top of the sliding door if the door is open while extending or retracting the awning. To prevent this, the lower limit of the pitch can be adjusted upwards.

1. Open the awning to access the adjustment screws located on the arm case knuckles.
2. Have a second person lift up on the lead rail to relieve the pressure on the adjustment screws.
3. Using a 4mm allen wrench, loosen the top screw. Turn the bottom adjustment screw clockwise to raise the lead rail; turn the adjustment screw counterclockwise to lower the lead rail.
4. When the pitch is set at the desired angle, tighten the top screw. Torque to 30 in-lbs.
5. Repeat for each arm. Ensure that the lead rail is parallel with the awning case.

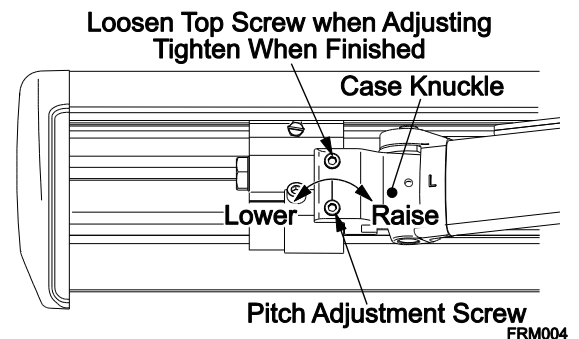

Special Note: The Freedom RM lead rail self-adjusts to accommodate the pitch. No adjustment is required to the lead rail when the pitch is adjusted.

ADJUSTING THE MOTOR LIMITS

The motor limit switches are preset at the factory for best operation of the awning. It may be necessary to reset the switches. The "out" limit switch is used to stop the motor when the awning is fully extended. The "in" limit switch is used to stop the motor when the awning is fully retracted.

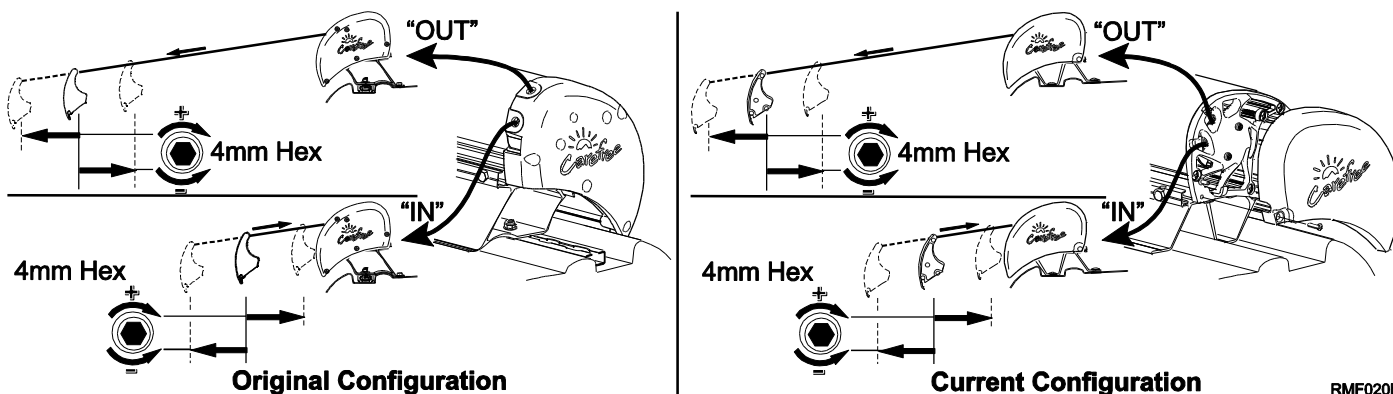

The limit switches are located inside the LH motor endcap. To access the switches:

- For the original configuration remove the plugs from the rear of the endcap.
- For the current configuration remove the outer motor endcap.

Out Limit Switch

The "OUT" limit switch stops the motor when the awning is fully extended.

1. Extend the awning out completely.
2. Confirm that the arms are fully extended. The motor should stop and the fabric should be tight. If the motor continues to run, the fabric will sag; or, if the motor quits before the arms are fully extended, it will be necessary to adjust the "OUT" limit switch.

NOTE: It is best to make the adjustments in increments of a single turn. 3 full turns of the screw equals approximately 2" of fabric extension.

3. If the fabric sags:
 - 3.1. Retract the awning until the fabric is tight then retract an addition 10"-12".
 - 3.2. Using a 4mm Allen wrench turn the "OUT" limit switch COUNTERCLOCKWISE to reduce the time the motor runs.
 - 3.3. Extend to confirm that the adjustment is correct.
 - 3.4. Repeat the procedure until the awning extends correctly.
4. If the arms do not extend completely:
 - 4.1. Retract the awning approximately 10"-12".
 - 4.2. Using a 4mm Allen wrench turn the "OUT" limit switch CLOCKWISE to increase the time the motor runs.
 - 4.3. Extend to confirm that the adjustment is correct.
 - 4.4. Repeat the procedure until the awning extends correctly.

IN Limit Switch

NOTE: The "in" limit switch is not adjusted when the Direct Response system is installed. The system electronics monitors the motor and shuts the motor off when the awning is fully retracted.

If the "in" limit switch is accidentally adjusted, the motor may shut off before the awning is fully closed. If this occurs, turn the "in" adjustment screw CLOCKWISE. It is not necessary that the screw position matches the closed position. The Direct Response electronics controls the closed position.

STANDARD MAINTENANCE

Maintaining a Carefree Awning is easy. Just follow these basic steps:

- Always operate the awning according to the instructions.
- Periodically check that the fasteners are tight. Tighten if necessary.
- Keep the awning fabric and arms clean.

Fabric Care

NOTICE Do not use oil based cleaners or any caustic, granulated, or abrasive type cleaners on your Carefree product.

1. One of the best ways to keep the fabric looking good and to delay the need for deep or vigorous cleanings is to hose fabrics off on a monthly basis with clear water. This practice will help prevent dirt from becoming deeply imbedded in the fabric. In most environments, a thorough cleaning will be needed every two to three years.
2. When it's time for a thorough cleaning, the fabric can be cleaned while still on the awning frame.
 - For Vinyl Fabric – Use a soft brush and warm water with soap.
 - For Acrylic Fabric – Use a stiff brush and warm water with soap.
3. When cleaning the fabric, it is important to observe the following:
 - Always use a natural soap, never detergent.
 - Water should be cold to lukewarm, never more than 100°F.
 - Air-dry only. Never apply heat to the fabric.
 - Always allow the fabric to dry thoroughly before rolling up the awning.

Mildew

Mildew is a fungus growth that looks like dirt. Vinyl coated polyester fabrics are mildew resistant because of a chemical biocide in the vinyl coating. Under ordinary conditions, mildew will not appear. However, in areas where high temperature and humidity are common, mildew can be a problem and required the material to be washed more frequently. Thoroughly rinse the fabric with clean water and allow to air dry completely before rolling up the awning.

Pooling

When water collects on the top of the fabric, this is known as "pooling". This can occur during inclement weather or if a running air conditioner discharges over the awning. The water is dumped when the awning is retracted. It is recommended that if water accumulates on the top; retract the awning in steps (8"-12") to dump the water. This will help prevent the fabric from stretching or distorting.

The effects of wind and rain on an awning are unpredictable. Severe damage to the awning and the vehicle may result. IF WIND OR EXTENDED PERIODS OF RAIN ARE EXPECTED, ROLL UP THE AWNING AND SECURE FOR TRAVEL.

Motor Maintenance

- Check all wiring and connections for wear. Repair when needed.
- Check that the sealant is providing a good seal and no water is accumulating on the wiring.

Arm Noise

After a period of use, the arm knuckle joints may slide together slightly making a squeaking or squealing noise; this is normal and not a reason for concern. To reduce the sound, apply a few drops of multi-purpose oil (3-IN-1^{® 1} or equivalent) on the knuckle joint seams. Operate the awning and repeat 3-4 times to allow the oil to penetrate into the joint.

¹ 3-IN-1[®] is a registered trademark of the WD-40 company.

CANOPY REPLACEMENT (ORIGINAL CONFIGURATION)

This procedure requires two people.

1. Open the awning 18"-24".
2. Disconnect power to the awning.
3. Carefully push the lead rail toward the case so that the arms collapse and the fabric is slack.
4. Hold the lead rail in this position and firmly tie the elbows of the spring arms together. Use a minimum 1/2" rope - do not use bungee cords. When tying the rope, use a non-slip knot such as a square knot or equivalent.

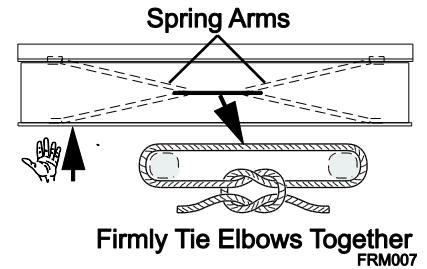

CAUTION

Failure to secure the lead rail as described will allow the spring arms to unexpectedly extend out possibly causing personal injury and damage to the awning.

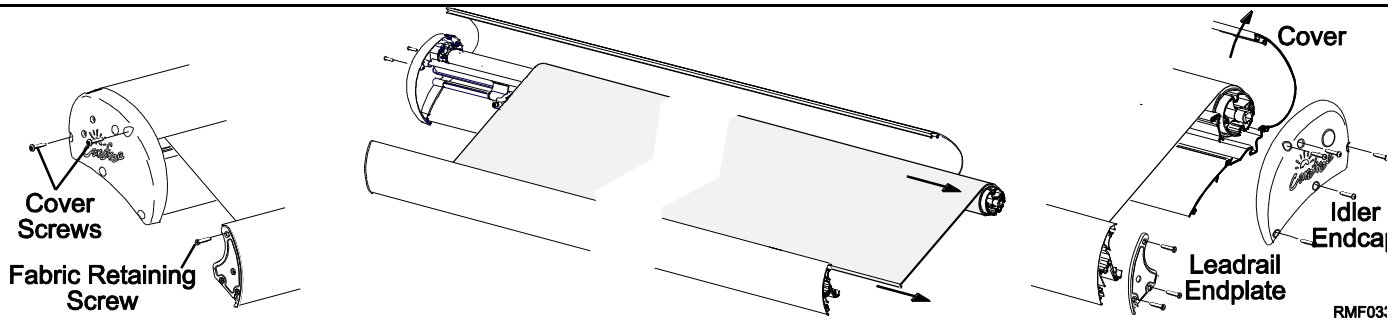

1. On the LH (motor) side:
 - 1.1. Remove the fabric retaining screw from the lead rail endplate.
 - 1.2. Remove the two cover screws. Do not remove the motor or end cap.
2. On the RH (idler) side:
 - 2.1. Remove the lead rail end plate.
 - 2.2. Remove the idler endcap and set aside.
 - 2.3. Rotate the cover back and out of the way.
3. Pull the roller tube out the idler end of the case while pulling the fabric from the lead rail. Pull the roller tube straight, do not allow the roller tube to bend or twist.
4. Note the orientation of the old canopy then unwrap and remove from the roller tube.
5. Unfold the replacement fabric then slide the new fabric onto the roller tube and center.

NOTICE

While the awning fabric is fairly robust, use care not to snag the new fabric while sliding it into the roller tube and lead rail.

Tip: Lightly spraying the slots with a dry silicone lubricant will help the fabric slide into the slots without staining the material.

6. Roll the canopy onto the roller tube leaving enough fabric to reach between the case and the lead rail.
7. Slide the fabric into the lead rail and the roller tube into the case.
8. Align the roller tube with the motor drive and bearing.
9. Support the roller tube and attach the RH end cap while aligning the RH end of the roller tube with the end cap bearing. It is not necessary to close and attach the cover at this time.
10. Open and close the awning to confirm that the fabric rolls and unrolls squarely. Adjust the fabric position in the lead rail as required.
11. Attach the RH lead rail end plate.

NOTE: The top screw secures the fabric in the lead rail. The screw should be positioned to thread into the metal of the lead rail and the edge of the polycord.

12. Attach the fabric retaining screw into the LH lead rail end plate.
13. Close and secure the cover. There are two screws on each end of the awning.
14. After installing the canopy, it may be necessary to adjust the motor limits. Refer to "Adjusting the Motor Limits" on page 3.

CANOPY REPLACEMENT (CURRENT CONFIGURATION)

This procedure requires two people.

1. Open the awning 18"-24".
2. Disconnect power to the awning.
3. Carefully push the lead rail toward the case so that the arms collapse and the fabric is slack.
4. Hold the lead rail in this position and firmly tie the elbows of the spring arms together. Use a minimum 1/2" rope - do not use bungee cords. When tying the rope, use a non-slip knot such as a square knot or equivalent.

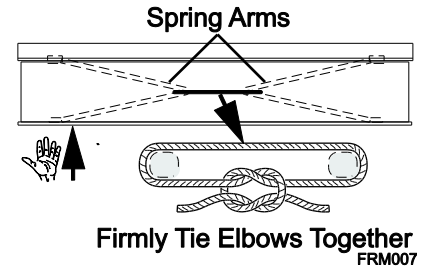

CAUTION

Failure to secure the lead rail as described will

allow the spring arms to unexpectedly extend out possibly causing personal injury and damage to the awning.

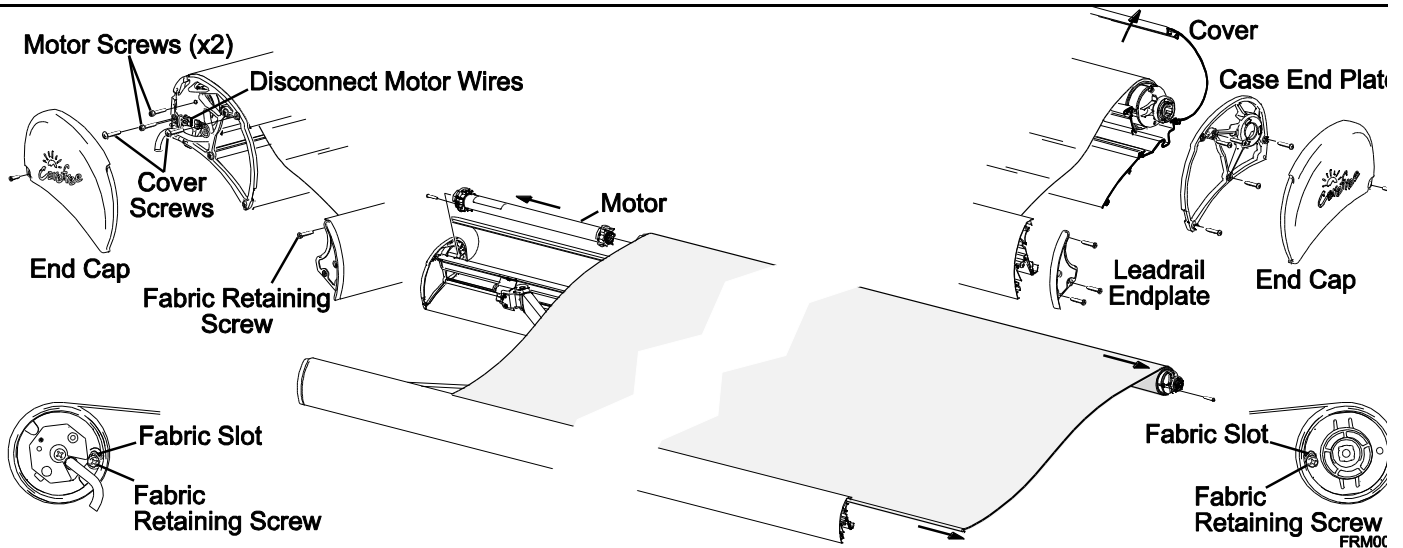

- | | |
|---|---|
| <ol style="list-style-type: none"> 1. On the LH (motor) side: <ol style="list-style-type: none"> 1.1. Remove the fabric retaining screw from the lead rail endplate. 1.2. Remove the outer end cap and set aside. 1.3. Disconnect the motor quick connects. 1.4. Remove the two (2) motor screws and two (2) cover screws from the end plate. | <ol style="list-style-type: none"> 2. On the RH (idler) side: <ol style="list-style-type: none"> 2.1. Remove the lead rail end plate and set aside. 2.2. Remove the outer end cap and set aside. 2.3. Remove the five (5) screws and end plate. Set parts aside. |
|---|---|
3. Rotate the top cover back and out of the way.
 4. Lift the roller tube, fabric and motor up and out of the case.
 5. Remove the fabric retaining screws from the motor bearing and idler end plug.
 6. To prevent accidental damage to the motor, remove the motor from the roller tube and set aside.
 7. Use care and pull the roller tube out the idler end of the case while pulling the fabric from the lead rail.
 8. Note the orientation of the old canopy then unwrap and remove from the roller tube.
 9. Unfold the replacement fabric then slide the new fabric onto the roller tube until the fabric and roller tube are centered.



While the awning fabric is fairly robust, use care not to snag the new fabric while sliding it into the roller tube and lead rail.

Tip: Lightly spraying the slots with a dry silicone lubricant will help the fabric slide into the slot without staining the material.

10. Roll the fabric onto the roller tube leaving enough material to reach between the case and the lead rail.
11. Align the one-way drive and bearing in the roller tube and slide the motor into the roller tube.
12. Secure the fabric on the roller tube with the retaining screws through the bearing and end plug. Note: The screw must be positioned to thread into the metal of the roller tube slot and the edge of the canopy polycord.
13. Slide the fabric into the lead rail and the roller tube into the case.
14. Seat the motor in the LH end plate. Ensure that the motor is oriented with the limit switches pointed toward the access holes in the end plate.
15. On the idler side, position the roller tube end plug into the end plate and attach the end plate to the case. It is not necessary to close the cover at this time.
16. On the motor side, secure the motor to the end plate with the motor screws removed previously.
17. Attach the motor and harness wires (Blue to Brown and Brown to Blue). Fold and tuck the wires and connectors to fit inside the end cap when installed.
18. Restore power to the awning.
19. Open and close the awning to confirm that the fabric rolls and unrolls squarely. Adjust the fabric position in the lead rail as required.
20. Attach the RH lead rail end plate.
NOTE: The top screw of the lead rail end plates secures the fabric in the lead rail. The screw should be positioned to thread into the metal of the lead rail and the edge of the polycord.
21. Attach the fabric retaining screw into the LH lead rail end plate.
22. Close and secure the cover. There are two screws on each end of the awning.
23. After installing the canopy, it may be necessary to adjust the motor limits. Refer to "Adjusting the Motor Limits" on page 3.

SPRING ARM REPLACEMENT

CAUTION The spring arm is under tension to open. Use extreme care to firmly hold the spring arms during assembly and disassembly to avoid any sudden or unexpected movement by the arm. Failure to follow these directions can result in serious personal injury and/or property damage.

NOTE: On replacement arms, the connector assemblies are not included and must be ordered separately if the parts are to be replaced.

The following procedure requires two people.

LEAD RAIL CONNECTOR

The current lead rail connectors are designed to allow the lead rail to close tightly. These are available for all configurations of the Freedom RM.

- If replacing an original style connector, it will be necessary to replace all the lead rail connectors.
- Replacement lead rail connectors are marked LH or RH and must be installed for the correct side.

Removing the Lead Rail Connector

1. Open the awning to the maximum extension or as wide as possible. This will minimize the spring tension in the arms during this procedure.
2. Disconnect power to the awning.
3. Remove the end plate from the lead rail and set aside.
4. On the LH side of the lead rail:
 - 4.1. If installed, disconnect the LED connectors. Wrap or tape the wires from the LED strip out of the way.
 - 4.2. Remove the control module:
 - 4.2.1. If installed, remove the module cover.
 - 4.2.2. Remove the two screws holding the module to the bracket.
 - 4.2.3. Carefully pull the module out and disconnect the 7 module quick connects from the harness.
 - 4.2.4. Mark the location then slide the module bracket out the end of the lead rail.
5. On the lead rail, mark the location of the pivot pin.
6. Loosen the set screw in the lead rail connector.
7. While firmly holding the arm, slide the arm and connector from the lead rail. Allow the arm to extend to its maximum length below the lead rail. Support the unattached end of the arm.
8. Remove the pin and e-ring from the connector.

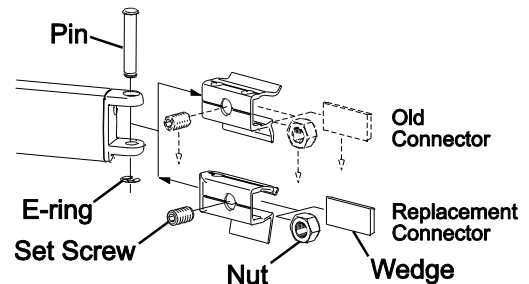
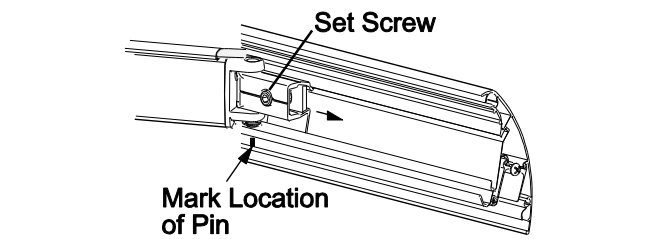
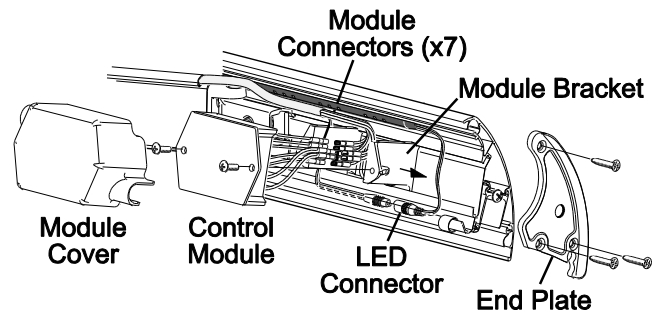

LH shown. Procedures are the same for the RH except as noted in the instructions. FRM001

Attaching the arm to the Lead Rail

1. Move the setscrew, nut and wedge from the old connector to the new connector. Tighten the setscrew until the screw lightly touches the wedge.
2. Attach the connector to the arm using the pin and e-ring removed previously.
3. Slide the connector into the lead rail and align the pivot pin with the location mark made in step 5.
4. Tighten the set screw in the connector. Torque to 50-60 in-lbs.

5. On the LH side of the lead rail:
 - 5.1. Attach the control module:
 - 5.1.1. Slide the module bracket into the lead rail

NOTE: The mounting bracket is held in place by tension from the module attach screws when the module is attached to the bracket.
 - 5.1.2. Attach the module quick connects to the harness. Make sure that the wire colors match.

NOTE: The 16awg RED module wire connects to the BROWN harness wire with RED heatshrink; the 16awg BLACK module wire connects to the BLUE harness wire with BLACK heatshrink.
 - 5.1.3. Mount the module to the bracket with the screws removed previously.
 - 5.1.4. Snap the module cover over the control module.
 - 5.2. If installed, connect the LED connectors.
6. Attach the end plate to the lead rail. Torque screws to 25-30 in-lbs.

REPLACING THE ARM

1. Open the awning to the maximum extension or as wide as possible. This is to minimize the spring tension in the arms during this procedure.
2. Disconnect power.
3. Use a scaffold, ladder or other means to firmly support the lead rail.
4. If replacing the LH (motor side) arm, carefully remove the sensor cable from the wire channel on top of the arm. Use care to not bend, break or compromise the cable.
5. Detach the arm from lead rail. Follow the instructions on page 8 "Removing the Lead Rail Connector".
6. In the case, loosen the large bolt on the side of the knuckle housing until the arm is free. Save the bolt, washer and bushing, these will be reused.
7. Remove the arm and set on a work surface.
8. On a work surface, remove the lead rail connector and the case knuckle from the old arm.
9. Install the lead rail connector onto the new arm.
10. Install the case knuckle onto the new arm. Ensure that the arm stop is positioned as shown. Secure the pin with the M5 setscrew, torque to 15-20 in-lbs.
11. Firmly hold the new arm closed, remove the shipping ties or wrap. Allow the arm to partially open approximately 6"-8" and temporarily tie the arm in that position.
12. If the sensor cable is routed on the replacement arm: Attach a piece of wire channel to the top of each section of the arm using double sided tape. If using new channel, cut each piece slightly shorter than the arm extrusion.
13. Lift the arm up and slide the arm and lead rail connector into the lead rail to the mark made previously.
14. Tighten the M10 connector setscrew. Torque to 50-60 in-lbs.
15. While firmly holding the arm, remove the temporary ties and allow the arm to extend.
16. Position the case knuckle and secure to the knuckle housing using the M10 x75mm bolt, washer and bushing that was removed previously. Torque bolt to 30-35 in-lbs.
17. For the LH arm, route the cable through the wire channel. At the arm joints, arch the cable slightly to avoid binding. Do not twist the cable.

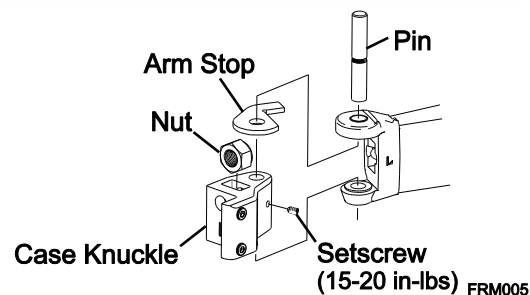
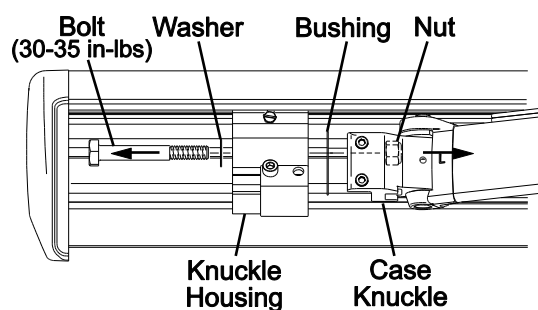

Tip: Use a small tool, such as a flat bladed screwdriver to gently spread open the channel then insert the cable. Do this for the entire length of the channel until the cable is fully inserted.

-
18. For the LH arm, install the control module as described on page 8.
 19. After replacing the arm, it will be necessary to adjust the pitch to align the lead rail and case. See page 2.
 20. Adjust the motor limits as required. See page 3.
 21. Attach the lead rail end plate. Torque screws to 25-30 in-lbs.

MOTOR REPLACEMENT

PRELIMINARY STEPS (ALL CONFIGURATIONS)

1. Disconnect power to the awning.
2. If the awning is extended: Carefully push the lead rail toward the case so that the arms collapse. While holding the lead rail in this position, firmly tie the elbows of the spring arms together. Use a minimum 1/2" rope - do not use bungee cords. When tying the rope, use a non-slip knot such as a square knot or equivalent.
3. If the awning is closed: Firmly brace the lead rail in the closed position. A second person can hold the lead rail steady during the disassembly process.

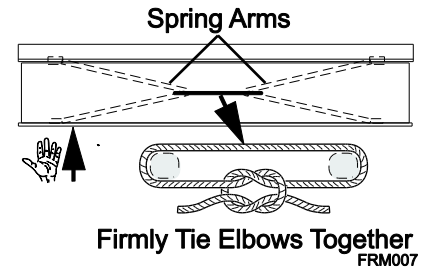

CAUTION If the awning is closed when the motor and end cap screws are removed, the spring arms will try to extend out possibly causing personal injury and damage to the awning. Support the roller tube and allow the awning to open slowly then secure the arms by tying the elbows together as described above.

CAUTION Failure to secure the lead rail as described will allow the spring arms to unexpectedly extend out possibly causing personal injury and damage to the awning.

REPLACING THE MOTOR (ORIGINAL CONFIGURATION)

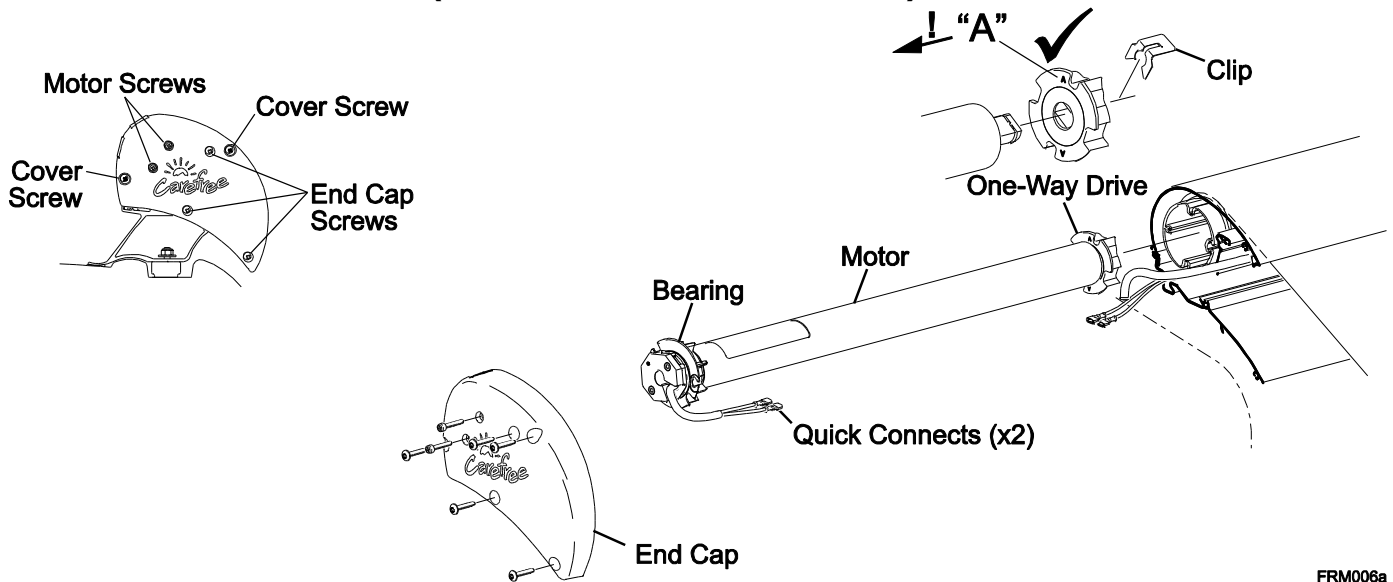

FRM006a

1. From the motor end cap remove the cover screws and end cap screws.
2. Carefully pull the end cap and motor partially out of the roller tube.
3. Disconnect the motor wires from the harness.
4. Remove the motor screws from the end cap and set end cap and screws aside.
5. Pull the motor out of the roller tube and set aside.
6. Attach the one-way drive to the new motor with the "A" pointing toward the motor. Secure with the supplied clip.

NOTICE The one-way drive must be oriented with the "A" facing the motor. If the drive is not oriented correctly, the awning not to operate and the arms will spring out when released.

7. Align the one-way drive with the roller tube and start sliding the new motor into the roller tube.
8. Attach the end cap to the motor with the motor screws removed previously. Ensure that the motor is oriented with the limit switches pointed toward the access holes in the cap.
9. Attach the motor and harness wires, matching the wire colors (Blue to Brown and Brown to Blue). Fold and tuck the wires and connectors to fit inside the end cap.
10. Align the bearing on the motor and slide into the roller tube.
11. Align the screw holes in the end cap and attach to the awning case.
12. While holding the lead rail, carefully remove any roller tube supports and arm ties. Allow the lead rail to extend until the fabric is taut. If the lead rail continues to extend after the fabric is taut, the one way drive was installed backwards. Retie the arms, remove the motor and orient the one way drive as shown.
13. To test:
 - 13.1. Restore power.
 - 13.2. Use the switch to extend and retract the awning.
 - 13.3. Open the awning halfway, shake the lead rail. If the awning extends, the motor wires are reversed. Reverse the motor wire connections.
14. After replacing the motor, it will be necessary to adjust the motor limit switches (page 3).

REPLACING THE MOTOR (CURRENT CONFIGURATION)

Refer to "Preliminary Steps" on page 11 before beginning this procedure.

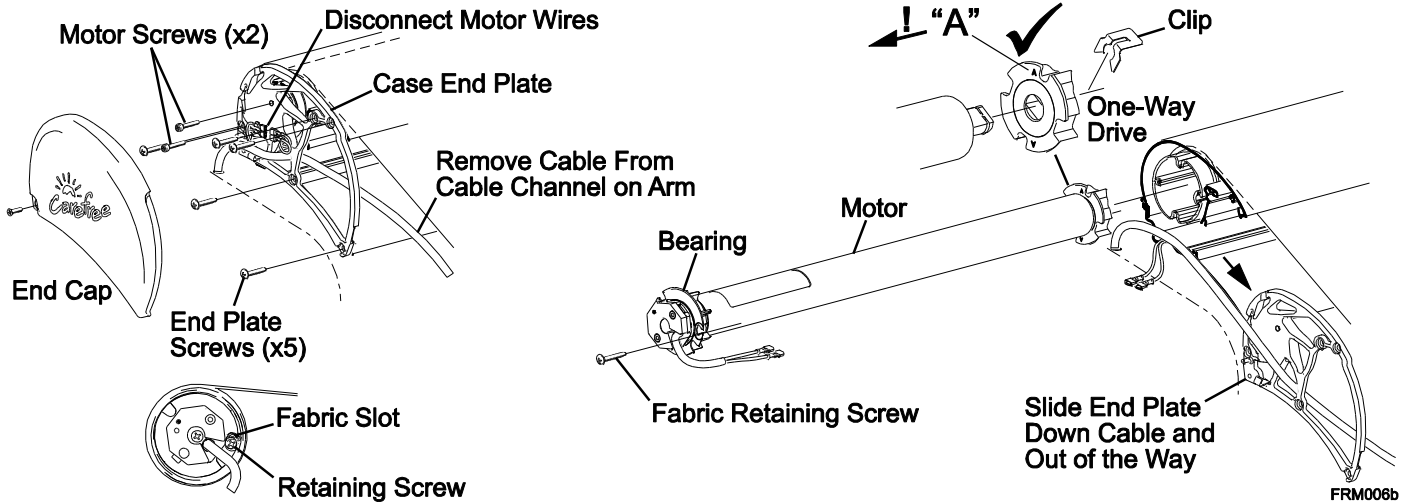

1. Remove the motor end cap and set aside.
2. Disconnect the motor wires from the harness.
3. Remove the harness wire from the cable channel on top of the arm. Allow the harness to hang down.
4. Remove the motor screws (x2) and the end plate screws (5) and set aside.
5. Slide the end plate down along the harness to clear the end of the case.
6. Remove the fabric retaining screw from the motor bearing.
7. Pull the old motor out of the roller tube and set aside.
8. Place the one-way drive onto the new motor with the "A" pointing toward the motor. Secure with the new clip.

NOTICE The one-way drive must be oriented with the "A" facing the motor. If the drive is not oriented correctly, the awning will not operate and the arms will spring out when released.

9. Align the one-way drive with the roller tube and start sliding the new motor into the roller tube.
10. Align the bearing on the motor and slide into the roller tube.
11. Attach the fabric retaining screw through the bearing and into the fabric slot. The screw must be positioned to thread into the metal of the roller tube slot and the edge of the canopy polycord.
12. Attach the end plate to the motor with the motor screws removed previously. Ensure that the motor is oriented with the limit switches pointed toward the access holes in the end plate.
13. Align the screw holes in the end plate and attach to the awning case.
14. Attach the motor and harness wires (Blue to Brown and Brown to Blue). Fold and tuck the wires and connectors to fit inside the end cap.
15. Route the wire harness into the cable channels on top of the arm.
16. While holding the lead rail, carefully remove any roller tube supports and arm ties. Allow the lead rail to extend until the fabric is taut. If the lead rail continues to extend after the fabric is taut, the one way drive was installed backwards. Retie the arms, remove the motor and orient the one way drive as shown.
17. To test:
 - 17.1. Restore power.
 - 17.2. Use the switch to extend and retract the awning.
 - 17.3. Open the awning halfway, shake the lead rail. If the awning extends, the motor wires are reversed. Reverse the motor wire connections.
18. After replacing the motor, it will be necessary to adjust the motor limit switches (page 3).
19. After testing and adjusting the motor limit switches, attach the end cap.

REPLACING THE DIRECT RESPONSE CONTROL MODULE

The control module is located on the LH side (motor side) of the lead rail.

NOTE: The awning will not operate electrically when the module is disconnected.

To Remove:

1. If installed, remove the module cover.
2. Remove the two screws holding the module to the bracket.
3. Carefully pull the module out and disconnect the 7 module quick connects from the harness.

To Install:

1. Attach the module quick connects to the harness. Make sure that the wire colors match.

NOTE: The 16awg RED module wire connects to the BROWN harness wire with RED heatshrink; the 16awg BLACK module wire connects to the BLUE harness wire with BLACK heatshrink.

2. Mount the module to the bracket with the screws removed previously.

NOTE: The mounting bracket is held in place by tension from the module attach screws when the module is attached to the bracket.

3. Snap the module cover over the control module.

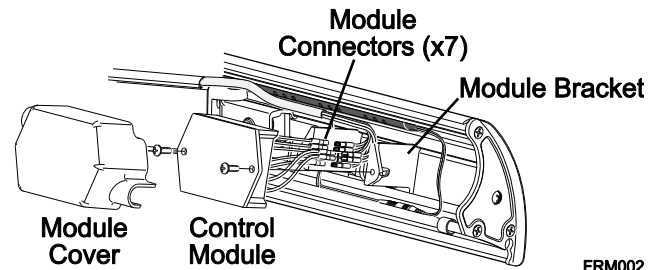

FRM002

WIRING DIAGRAM FREESTYLE RM

WITH DIRECT RESPONSE

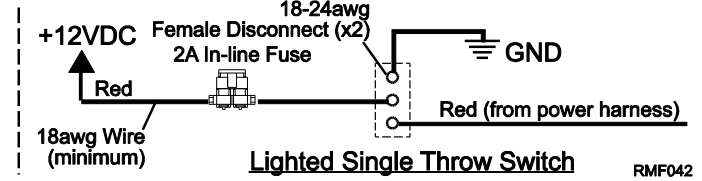
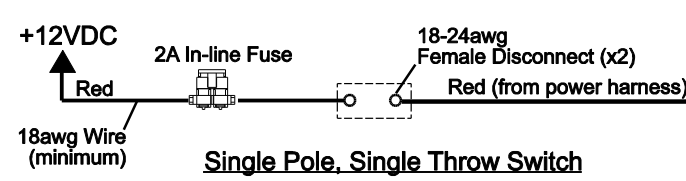
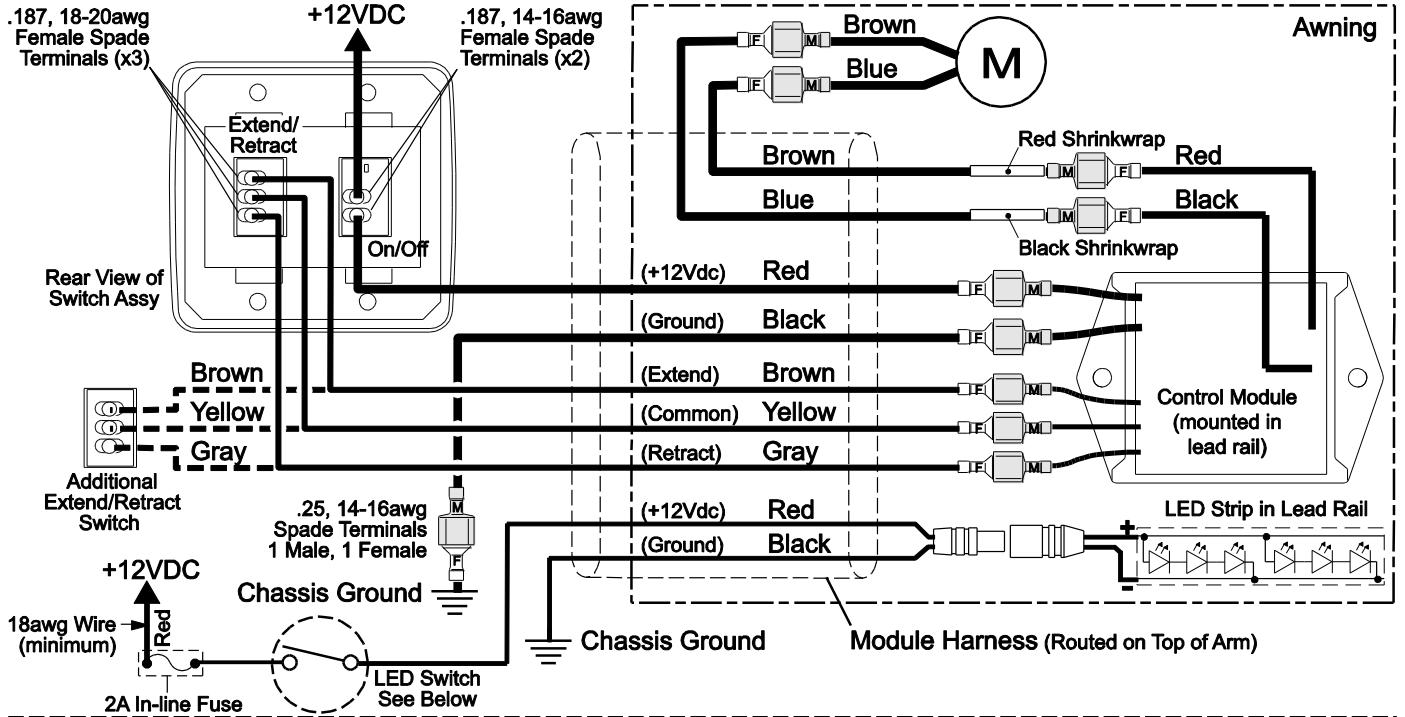

RMF042

WITH DIRECT RESPONSE AND LEAD RAIL POSITION SWITCH

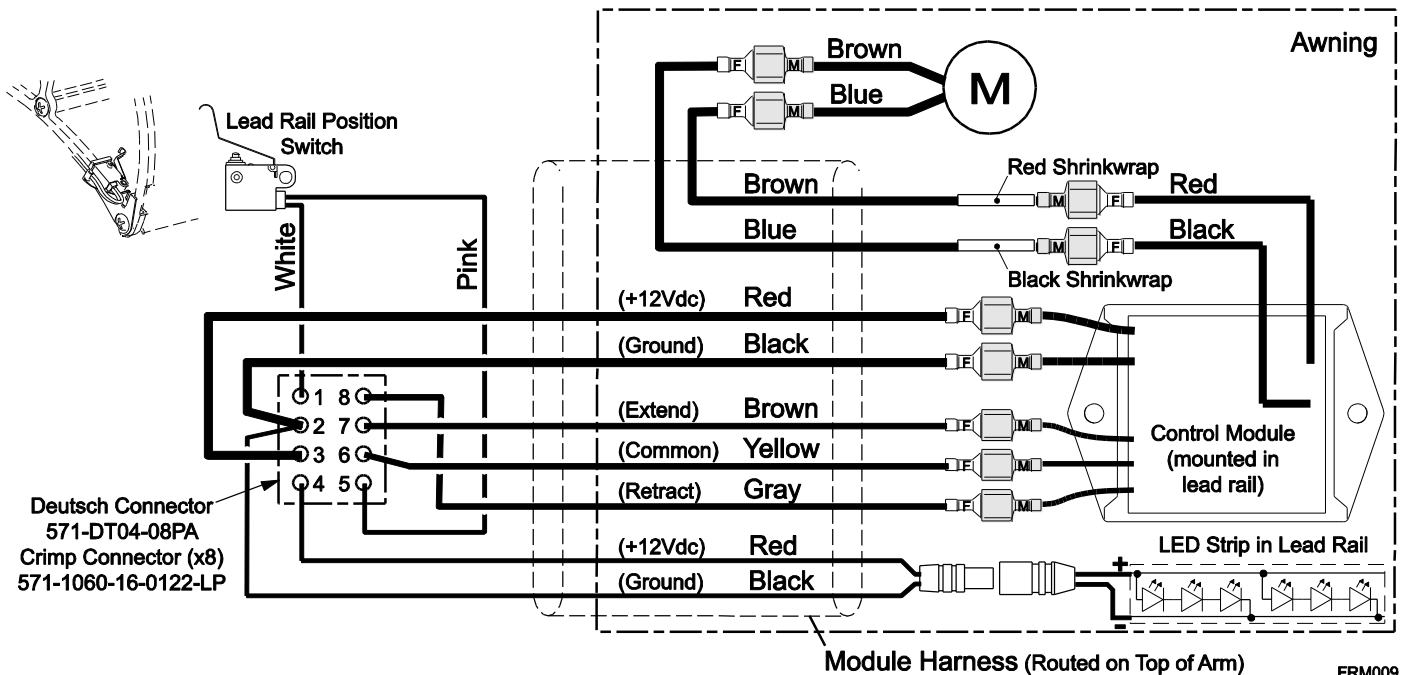

FRM009

PART NUMBER LISTING

PART NUMBER/SERIAL NUMBER LOCATION

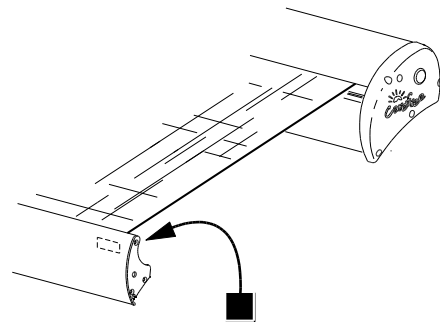

Serial# / Part# Located on the Inside of the Right End of Lead Rail
RMF021

FREESTYLE RM ILLUSTRATED PARTS LIST (ORIGINAL CONFIGURATION)

Original Configuration
(Identified by 5 screws in End Cap)

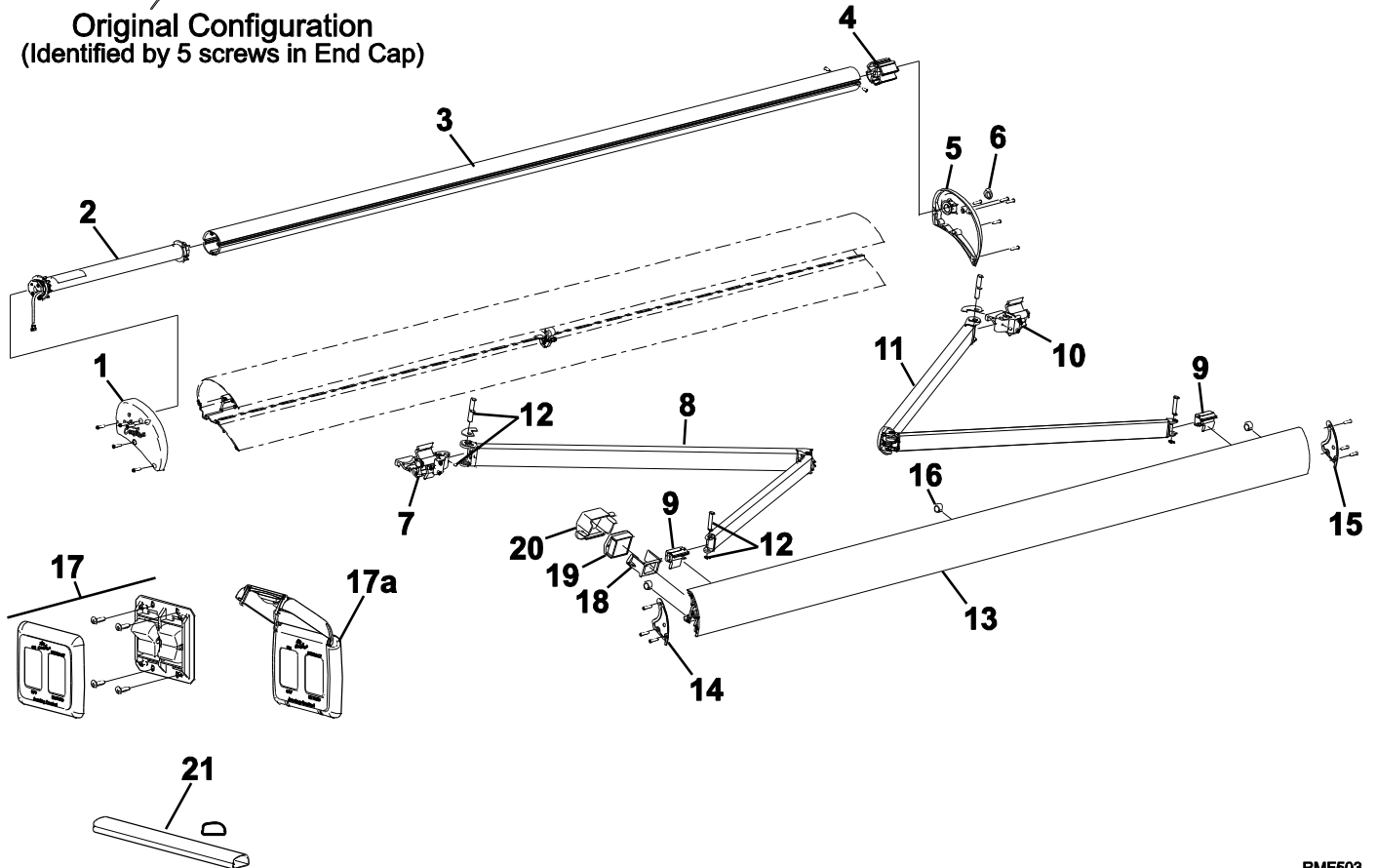

RMF503

Item	Part Number	Description	Notes
1	R037382-005	Endcap, LH, White	
	R037382-006	Endcap, LH, Black	
	R037382-231	Endcap, LH, Satin	
2	R001862	Motor Assembly	2
3	610900-xxx.xx	Roller Tube	
4	R035383-001	End Plug	
5	R001594WHT	Endcap Assy, RH, White	
	R001594BLK	Endcap Assy, RH, Black	
	R001594SAT	Endcap Assy, RH, Satin	
6	R040832-001	Plug, White	
	R040665-002	Plug, Black	
7	R019280-003	Connector Assy, Case, LH	1
8	R012530-TB68L	Spring Arm Assy, LH	Used with 2.44 Meter 1
	R012530-TB76L	Spring Arm Assy, LH	Used with 2.57 Meter 1
	R012530-TB94L	Spring Arm Assy, LH	Used with 3 Meter & Up 1
9	R001872	Connector Kit, Lead Rail	includes 1 LH and 1 RH connector
10	R019280-004	Connector Assy, Case, RH	1
11	R012530-TB68R	Spring Arm Assy, RH	Used with 2.44 Meter 1
	R012530-TB76R	Spring Arm Assy, RH	Used with 2.57 Meter 1
	R012530-TB94R	Spring Arm Assy, RH	Used with 3 Meter & Up 1
12	R001595	Hardware Pack, Arm Attach, 1 Arm	
13	R001819X-aa-xxx	Lead Rail	3
14	R040981-005	Lead Rail End Plate, LH, White	
	R040981-006	Lead Rail End Plate, LH, Black	
	R040981-231	Lead Rail End Plate, LH, Satin	
15	R040981-005	Lead Rail End Plate, RH, White	
	R040981-006	Lead Rail End Plate, RH, Black	
	R040981-231	Lead Rail End Plate, RH, Satin	
16	R001691	Lead Rail Guide Kit	pkg of 4
17	R019468-006	Switch Kit	
17a	SR0115	Covered Bezel Kit	Optional
18	R001679-1	Sensor Bracket Kit, RM	
19	R060686-004	Sensor/Control Module	
20	R041365-001	Module Cover	
21	R040616-206	Cable Channel	43"
22	R060701-003	Harness, Sensor	Not Shown 4
	R060701-004	Harness, Sensor, used w/ 8' only	Not Shown 4

- Notes:
1. Attaching hardware not included with arm assemblies. Order item 12.
 2. Motor assy (item 2) includes motor, bearing and one-way drive. Components not available separately.
 3. For Item 13 (lead rail): X= Color: B=Black, W=White, S=Satin; aa = LED: LI= LED, XX=No LED; xxx= product order length.
 4. Harness (item 22) includes integrated LED harness

For LED replacement parts and service procedures refer to 070013-301 "LED Service Manual for Box Awnings" available on-line at www.carefreeofcolorado.com

FREESTYLE RM ILLUSTRATED PARTS LIST (CURRENT CONFIGURATION)

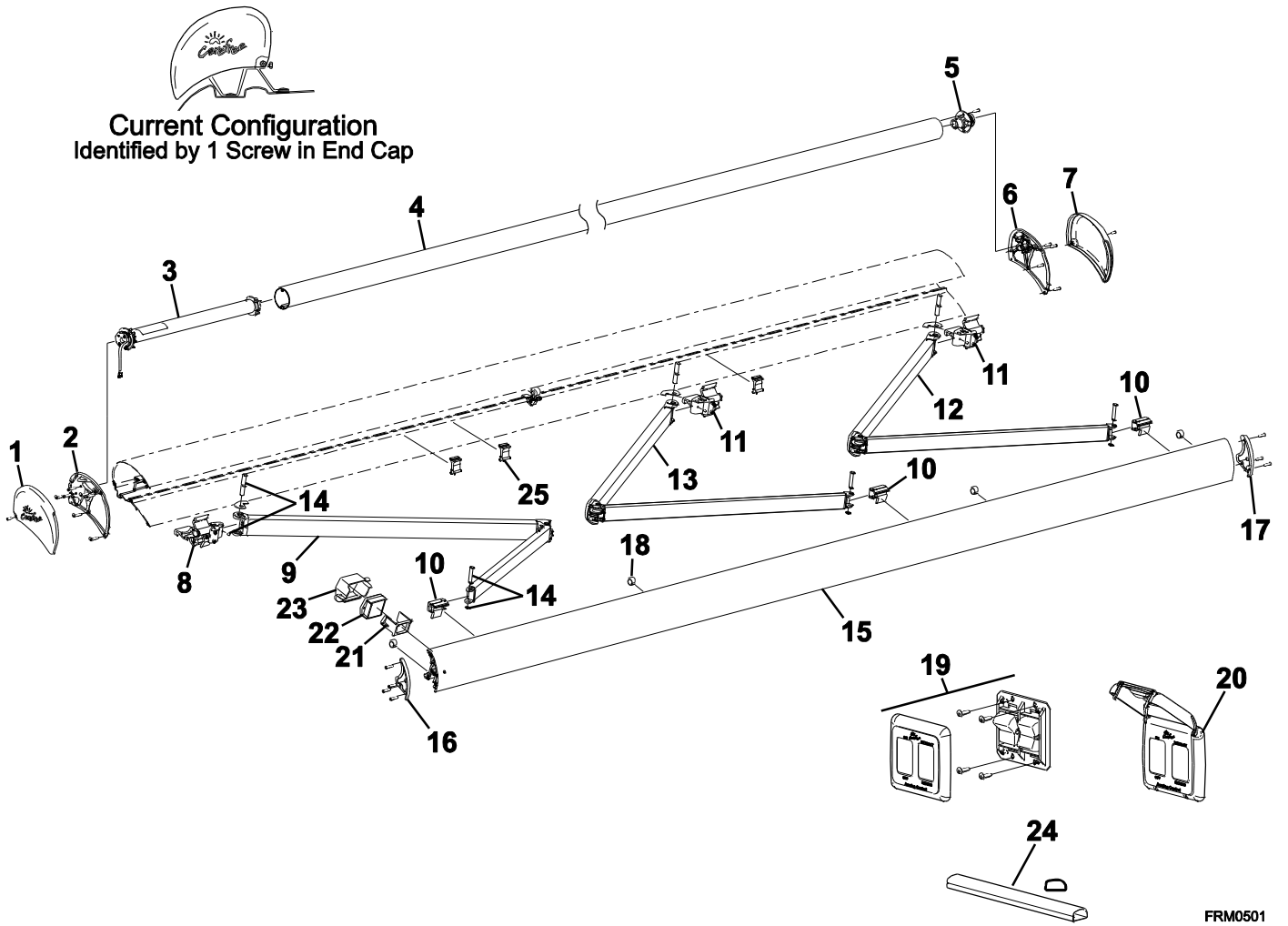

FRM0501

Item	Part Number	Description	Notes
1	R037519-XXX	Endcap, LH	
2	R037517-001	Case Endplate, LH	
3	R001862	Motor Assembly	3
4	610900-xxx.xx	Roller Tube	
5	R001623	End Plug	
6	R037516-001	Case Endplate, RH	
7	R037518-XXX	Endcap Assy, RH	
8	R019280-003	Connector Assy, Case, LH	2
9a	R012530-TB68L	Spring Arm, LH 2.44 Meter	2
9b	R012530-TB76L	Spring Arm, LH 2.57 Meter	Used Thru 05/2017 2
9c	R012530-TB79L	Spring Arm, LH 2.57 Meter	Used 06/2017 & ON 2,7
9d	R012530-TB94L	Spring Arm, LH 3 Meter & Up	2,7
10a	R001872	Connector Kit, Lead Rail	includes 1 LH and 1 RH connector
10b	R001873	Connector Kit, Lead Rail	includes 1 LH and 2 RH connectors
11	R019280-004	Connector Assy, Case, RH	2
12a	R012530-TB68R	Spring Arm, RH 2.44 Meter	2
12b	R012530-TB76R	Spring Arm, RH 2.57 Meter	Used Thru 05/2017 2
12c	R012530-TB79R	Spring Arm, RH 2.57 Meter	Used 06/2017 & ON 2,7
12d	R012530-TB94R	Spring Arm, RH 3 Meter & Up	2,7
13a	R012530-TB79M	Spring Arm, RH Center	2,6,7
13b	R012530-TB94M	Spring Arm, RH Center	2,6,7
14	R001595	Hardware Pack, Arm Attach, 1 Arm	
15	R002014XX-()-xxx	Lead Rail	4
16	R041353-XXX	Lead Rail End Plate, LH	
17	R041352-XXX	Lead Rail End Plate, RH	
18	R001691	Lead Rail Guide Kit	pkg of 4
19	R019468-006	Switch Kit	
20	SR0115	Covered Bezel Kit	Optional
21	R001679-1	Sensor Bracket Kit, RM	
22	R060686-004	Sensor/Control Module	
23	R041365-001	Module Cover	
24	R040616-206	Cable Channel	43"
25	R001970	Arm Bumper	qty: 1
26	R060701-003	Harness, Sensor	Not Shown 5
	R060701-004	Harness, Sensor, used w/ 8' only	Not Shown 5

- Notes:
1. XXX = Color: 001 = Mill; 005 = White; 006 = Black; 231 = Satin; 0JP = Tan; 0JQ = Taupe; 0JR1 = MBWht; 0JS1 = MBBik; 0JU1 = MBSil
 2. Attaching hardware not included with arm assemblies. Order item 14.
 3. Motor assembly (item 3) includes motor, bearing and one-way drive. Components not available separately.
 4. For Item 15 (lead rail): XX= Color; () = LED: L= w/ LED, X=No LED; xxx= product order length.
 5. Harness (item 26) includes integrated LED harness.
 6. The middle spring arm is different than the outer arms. Center arms can be identified by the blue dot located on or near the case connector of the arm. Do not use center arms for replacing outer arms, do not use outer arm to replace the center arm.
 7. Style code JN uses arms items 9c, 12c for all sizes 2.5 meters and up and center arm item 13a for 4.5 and 5 meter.

For LED replacement parts and service procedures refer to 070013-301 "LED Service Manual for Box Awnings" available on-line at www.carefreeofcolorado.com

FREESTYLE RM BRACKET KITS

Bracket kits are ordered separately. Several types are available based on the application installation. Bracket mounting instructions are separate supplements of the installation manual.

BS0012

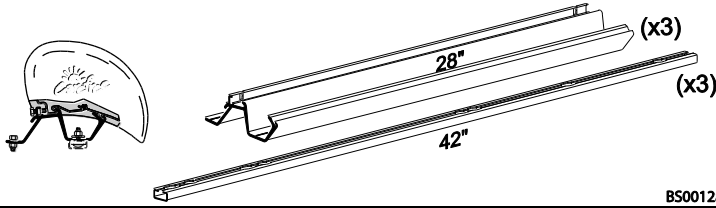

Sprinter
4.5m & 5m

Mill Finish
Bracket and Awning Hardware included
Instruction Supplement: 052570-012

BS0013

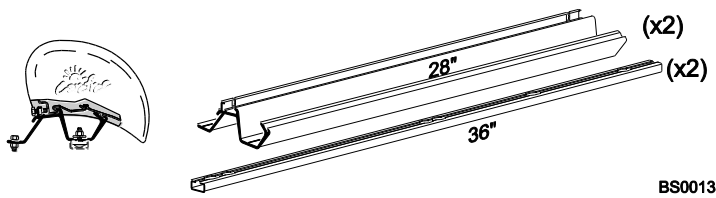

Sprinter
4m and less

Mill Finish
Bracket and Awning Hardware included
Instruction Supplement: 052570-013

BS0014

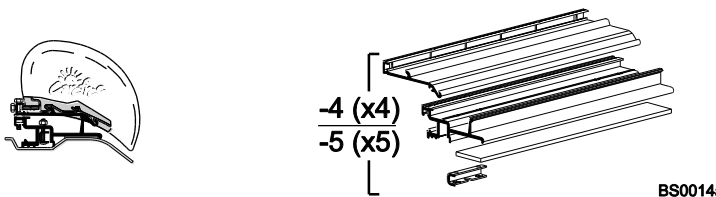

Dodge ProMaster; Fiat Ducato

(-4) 4 Brackets 3.5m
(-5) 5 Brackets 4m

Mill Finish
Bracket and Awning Hardware included
Instruction Supplement: 052570-014

BS0016

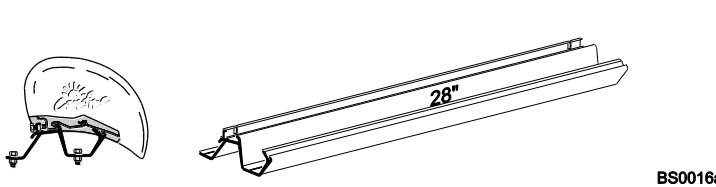

Flat Roof

(-3) 3 Brackets 4m
(-4) 4 Brackets 4.5m & 5m

Mill Finish
Bracket and Awning Hardware included
Instruction Supplement: 052570-016

BS0017

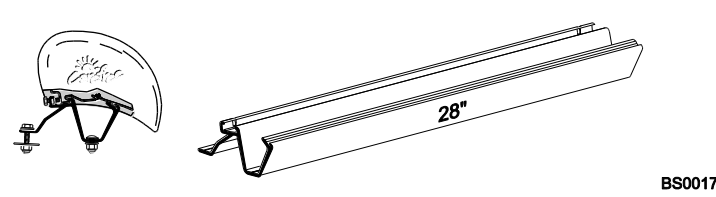

Sprinter – No Rail

(-28-2) 2 Brackets up to 4m

Mill Finish
Bracket and Awning Hardware included
Instruction Supplement: 052570-017

FULL LENGTH BRACKETS

BS0015

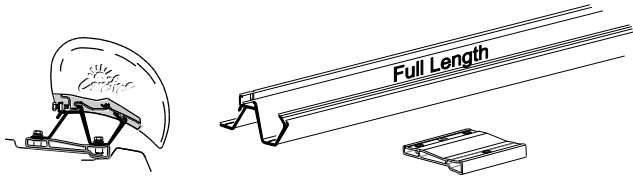

BS0015a

Ford Transit

(-118-XX) Full Length 3m
 (-138-ML) Full Length 3.5m
 (-157-XX) Full Length 4m
 Mill (ML) or Black (JV) Finish
 Bracket and Awning Hardware included
 Instruction Supplement: 052570-015

BS0018

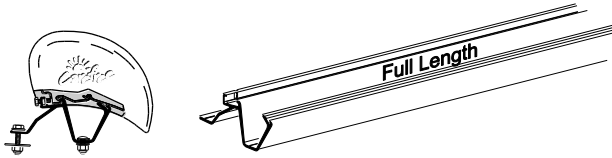

BS0018a

Sprinter – No Rail

(-118-XX) Full Length 3m
 (-157-XX) Full Length 4m
 (-177-XX) Full Length 4.5m
 Mill (ML) or Black (JV) Finish
 Bracket and Awning Hardware included
 Instruction Supplement: 052570-018

BS0019

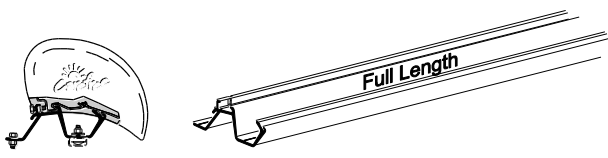

BS0019a

Sprinter used w/ OEM Rail & Flat Roof

(-118-XX) Full Length 3m
 (-157-XX) Full Length 4m
 (-177-XX) Full Length 4.5m
 (-197-XX) Full Length 5m
 Mill (ML) or Black (JV) Finish
 Bracket and Awning Hardware included
 Instruction Supplement: 052570-019

BS0021

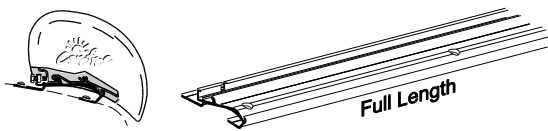

BS0021a

Low Profile RM Mounting Bracket Kit

(-157-ML) Full Length 4m
 (-177-XX) Full Length 4.5m

Mill (ML) or Black (JV) Finish
 Bracket and Awning Hardware included
 Instruction Supplement: 052570-021

BS0023

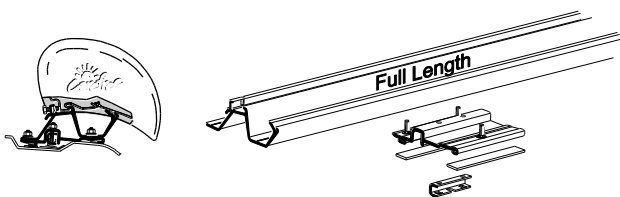

BS0023a

Dodge ProMaster

(-157-XX) Full Length 4m

Mill (ML) or Black (JV) Finish
 Bracket and Awning Hardware included
 Instruction Supplement: 052570-023

