



SERVICE MANUAL

LATITUDE

Product style codes: GW, GX, HB, HN, KT, NW

12V Motorized Lateral Arm Awning w/ Direct Response



Read this manual before servicing or using this product. Failure to follow the instructions and safety precautions in this manual can result in personal injury and/or cause the product to not operate properly.

For LED replacement parts and service procedures refer to 052584-301 “LED Service Manual for Vertical Arms” available on-line at www.carefreeofcolorado.com

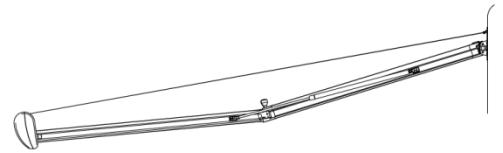

Single Pitch

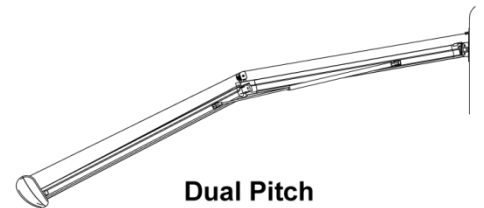
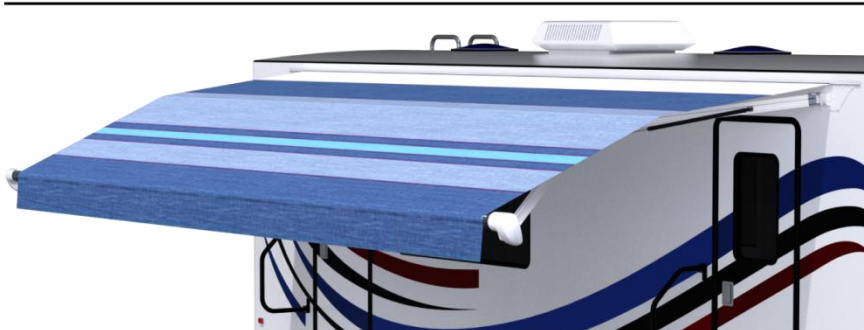

Dual Pitch

FL045

TABLE OF CONTENTS

Standard System Adjustments	1
Adjusting the Arm Position	1
Adjusting the Pitch	1
Canopy Replacement	2
Removing the Head Covers	4
Removing the Covers	4
Attaching the Covers	4
Roller Tube Service	5
Arm Replacement	6
Gas Spring Replacement	7
RH (Motor) Arm Spring	7
LH (Idler) Arm Spring	7
Replacing the Mounting Plate	8
Motor/Gearbox Replacement	9
Sensor/Control Module Replacement	10
Wiring Diagram	11
Switch and Control Module	11
Standard Maintenance	12
Fabric Care	12
Mildew	12
Pooling	12
Hardware Maintenance	12
Motor Maintenance	12
Part Number Listing	13
Part Number/Serial Number Location	13
Single Stage Latitude Illustrated Parts List	13
Dual Stage Latitude Illustrated Parts List	15

PROPRIETARY STATEMENT

The Latitude Awning is a product of Carefree of Colorado, located in Broomfield, Colorado, USA. The information contained in or disclosed in this document is considered proprietary to Carefree of Colorado. Every effort has been made to ensure that the information presented in the document is accurate and complete. However, Carefree of Colorado assumes no liability for errors or for any damages that result from the use of this document.

The information contained in this manual pertains to the current configuration of the models listed on the title page. Earlier model configurations may differ from the information given. Carefree of Colorado reserves the right to cancel, change, alter or add any parts and assemblies, described in this manual, without prior notice.

Carefree of Colorado agrees to allow the reproduction of this document for use with Carefree of Colorado products only. Any other reproduction or translation of this document in whole or part is strictly prohibited without prior written approval from Carefree of Colorado.

SAFETY INFORMATION



This is the safety alert symbol. It is used to alert individuals to potential personal injury hazards. Obey all safety messages that follow this symbol to avoid possible personal injury or death.



Indicates a hazardous situation, which if not avoided, could result in death or serious bodily injury.



Indicates a hazardous situation, which if not avoided, may result in minor or moderate bodily injury.



Indicates a situation that may result in equipment-related damage.

General Safety:



This product can expose you to chemicals including Di-isodecyl phthalate (DIDP), Vinyl Chloride and Formaldehyde, which are known to the state of California to cause cancer or birth defects or other reproductive harm. For more information visit www.P65warnings.ca.gov



Shock Hazard. Always disconnect battery or power source before working on or around the electrical system.



Always wear appropriate safety equipment (i.e. goggles).



Always use appropriate lifting devices and/or helpers when lifting or holding heavy objects.



When using fasteners, do not over tighten. Soft materials such as fiberglass and aluminum can be "stripped out" and lose the ability to grip and hold.

PRODUCT OVERVIEW

The Latitude Awning is a state of the art lateral arm awning. Each unit is equipped with lateral support arms. No vertical arms interfere with coach sidewalls, custom graphics or equipment mounted on the sidewalls.

- Fully retractable and self-storing;
- Available in two configurations: single stage or dual stage;
- The awning motor operates on standard 12VDC (range 10VDC to 14VDC);
- Single touch operation for extend and retract;
- Direct Response is standard;
- LED lights standard, mounted in roller tube;

SPECIFICATIONS

Length	Single Stage	10' 4" – 20' [3.15m – 6.1m]					
	Dual Stage	10' 4" – 18' [3.15m – 5.49m]					
Support:	Lateral Spring Arms						
Motor:	Power: 10VDC–14VDC	Circuit Rating: 15 amp					
(motor is mounted in RH roller tube head)							
Power Source:	Motor and controls are routed and hardwired into the vehicle's 12V system						
Controls:	Carefree Direct Response						
Color:	Hardware:	White or Black					
	Fabric:	Heavy Duty Vinyl with Weatherguard or FLXGuard (refer to sales literature for colors and options)					
Weight:		10' 4"	12'	14'	16'	18'	20'
	Single Stage	45.5 lbs.	48.3 lbs.	51.7 lbs.	55.0 lbs.	58.3 lbs.	61.6 lbs.
	Dual Stage	52.1 lbs.	55.9 lbs.	60.4 lbs.	65.0 lbs.	69.6 lbs.	n/a

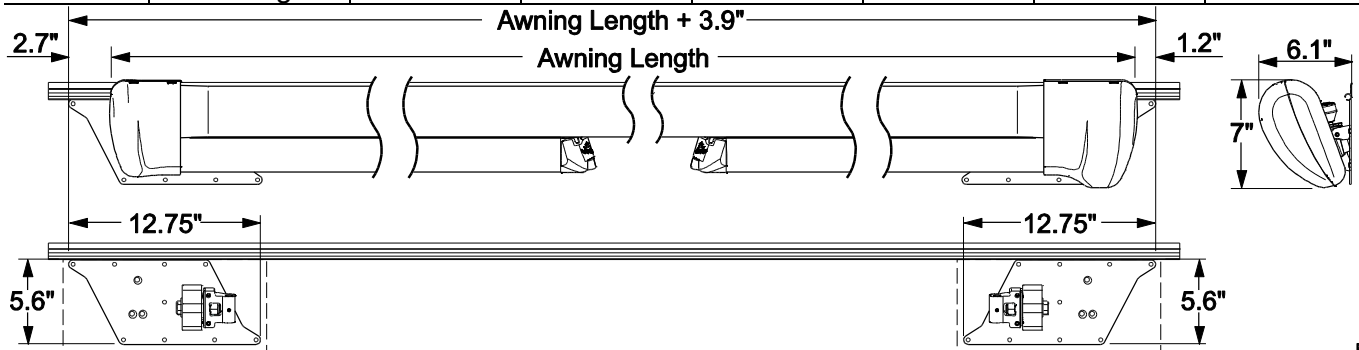

FL002

Original Mounting Plate Configuration

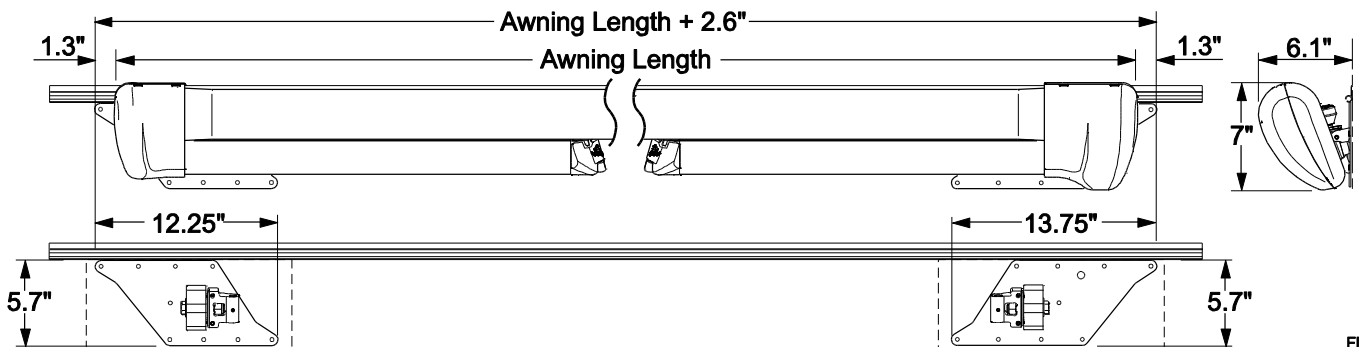

FL002b

Current Mounting Plate Configuration

STANDARD SYSTEM ADJUSTMENTS

ADJUSTING THE ARM POSITION

For the awning to operate and close correctly, the arms must be parallel to the roller tube. If the arm sags, the arm position can be adjusted to bring the arm parallel.

1. Open the awning 2"-3" to access the adjustment screws located on the side of the arm knuckle at the wall.
2. Loosen the upper screw (counterclockwise).
3. Tighten (clockwise) the lower screw to raise the arm elbow.

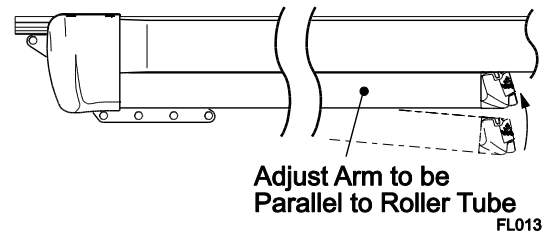
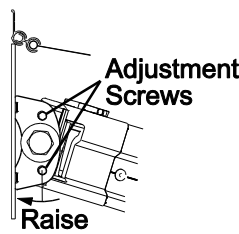

NOTE: Make adjustments in quarter turn increments.

Tip: Lift the arm at the elbow while tightening the lower screw.

1. Repeat steps 2 and 3 until the arm is parallel with the roller tube.
4. Tighten the upper screw.

ADJUSTING THE PITCH

The awning pitch can be adjusted. It is strongly recommended that adjustments be made in small increments to achieve the desired setting.

This procedure works best with 2 people, one person to lift the roller tube to relieve the weight and one person to make the adjustments.

DO NOT USE POWER TOOLS, ALWAYS USE HAND TOOLS TO MAKE ADJUSTMENTS.

1. Open the awning.
2. At the top of the knuckle loosen the locking screw approximately 1/4".

NOTICE The locking screw **MUST** be loosened before adjusting the pitch.

3. To raise the pitch: Turn the lower adjustment screw clockwise.
4. To lower the pitch: Turn the lower adjustment screw counterclockwise.
5. Hand tighten the locking screws until snug when the desired pitch is achieved.

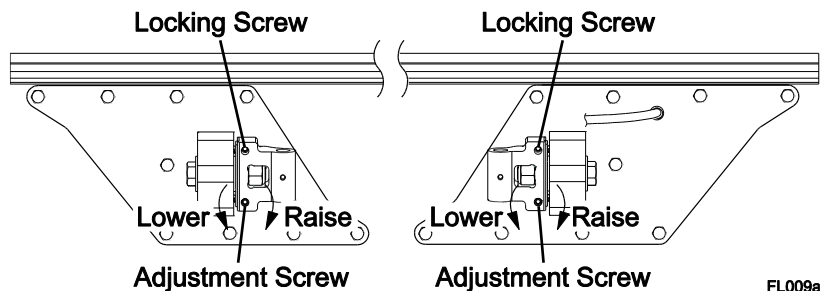

NOTICE Do NOT overtighten the locking screw. Overtightening the screw can cause unnecessary strain and wear on the knuckle.

NOTE: After the initial installation and the awning is opened, the awning may settle. This is normal. Check that the locking screws on the knuckle are snug.

CANOPY REPLACEMENT

1. Extend the awning completely.
2. Firmly tie the elbows of the spring arms together. Use a minimum 1/2" rope - do not use bungee cords. When tying the rope, use a non-slip knot such as a square knot or equivalent.

CAUTION Failure to secure the arms will allow the spring arms to extend possibly causing personal injury and damage to the awning.

3. Over extend the awning to align the fabric slot with the cutout on the idler side. This will cause slack in the fabric.
4. Disconnect Power.

CAUTION When the power is on, the direct response system is active. Movement during this procedure can cause the awning to attempt to close unexpectedly.

5. At the roller tube:
 - 5.1. Remove the fabric retaining screws and plastic washers (quantity of 2 ea).
 - 5.2. On the motor side, remove the split grommet from the roller tube. Carefully pull the wires and connectors out of the tube and disconnect.

6. At the awning rail, cut the LED harness close to the canopy. Clamp the harness going into the vehicle to prevent it from falling in the wall.

7. For canopies with QuickConnect:
 - 7.1. Remove the fabric retaining screws from the QuickConnect (a & b).
 - 7.2. Remove one retaining screw from the awning rail (c).
 - 7.3. Slide the QuickConnect from the awning rail and canopy.

- 7.4. Slide the canopy out of the roller tube.
- 7.5. Slide the new canopy into the roller tube and center.
- 7.6. At the reinforcements in the canopy, secure the fabric to the roller tube with the retaining screws and washers removed previously.
- 7.7. Slip the fabric funnel onto the QuickConnect.
- 7.8. While holding the fabric, simultaneously slide the QuickConnect into the awning rail and over the canopy.

- 7.9. Remove the funnel from the QuickConnect.
- 7.10. Place one (1) #6 x 3/8" screw (c) through the awning rail outside the end of the QuickConnect (not through the QuickConnect).

8. For canopies without QuickConnect:
 - 8.1. Remove the fabric retaining screws from the awning rail.
 - 8.2. Slide the canopy out of the roller tube and awning rail.
 - 8.3. Slide the new canopy into the roller tube and awning rail and center in the roller tube.

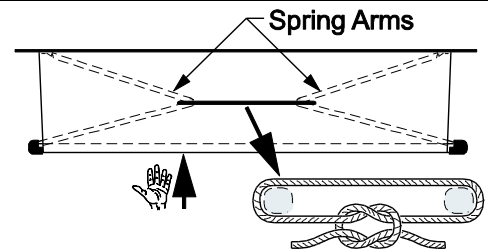

Firmly Tie Elbows Together

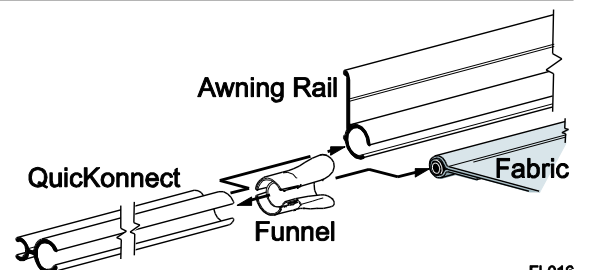
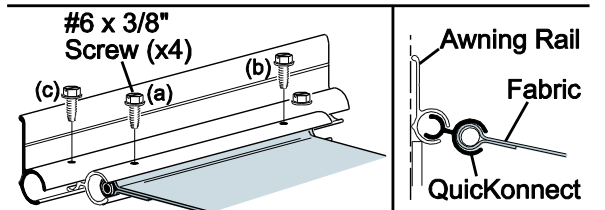
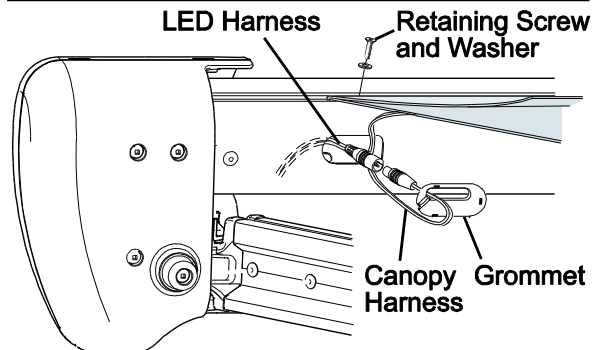
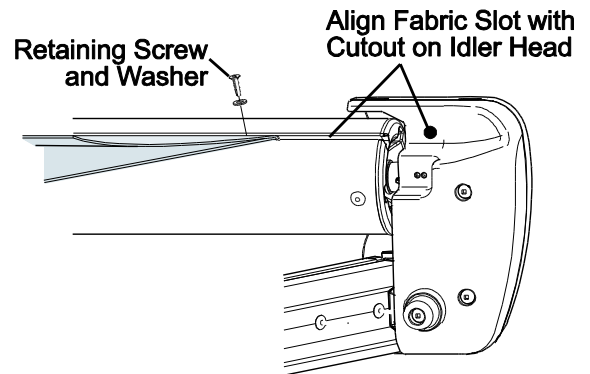

FL016

- 8.4. At the reinforcements in the canopy, secure the fabric to the roller tube with the retaining screws removed previously.
9. While firmly pressing the roller tube, remove the arm ties. Slowly allow the roller tube and arms to extend.
10. Restore power.
11. Retract the awning and check that the canopy is rolling up squarely onto the roller tube. Adjust as necessary.
12. Place one (1) #6 x 3/8" screw (a) through the QuickConnect (or awning rail if the QuickConnect is not used), fabric and polyrod approximately 1" in from the fabric edge
13. On the opposite side, pull the fabric tight then place one (1) #6 x 3/8" screw (b) through the QuickConnect (or awning rail if the QuickConnect is not used), fabric and polyrod approximately 1" in from the fabric edge.
14. Connect the LED harness:
 - 14.1. At the roller tube, connect the canopy harness connector and LED connector. Then carefully push the connectors into the roller tube.
 - 14.2. Place the split grommet over the canopy harness and press the grommet into the hole of the roller tube.
 - 14.3. At the vehicle wall, route the new canopy harness through the wall to the switch.
Tip: Tie the new harness to the old harness that was cut previously. Use the old harness to pull the new harness through the wall to the desired location.
 - 14.4. At the vehicle wall, provide some slack between the canopy and wall. Seal the wall entrance hole and harness with a quality silicone sealant.
 - 14.5. Connect the new harness to the switch. Two (2) .187, 18-24 awg female disconnects are provided if connecting to a switch.
 - 14.6. Alternate method: At the wall, splice the new harness to the existing harness using 24 awg butt connectors. Push the connectors into the vehicle wall. Seal the wall entrance hole and wires with a quality silicone sealant.
NOTE: Be sure to allow enough harness from the canopy to provide some slack for the harness and adequate length for the connectors to be pushed inside the wall before sealing the hole and harness with a quality silicone sealant.

REMOVING THE HEAD COVERS

These instructions are for removing the head covers for service or replacement.

The illustration shows the motor head covers. The instructions apply to both the motor and idler head.

NOTE: *If replacing the covers:* To ensure that the covers properly match up and latch together always replace both the front and rear cover. Replacement kits include both the front and rear covers and attaching hardware.

1. Extend the awning to access the screws in the back cover of the head assembly.
2. Disconnect power.

CAUTION WHEN THE POWER IS ON, THE DIRECT RESPONSE SYSTEM IS ACTIVE. MOVEMENTS DURING THIS PROCEDURE CAN CAUSE THE AWNING TO CLOSE UNEXPECTEDLY.

Removing the Covers

3. Remove the front cover. The cover snaps onto the rear cover. To remove, press the bottom of the rear cover until the front cover releases then rotate and lift the front cover off.
4. For the motor side: Slide the sensor module out of the rear cover. It is not necessary to disconnect the wires. Carefully allow the module to hang down.
5. Remove the screws and bumper from the rear cover and remove the rear cover.

Attaching the Covers

6. Attach the rear cover.
7. For the motor side: Slide the sensor module into the rear cover. Tuck the wires inside the cover.
8. Snap the front cover onto the rear cover. Hang the cover on the top and swing down until it clicks.

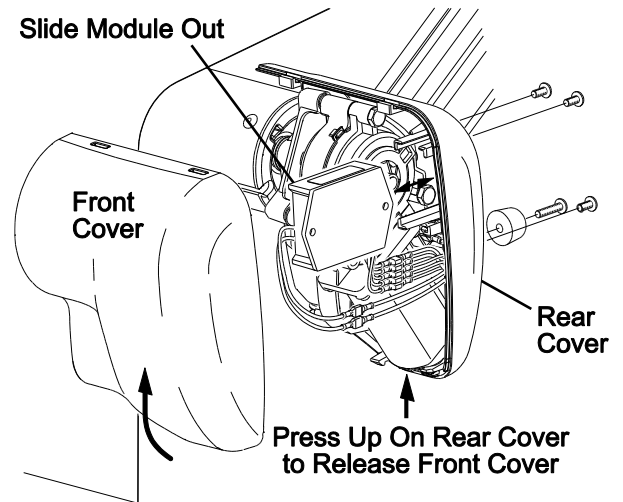

FL029

ROLLER TUBE SERVICE

When service requires removing the Latitude roller tube it is important that the roller tube is correctly attached when reinstalled.

For models made prior to date code 6293 (10-19-2016), the shaft of the roller tube end plug on the motor side has two (2) grooves for attaching e-clips. The e-clips must be placed in the correct grooves for the roller tube attachment.

NOTICE Failure to properly attach the roller tube as shown below can cause unwanted movement of the roller tube causing damage to the awning and making the awning not function correctly.

- **On the idler side:** The e-clip must be placed in the outer groove of the end plug shaft.
 - **On the motor side:** The e-clip must be placed in the inner groove of the end plug shaft.
- NOTE:** On units made after the date code, the shaft has only one (1) groove for the e-clip.
- A replacement roller tube attach kit (R001848) is available to replace lost or damaged attachment hardware.

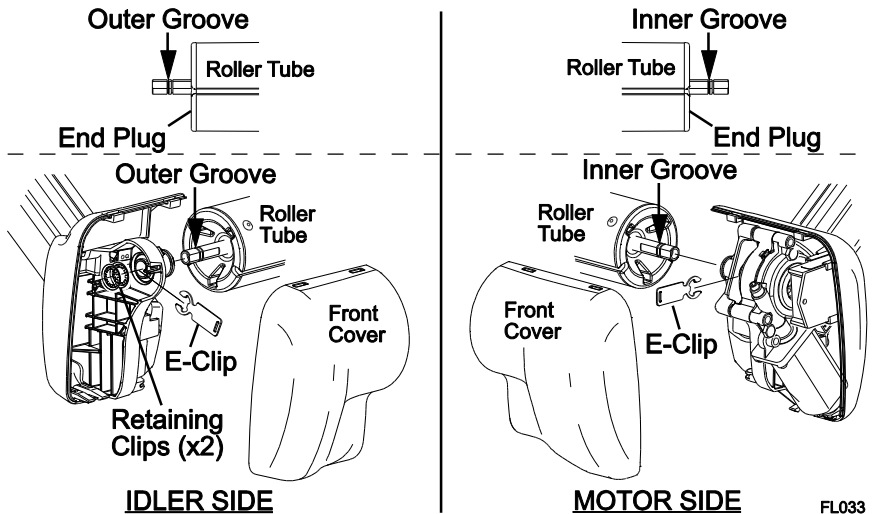

NOTE: Early units used a round e-clip and washers on the idler side. The e-clip with tab shown above replaces the washers and round e-clip. The replacement roller tube attach kit includes the e-clip with tab.

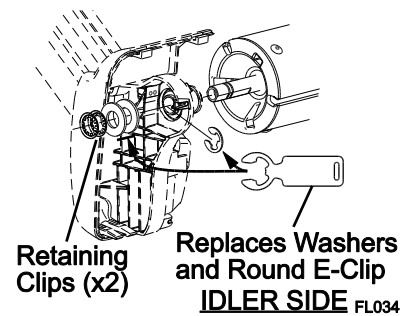

ARM REPLACEMENT

These procedures apply to both the left and right arms. Differences are noted where required.

CAUTION The arm is under tension to open. Use extreme care to firmly hold the arms during assembly and disassembly to avoid any sudden or unexpected movement by the arm. Serious personal injury and/or property damage could occur.

NOTICE When detached, do not allow the roller tube and/or middle rail to drop toward the ground. The twisting motion can damage the opposite arm and awning. Use a scaffold or similar device to support the roller tube and middle rail.

1. Over extend the awning.
2. DISCONNECT POWER.
3. *For Two-Stage Latitude:* Loosen the retaining screw in the glide above the arm elbow. Lift the middle rail off the elbow pin. Provide support for the middle rail.
4. *For the motor side arm:* Carefully pull the control cable from the slot at the top of the arm channels. It is not necessary to disconnect the cable from the motor or wall.
5. At the roller tube:
 - 5.1. Remove the front cover. The cover snaps onto the rear cover. To remove, press the bottom of the rear cover to release the front cover.
 - 5.2. Remove the E-Clip that holds the rotation pin.
 - 5.3. Provide support for the roller tube.
 - 5.4. Firmly hold the arm and remove the rotation pin. Pull the arm out and allow the arm to extend out below the roller tube. Support the arm.
6. At the wall connection:
 - 6.1. Loosen the setscrew and remove the rotation pin.
 - 6.2. Pull the arm from the knuckle and set aside.
7. Using two people firmly hold the new arm assembly and remove the shipping ties. Allow the arm to slowly open to its maximum extension.

CAUTION When the arm is closed, it can open with significant force. Use care when opening.

8. Lift the new arm and attach to the wall knuckle with the rotation pin and set screw removed previously. Ensure that the groove in the pin is in line with the screw hole.
9. At the roller tube:
 - 9.1. Fold the arm as necessary and align the arm with the mounting holes.
 - 9.2. Insert the rotation pin. Ensure that the pin is oriented with the groove down.
 - 9.3. Secure the pin with a new e-clip between the arm knuckle and lower attach bracket ear. Ensure that the clip is in the groove of the pin.
 - 9.4. Attach the front cover.
10. *For the motor side arm:* Carefully press the control cable into the slot at the top of the arm channels. Allow some slack at the joints and elbows to allow the cable to flex when the awning is operated.
11. *For Two-Stage Latitude:* Press the middle rail glide onto the elbow pin. Tighten the securing screw loosened previously.
12. To align the arm. Refer to "Adjusting the Arm Position" on page 1.
13. To adjust the arm pitch. Refer to "Adjusting the Pitch" on page 1.

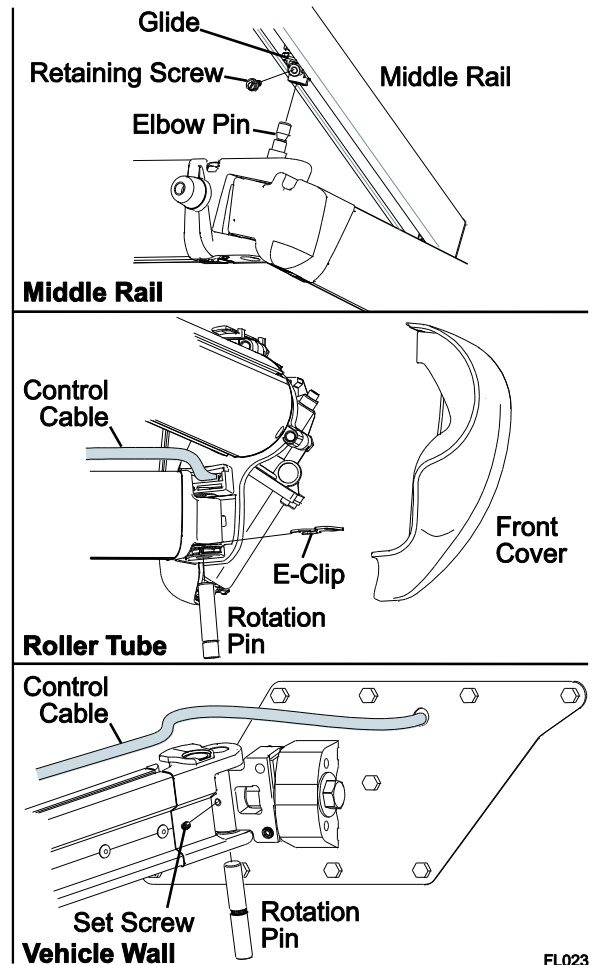

GAS SPRING REPLACEMENT

NOTICE The gas spring clevises must be oriented and installed as shown. Failure to orient the clevises correctly can cause the arms to not function correctly.

NOTICE When detaching the roller tube, do not allow the roller tube to drop toward the ground. The twisting motion can damage the opposite arm. Use a scaffold to support the roller tube.

1. Fully extend the awning.
2. DISCONNECT POWER.

RH (MOTOR) ARM SPRING

1. Remove the front cover. To remove, press the bottom of the rear cover to release the front cover.
2. Remove the E-clip from the roller tube shaft.
3. While firmly holding the arm, slide the motor head off the roller tube shaft. Provide support for the roller tube.
2. Slowly allow the arm to extend fully. Provide support for the end of the arm.
4. Remove the old spring in the following order:
 - 4.1. Unclip the cylinder clevis from the upper bracket.
 - 4.2. Unhook the rod clevis from the lower bracket.
5. Install the new spring in the following order:
 - 5.1. Hook the rod clevis around the lower bracket post.
 - 5.2. Clip the cylinder clevis onto the upper bracket post.
3. Fold the arm to align the roller tube shaft with the motor head. It may be necessary to twist the roller tube to align the flats of the shaft with the motor hole.
4. Secure the roller tube shaft with a new e-clip. The e-clip goes in the **INNER** groove of the roller tube shaft. Refer to page 5.
6. Reattach the front cover.

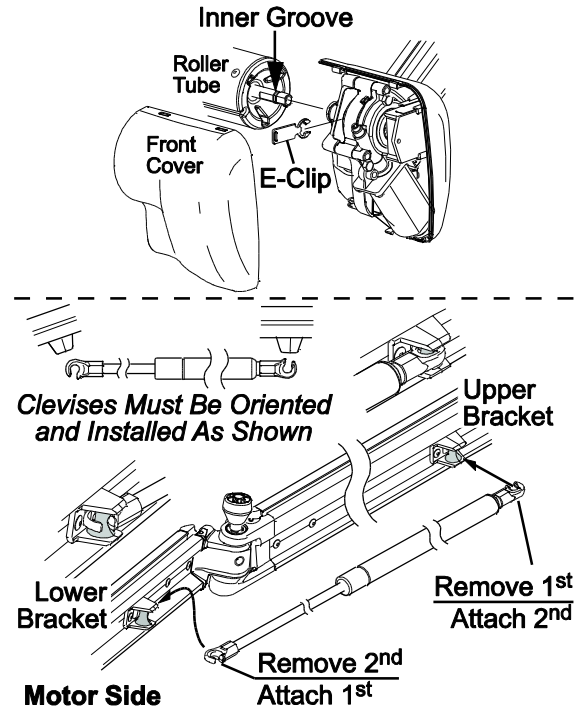

LH (IDLER) ARM SPRING

1. Remove the front cover. To remove, press the bottom of the rear cover to release the front cover.
2. Remove the e-clip and retaining clips (and washers if installed) from the roller tube shaft.
3. While firmly holding the arm, slide the idler head off the roller tube shaft. Provide support for the roller tube.
5. Slowly allow the arm to extend fully. Provide support for the end of the arm.
4. Remove the old spring in the following order:
 - 4.1. Unclip the rod clevis from the lower bracket.
 - 4.2. Unhook the cylinder clevis from the upper bracket.
5. Install the new spring in the following order:
 - 5.1. Hook the cylinder clevis around the upper bracket post.
 - 5.2. Clip the rod clevis onto the lower bracket post.
6. Fold the arm to align the roller tube shaft with the idler head.
6. Secure the roller tube shaft with a new E-clip. The e-clip goes in the **OUTER** groove of the roller tube shaft. Press the retaining clips over the end of the shaft close to the E-clip.
7. Reattach the front cover.

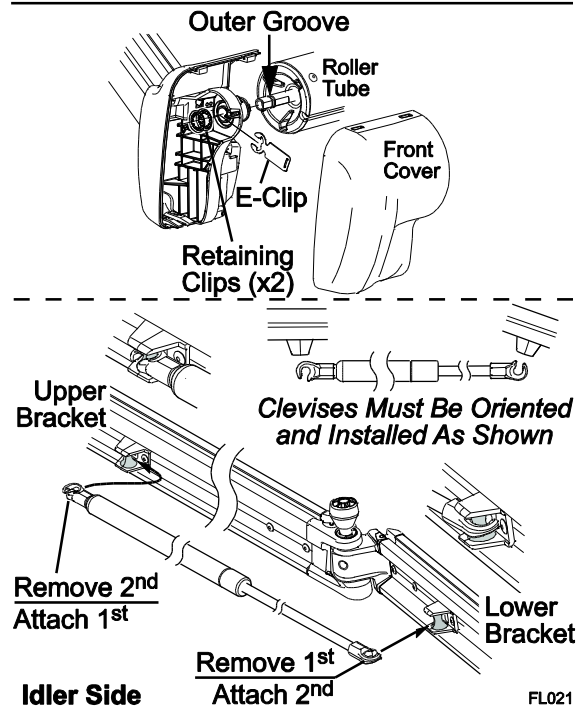

FL021

REPLACING THE MOUNTING PLATE

This procedure requires two people. The illustrations show the RH plate. The procedure is the same for the LH plate.

1. Open the awning 18"-24". This is to allow adequate room for tools and access to the mounting plate.
2. Disconnect power.
3. Do not remove the bottom inner screw and the outer upper screw marked with * in the illustration. Remove the rest of the plate fasteners and set aside.
4. On the side being repaired:
 - 4.1. Collapse the arm. Leave a space between the arm and plate to access the set screw in later steps.
 - 4.2. Securely tie the arm channels together with zip ties. The ties should be close to the head.
5. Have a second person hold and support the roller tube and arm at the arm elbow.
6. For the motor side mounting plate:

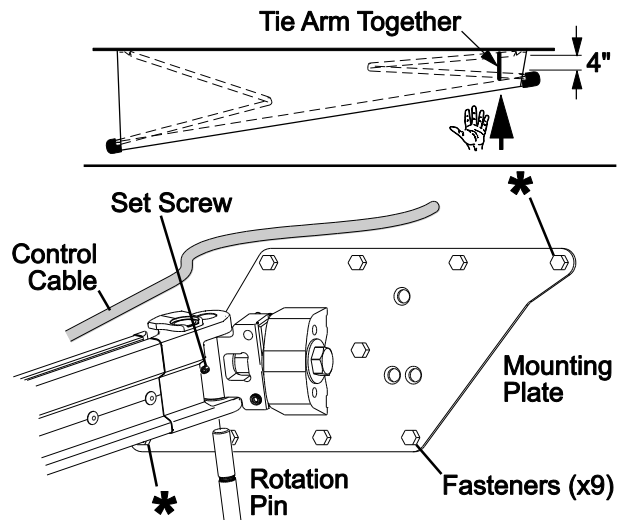

* Remove these fasteners last from old plate; Attach these fasteners first with new plate FL026

NOTICE If replacing the plate on the motor side, use care to not pull or damage the cable.

- 6.1. If the motor cable is routed into the vehicle outside of the plate: Partially remove the wire from the top of the arm channel to provide adequate slack to move the cable out of the way.
- 6.2. If the motor cable and LED harness are routed through a hole in the plate: Pull some slack cable out of the wall and cut the wires. It will be necessary to splice the wires together after the new plate is installed.
7. Remove the two remaining screws in the mounting plate and rotate the arm and plate away from the wall.
8. Loosen the set screw and remove the rotation pin that attaches the arm to the plate. Set plate aside.
9. Attach the arm to the new plate using the rotation pin removed previously. Tighten the set screw to secure the pin.
10. Using the existing mounting holes in the wall, attach the new plate to the wall with a minimum of 2 screws in the bottom inner screw position and the outer upper screw position.
11. Remove the arm ties and allow the roller tube to slowly extend out.

CAUTION Firmly hold the arm while removing the ties. When the arm is closed, it can open with significant force.

12. Install the remaining plate fasteners.
13. For the motor side mounting plate:
 - 13.1. If the motor cable is routed into the vehicle outside of the plate: Insert the motor cable into the groove in the top of the arm channel.
 - 13.2. If the motor cable and LED harness are routed through a hole in the plate: Use appropriate sized butt connectors to attach motor cable and LED wires that were cut previously. Be sure to match the wire colors.

Wire	Wire Gauge	Butt Connector Size
Red and Black LED wires	24awg	22-24 awg
Red and Black Power	16awg	14-16 awg
Brown, Yellow and Gray	20awg	18-22 awg

- 13.3. Push the connectors into the wall and seal the hole with a quality silicone sealant.
14. Check that the arm is properly aligned with the roller tube. Refer to "Adjusting the Arm Position" on page 1.
15. Extend the awning and check the pitch. To adjust the arm pitch refer to "Adjusting the Pitch" on page 1.

MOTOR/GEARBOX REPLACEMENT

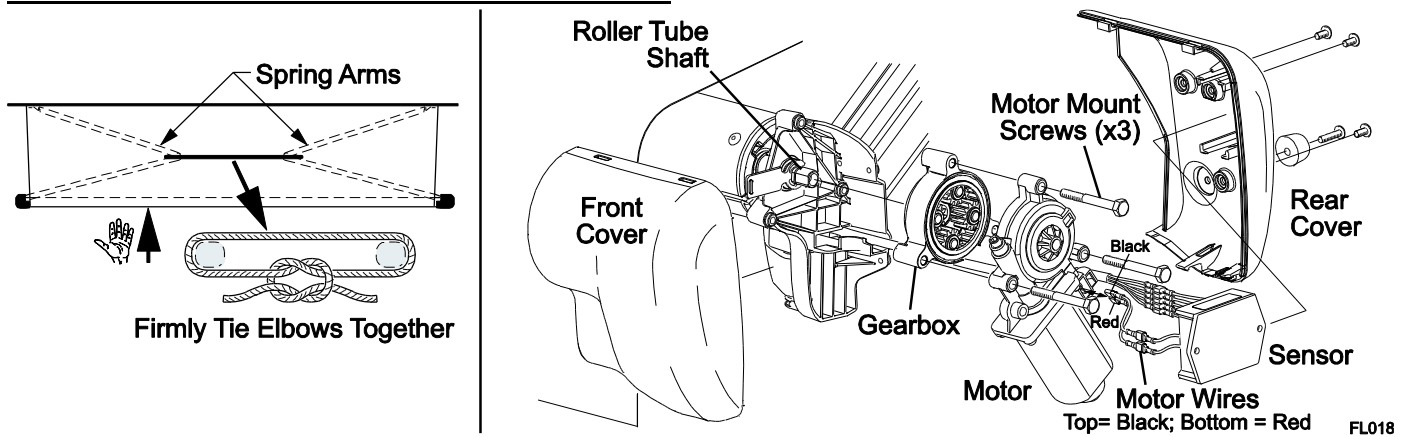

1. Extend the awning a minimum of 18" to access the screws in the back cover of the motor side head assembly.
2. Disconnect Power.

CAUTION When the power is on, the Direct Response system is active. Movements during this procedure can cause the awning to attempt to close unexpectedly.

3. Press the roller tube toward the vehicle until the fabric becomes slack.
4. Firmly tie the elbows of the spring arms together. Use a minimum 1/2" rope - do not use bungee cords. When tying the rope, use a non-slip knot such as a square knot or equivalent.

CAUTION Failure to secure the arms as described will allow the spring arms to extend when the motor is detached possibly causing personal injury and damage to the awning.

5. Remove the front cover. The cover snaps onto the rear cover. To remove, press the bottom of the rear cover until the front cover releases then lift the front cover off. Set part aside.
6. Slide the sensor module out of the rear case. Disconnect the wires attached to the motor and allow the sensor to hang down on the remaining wires.
7. Remove the screws and bumper from the rear cover and remove the rear cover. Set parts aside.
8. Remove the motor mounting screws and set aside.
9. Slide the motor and gearbox off of the roller tube shaft. Separate the motor and gearbox.
10. Align the gearbox and new motor and insert the motor mount screws through both.
11. Align the gearbox with the roller tube shaft and attach the gearbox and motor with the mounting screws.

NOTE: It may be necessary to twist the roller tube to align the flats of the shaft with the hole in the gearbox.

12. Attach the motor wires from the module to the motor. Black goes to the top connection, Red goes to the bottom connection.
13. Attach the rear cover.
14. Slide the sensor module into the rear cover.
15. Snap the front cover onto the rear cover. Hang the cover on the top and swing down until it clicks.
16. Hold the roller tube and remove the ties around the arms. Allow the roller tube to extend out slowly.
17. Restore power and test.

SENSOR/CONTROL MODULE REPLACEMENT

This procedure may be done with the awning open or closed.

1. Disconnect power to the awning.
2. Remove the front cover. The cover snaps onto the rear cover. To remove, press the bottom of the rear cover until the front cover releases then lift the front cover off. Set part aside.
3. Slide the sensor module out of the rear case. Disconnect the wires to the module.
4. Connect the motor and cable wires to the new module. Make sure to match the wire colors.
5. Slide the new module into the rear cover and tuck the wires.
6. Snap the front cover onto the rear cover. Hang the cover on the top and swing down until it clicks.
7. Restore power and test.

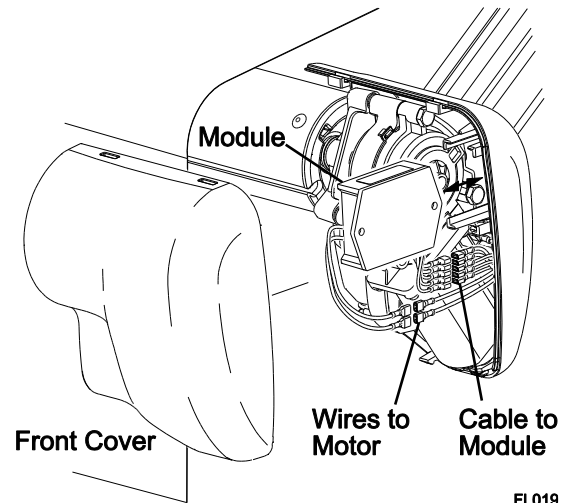

WIRING DIAGRAM

Switch and Control Module

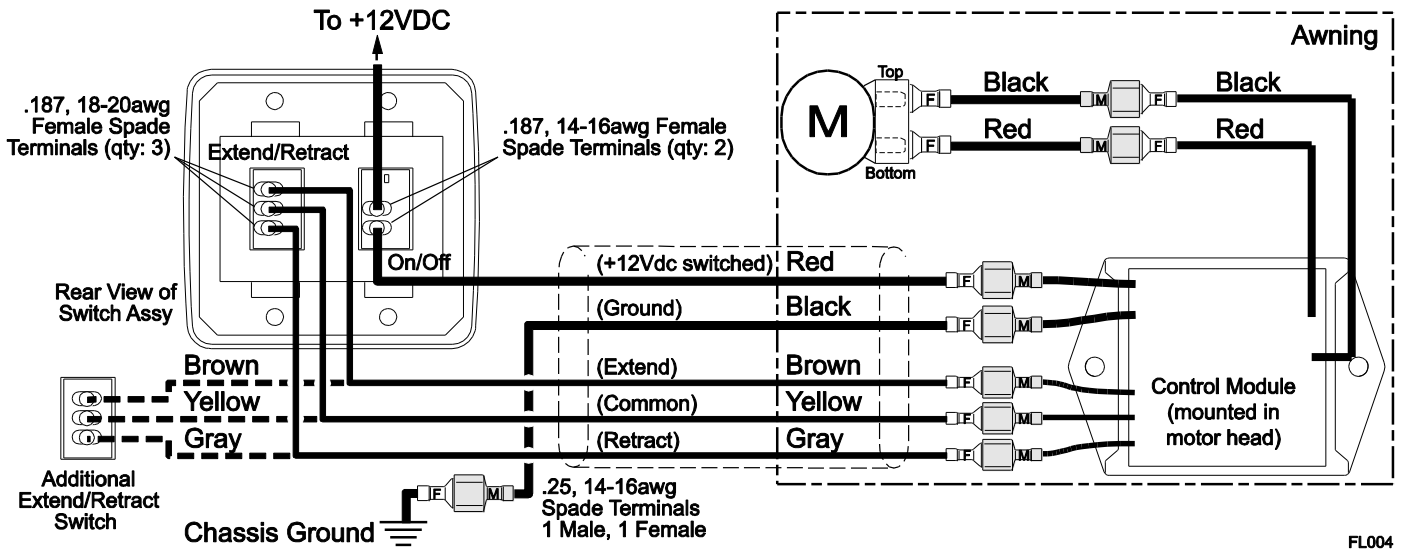

STANDARD MAINTENANCE

Maintaining a Carefree Awning is easy. Just follow these basic steps:

- Always operate the awning according to the instructions.
- Periodically check that the fasteners are tight. Tighten if necessary.
- Keep the awning fabric and arms clean.

FABRIC CARE

NOTICE Do not use oil based cleaners or any caustic, granulated, or abrasive type cleaners on your Carefree product.

1. One of the best ways to keep the fabric looking good and to delay the need for deep or vigorous cleanings is to hose fabrics off on a monthly basis with clear water. This practice will help prevent dirt from becoming deeply imbedded in the fabric. In most environments, a thorough cleaning will be needed every two to three years.
16. When it's time for a thorough cleaning, the fabric can be cleaned while still on the awning frame.
 - For Vinyl Fabric – Use a soft brush and warm water with soap.
 - For Acrylic Fabric – Use a stiff brush and warm water with soap.
17. When cleaning the fabric, it is important to observe the following:
 - Always use a natural soap, never detergent.
 - Water should be cold to lukewarm, never more than 100°F.
 - Air-dry only. Never apply heat to the fabric.
 - Always allow the fabric to dry thoroughly before rolling up the awning.

Mildew

Mildew is a fungus growth that looks like dirt. Vinyl coated polyester fabrics are mildew resistant because of a chemical biocide in the vinyl coating. Under ordinary conditions, mildew will not appear. However, in areas where high temperature and humidity are common, mildew can be a problem and required the material to be washed more frequently. Thoroughly rinse the fabric with clean water and allow to air dry completely before rolling up the awning.

Pooling

When water collects on the top of the fabric, this is known as "pooling". This can occur during inclement weather or if a running air conditioner discharges over the awning. The water is dumped when the awning is retracted. It is recommended that if water accumulates on the top; retract the awning in steps (8"-12") to dump the water. This will help prevent the fabric from stretching or distorting.

The effects of wind and rain on an awning are unpredictable. Severe damage to the awning and the vehicle may result. IF WIND OR EXTENDED PERIODS OF RAIN ARE EXPECTED, ROLL UP THE AWNING AND SECURE FOR TRAVEL.

Hardware Maintenance

- Replace any parts that become damaged.
- Periodically check all mounting hardware, screws, lags, etc., and re-tighten when necessary.

MOTOR MAINTENANCE

- Check all wiring and connections for wear. Repair when needed.
- Check that the sealant is providing a good seal and no water is accumulating on the wiring.

PART NUMBER LISTING

PART NUMBER/SERIAL NUMBER LOCATION

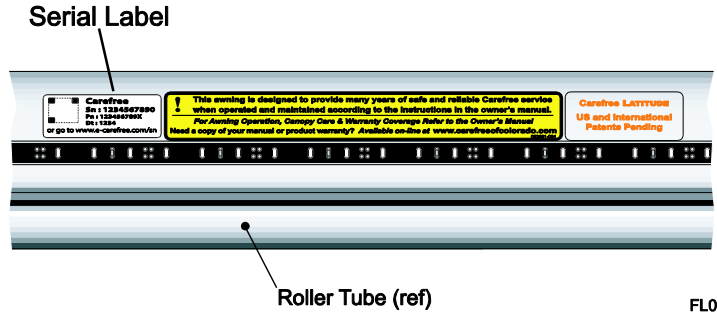
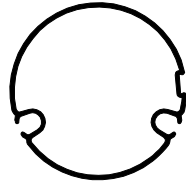

FL012

SINGLE STAGE LATITUDE ILLUSTRATED PARTS LIST

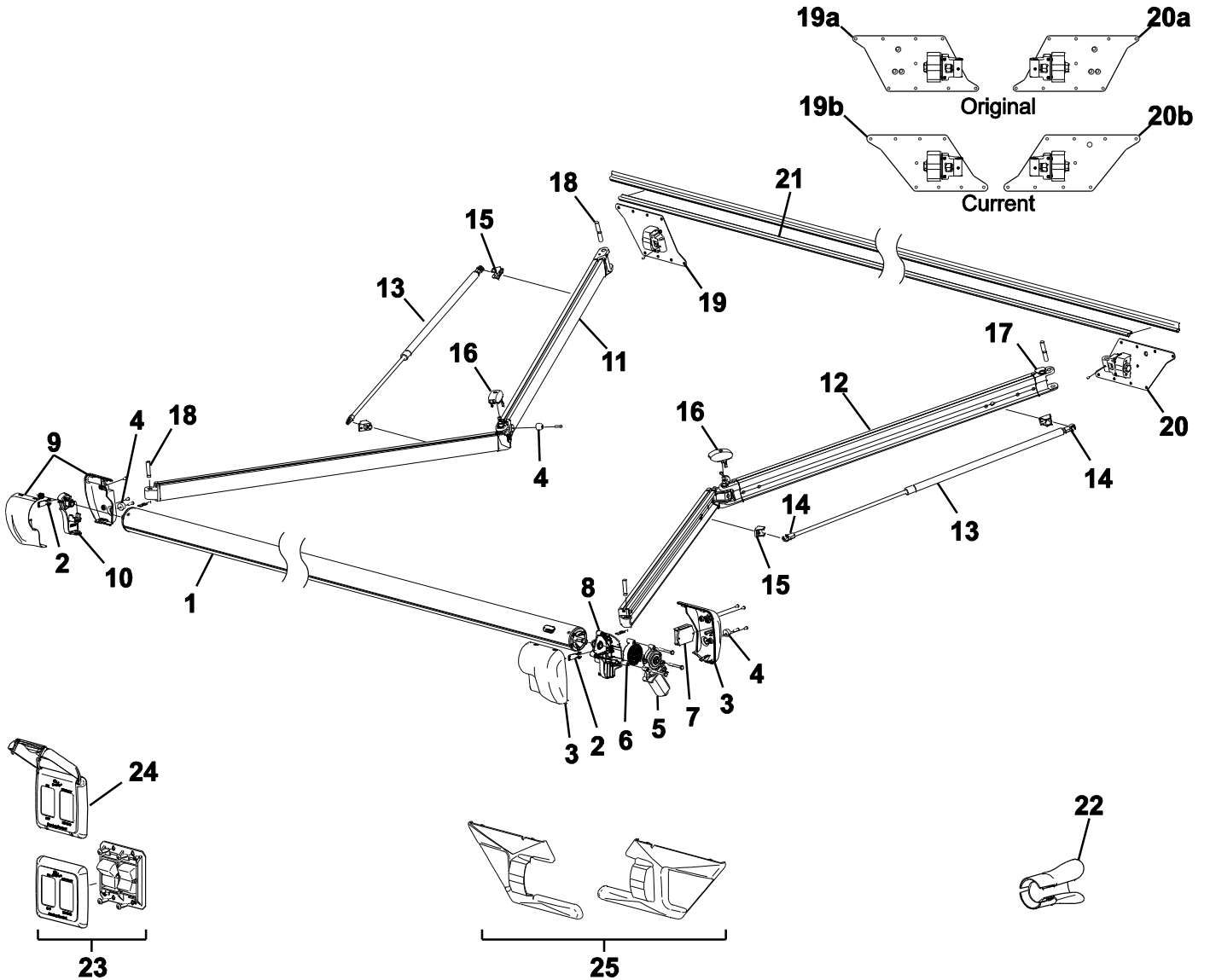

FL501

Item	Part Number	Description	Notes
1	R001782-xxx	Roller Tube Assy	2
2	R001848	Roller Tube Attach Kit	5
3	R001783-00X	Cover Kit, Motor	
4	R001798	Bumper	
5	R001784	Motor Assy	
6	R001810	Gearbox Assy	
7	R060686-003	Sensor/Control Module, Direct Response	
8	R012659-001	Motor Bracket	
9	R001785-00X	Cover Kit, Idler	
10	R012660-001	Idler Bracket	
11	R001786-10X	Arm Assy, LH, Single Stage	3
12	R001787-00X	Arm Assy, RH, Single Stage	3
13	R001788	Gas Spring, Latitude Single Stage	
14	R040905-001	Hook, Gas Spring	pkg of 2
15	R001789	Support, Gas Spring	pkg of 2
16	R001823	Barrel, used on Single Stage Only	pkg of 2
17	R001790	Cable Retainer	used on Single Stage Only
18	R001791	Arm Attach Kit	One Arm
19a	R019376-20X	Mounting Bracket Assy, LH	Original
19b	R019397-00X	Mounting Bracket Assy, LH	Current
20a	R019376-30X	Mounting Bracket Assy, RH	Original
20b	R019397-10X	Mounting Bracket Assy, RH	Current
21	R001792-xxx	QuicKconnect	
22	R040925-001	Canopy Funnel	
23	R019468-006	Switch Kit	
24	SR0115	Bezel Cover Kit	
25	R001977	Mounting Bracket Cover Kit	Black
	R001978	Mounting Bracket Cover Kit	White
26	R060703-00X	Cable Assy, 5 Conductor	not shown
27		Canopy Only	Refer to Canopy Order Form
28	R019886-005	Screw Pack, 1/4-20 x 1" Self-drilling, White	not shown
	R019886-006	Screw Pack, 1/4-20 x 1" Self-drilling, Black	not shown
29	R019886-007	Screw Pack, 1/4 x 2" Lag, White	not shown
	R019886-008	Screw Pack, 1/4 x 2" Lag, Black	not shown

- Notes:**
- 0X = Color = 05 – White, 06 – Black; xx = Length
 - Roller tube (item 1) is complete with end bushings, LED strip
 - Arm Assemblies (items 11, 12) includes items 4, 13, 14, 15 and 16. Does not include attaching pins. For attach pins order item 18 (1 kit per arm).
 - Original and current mounting brackets are not interchangeable. Replacement brackets must match the existing brackets. Original brackets can be identified by the 3 hole pattern beside the knuckle.
 - The roller tube e-clips w/ tab replace the previous round e-clips and the push nuts and washers used on the idler side.

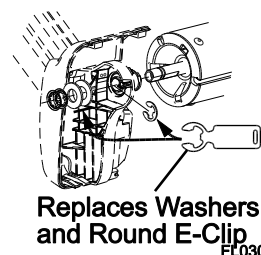

For LED replacement parts and service procedures refer to 052584-301 “LED Service Manual for Vertical Arms” available on-line at www.carefreeofcolorado.com

DUAL STAGE LATITUDE ILLUSTRATED PARTS LIST

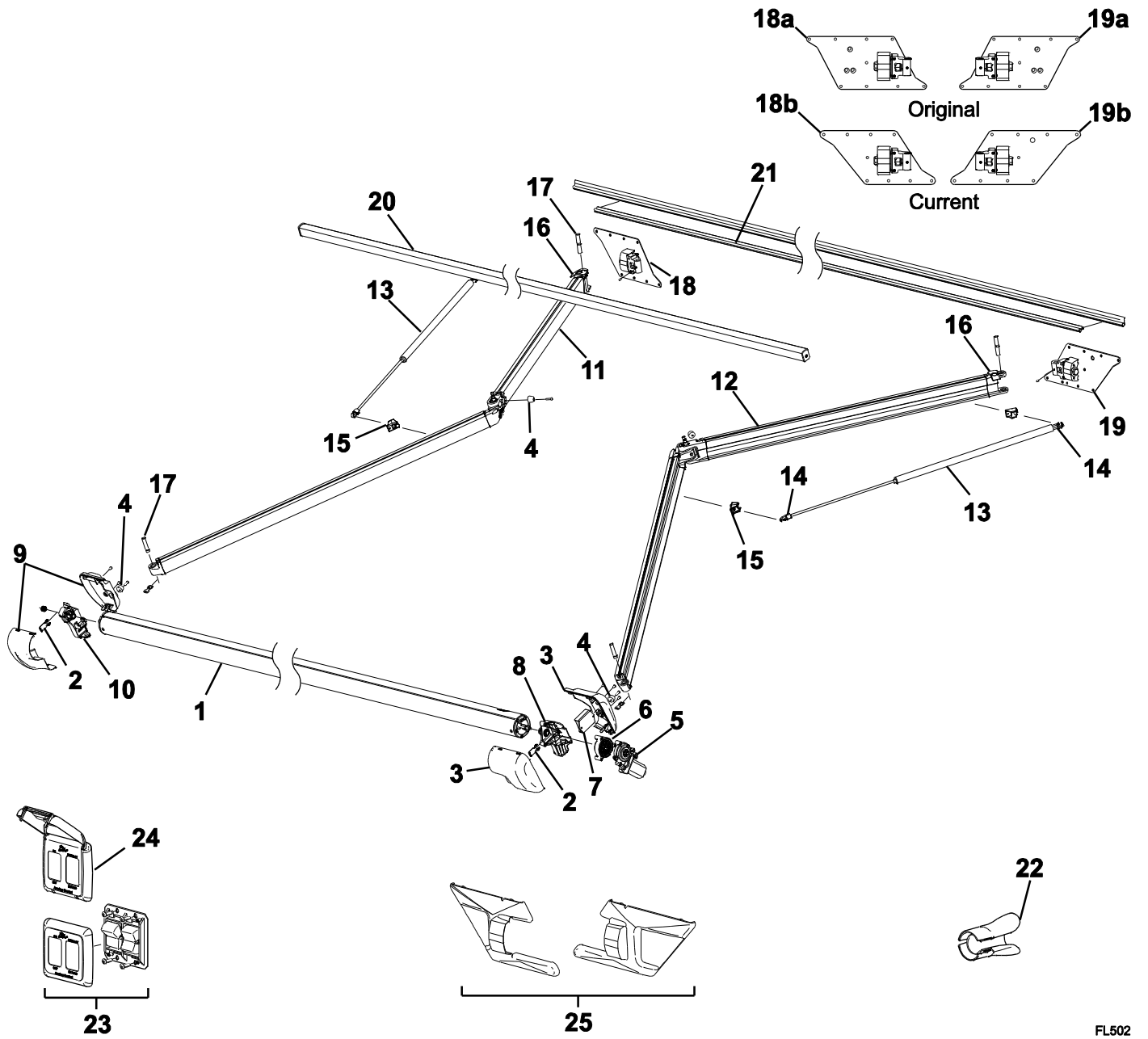

FL502

Item	Part Number	Description	Notes
1	R001782-xxx	Roller Tube Assy	2
2	R001848	Roller Tube Attach Kit	5
3	R001783-00X	Cover Kit, Motor	
4	R001798	Bumper	
5	R001784	Motor Assy	
6	R001810	Gearbox	
7	R060686-003	Sensor/Control Module, Direct Response	
8	R012659-001	Motor Bracket	
9	R001785-00X	Cover Kit, Idler	
10	R012660-001	Idler Bracket	
11	R001793-10X	Arm Assy, LH, Dual Stage	3
12	R001794-00X	Arm Assy, RH, Dual Stage	3
13	R001795	Gas Spring, Latitude Dual Stage	
14	R040905-001	Hook, Gas Spring	pkg of 2
15	R001789	Support, Gas Spring	pkg of 2
16	R001796	Ramp, Midrail	pkg of 2
17	R001791	Arm Attach Kit	One Arm 3
18a	R019376-20X	Mounting Bracket Assy, LH	Original 4
18b	R019397-00X	Mounting Bracket Assy, LH	Current 4
19a	R019376-30X	Mounting Bracket Assy, RH	Original 4
19b	R019397-10X	Mounting Bracket Assy, RH	Current 4
20	R001797-XXX-xxx	Middle Rail Assy	
21	R001792-xxx	QuicKconnect	
22	R040925-001	Canopy Funnel	
23	R019468-006	Switch Kit	
24	SR0115	Bezel Cover Kit	
25	R001977	Mounting Bracket Cover Kit	Black
	R001978	Mounting Bracket Cover Kit	White
	R060703-00X	Cable Assy, 5 Conductor	not shown
26		Canopy Only	Refer to Canopy Order Form
27	R019886-005	Screw Pack, 1/4-20 x 1" Self-drilling, White	not shown
	R019886-006	Screw Pack, 1/4-20 x 1" Self-drilling, Black	not shown
28	R019886-007	Screw Pack, 1/4 x 2" Lag, White	not shown
	R019886-008	Screw Pack, 1/4 x 2" Lag, Black	not shown

- Notes:**
- 0X = Color = 05 - White, 06 - Black; xx = Length
 - Roller tube (item 1) is complete with end bushings, LED strip
 - Arm Assemblies (items 11, 12) includes items 4, 13, 14, 15. Does not include attaching pins. For attach pins order item 17 (1 kit per arm).
 - Original and current mounting brackets are not interchangeable. Replacement brackets must match the existing brackets. Original brackets can be identified by the 3 hole pattern beside the knuckle.
 - The roller tube e-clips w/ tab replace the previous round e-clips and washers used on the idler side.

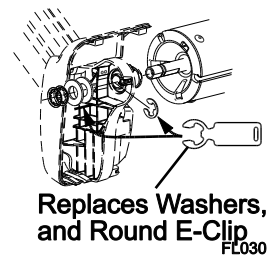

For LED replacement parts and service procedures refer to 052584-301 "LED Service Manual for Vertical Arms" available on-line at www.carefreeofcolorado.com