



CAREFREE TRUCKIN'AWN

OWNERS MANUAL /INSTALLATION INSTRUCTIONS

READ ENTIRE INSTRUCTIONS BEFORE BEGINNING OPERATION. FOLLOW ALL CAUTIONS, WARNINGS AND NOTES TO PREVENT INJURY OR DAMAGE TO AWNING OR VEHICLE. #10 x 3/4" machine screws.

2. HANGING OF TRUCKIN'AWN

A. Attach each arm assembly to the roller assembly by inserting the rivet nut into the nylon washer and then into the arm channel hole. Next, insert the arm channel into cap casting. Secure using

CUSTOMER MUST RECEIVE THIS MANUAL enough vinyl from roller
UPON INSTALLATION—MANUAL CONTAINS INSTALLATION, OPERATION, CARE

B. assembly to allow for easy nylon washer rivet insertion into awning rail.

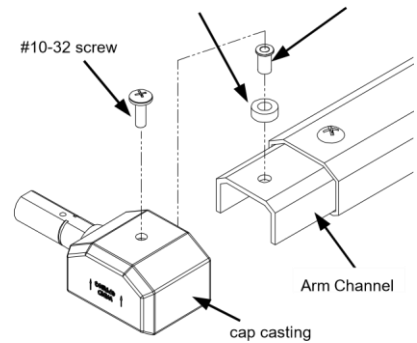

Unwrap nut

SECTION I: SAFETY INFORMATION

AND MAINTENANCE AND WARRANTY

INFORMATION awning rail and position in pre-determined left to right location over door.

C. Slide entire awning into

D. Carefully remove cotter **CAUTION: means a hazard that may cause minor or moderate injury if the warning is ignored. It also may mean a hazard that will cause damage to property.**

cause minor or moderate pins from end caps.

CAUTION: THE COTTER PINS ARE HOLDING THE

PRE-WOUND TENSION ON THE ROLLER

ASSEMBLY. CARE MUST BE TAKEN TO PREVENT ANY DAMAGE OR INJURY WHEN REMOVING PINS.

CAUTION: THE AWNING IS NOW UNDER FULL SPRING

TENSION: IF RELEASED FROM THIS POINT IT WILL ABRUPTLY

ROLL UP TO THE STORED POSITION POSSIBLY CAUSING

PERSONAL INJURY OR DAMAGE TO BOTH THE AWNING AND THE RV.

SECTION II: INSTALLATION

3. MOUNTING BOTTOM BRACKETS

Read the following specifications before beginning installation.

• **Verify that there is at least 3" of horizontal unobstructed mounting space above the door.**

and in line with the arm channel. This will be where the center line of bottom brackets are mounted. From these marks measure another set of marks. This will be where the

MEASURE FROM CENTER OF ARM TO CENTER OF AWNING HAS BRACKET CENTERS OF 4' EVEN.

possible. (If the door frame does not appear to be straight).

B. Measure down and make a mark 46.3/8" below the awning rail • **Decide where the arms will fit and not interfere with lights, ladders, etc. TRUCKIN'AWN ROLLER ASSEMBLIES** of the up 38.7/8" and make

bottom edge of the rafter mounts are positioned. **ARM. IE. 4'**

1. INSTALLATION OF AWNING RAIL

- **Verify that there is at least 2" of space for the mounting of each arm.**

- Remove awning rail from package. Apply sealer (putty tape or silicone) to the back surface of the rail.
- Determine point (left to right) where awning will best cover the door allow for the mounting of the bottom brackets and upper brace.
- Position rail at least 3" above top of door and at the predetermined right location.

NOTE: THE AWNING RAIL MUST BE INSTALLED WITH THE SLOT UP.

- Position the bottom bracket of the arms so that the previously
- Attach rail to camper made marks line up with the center line of the bottom bracket bolt. with the appropriate screws The roller assembly end caps should and or molly rivets. rest against the rubber bumpers

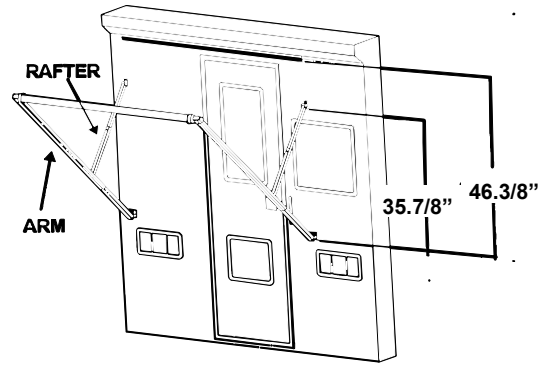

vertical
silicone)
and still
left to
POINT

installed on the awning rail. This may adjusting the arm channels by pushing arm spring button and sliding the lower upward until the spring button engages in the top hole of the outer arm

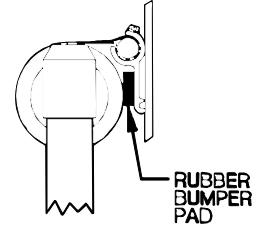

require
in on the
arm
channel.

D. Align arms vertically and install the bottom brackets using the #12 x 1" screws provided.

4. INSTALLING RAFTER SUPPORT

A. While the awning is still rolled up to the vehicle, position the support vertically and mark where the bracket will attach. Pull the top fastener of one arm and lift the end plug off of the top of the arm channel. The roller assembly should still be supported by the arm and the awning rail. Swing the arm outward and disengage **AWNING!**

B. Attach the rafter foot in the marked position.

E. **With the pull strap in the center, slowly allow the awning to**

C. Raise the arm and slide the rafter arms back together. Place the channel and install the fastener securely.

D. Do the same sequence with the opposite arm.

5. SECURING CANOPY

awning out and then back up against the wall of the vehicle. Keep your vinyl awning looking like new. Follow instructions on the roller end caps are resting against the rubber bumpers of the container. **NOTE: ALLOW CANOPY TO DRY COMPLETELY**

B. Check to see that the arms are **BEFORE ROLLING AWNING UP**, aligned properly allowing the canopy to roll up straight. Metal surfaces should be cleaned with warm soapy solution and thoroughly rinsed.

C. Drill two 3/32" holes through the awning rail, polycord and canopy approximately 2" from each end of the Like any other part of the RV, an owner should periodically inspect the canopy. Secure canopy using a #6x Screw in each hole.

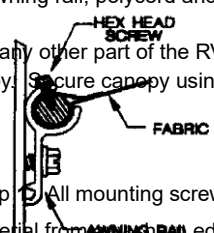

D. Fasten door corner guard to the top of the door to protect the material from enlargements of holes or broken rivets.

3. Check that the awning rail is tight against coach and all screws are

SECTION III: OPERATING INSTRUCTIONS

1. TO EXTEND AWNING

A. While standing in the door way, grasp the pull strap and pull the roller assembly outward from the vehicle until the rafter buttons engage in the holes of the rafters.

B. Once the rafter buttons engage in the holes, pull outward on the pull strap and release the rafter button **on one side only**. Once the rafter button is released, slowly release the pressure on the pull strap until the awning stops rolling up. This will release the pressure on the arm to be adjusted. Then, release the arm button and raise that arm upward to the desired position. Pull outward on the pull strap until the rafter button engages.

C. Move to opposite side and repeat the process.

D. Slide pull strap to one side and wrap it around the rafter or the arm to make it easier to enter or exit.

2. TO CLOSE AWNING

A. Position the pull strap in the middle of the roller assembly. Pull outward on the pull strap and release the rafter button **on one side only**. Once the rafter button is released, slowly release the pressure on the pull strap until the awning stops rolling up. This will release the pressure on the arm to be adjusted.

C. Move to the opposite side and repeat the process.

D. Position the pull strap in the middle of the roller assembly. Pull outward on the pull strap and release the rafter button **on both sides**. Make sure both rafter buttons are released.

CAUTION: ONCE BOTH RAFTERS ARE RELEASED, THE AWNING WILL BE UNDER FULL SPRING TENSION: IF RELEASED FROM THIS POINT IT WILL ABRUPTLY ROLL UP TO THE STORED POSITION POSSIBLY CAUSING PERSONAL INJURY OR DAMAGE TO BOTH THE CAMPER AND THE other the rafter.

roll up to the vehicle. end plug back on to the top of the arm

SECTION IV: CARE AND MAINTENANCE

1. CARE OF FABRIC

Mildew will not form on the awning material itself, but may form on dust allowed to accumulate on the canopy. A mild cleaner will A. Roll vinyl awning looking like new. Follow instructions on until the roller end

2. PERIODIC MAINTENANCE

of the door to protect the 2. Check all pivot points for

3. Check that the awning rail is tight against coach and all screws are

tight.

4. Check canopy for loose stitching and possible shrinkage.

B. Push in on the arm button on the same side, and move the arm to the lowest position. Pull outward on the pull strap until the rafter button engages.

CAREFREE MAJOR PRODUCT LIMITED WARRANTY

Carefree of Colorado (hereafter referred to as Carefree) warrants to the first retail Purchaser that the Carefree Product is free of defects in material and workmanship within the terms and conditions as set forth in the warranty statement available online at www.carefreeofcolorado.com. Carefree's obligation under this warranty is limited to the repair or replacement, at Carefree's option, of any defective component with new or factory refurbished components.

OWNER MUST RETAIN THE ORIGINAL PROOF OF PURCHASE AND/OR HAVE THE PRODUCT WARRANTY REGISTRATION ON FILE AT CAREFREE FOR WARRANTY CLAIMS.

THIS WARRANTY IS NOT TRANSFERABLE.

For

- **Warranty Duration;**
- **Warranty Coverage and Exclusions;**
- **Warranty Terms of Coverage; and,**
- **Warranty Claim Procedures**

Refer to publication

**052580-111 "Carefree Major Product Limited Warranty"
available online at www.carefreeofcolorado.com**

Register your Carefree products on-line at www.carefreeofcolorado.com

IMPORTANT NOTICE: It is strongly recommended that adjustments and repairs be performed by trained technicians at your Authorized Carefree Dealer. Work performed by non-authorized persons or businesses may void warranty.