



SERVICE MANUAL

MIRAGE 2-STAGE AWNING

Product style code: DL

RV



Read this manual before installing or using this product. Failure to follow the instructions and safety precautions in this manual can result in personal injury and/or cause the product to not operate properly.

For LED replacement parts and service procedures refer to 070013-301 “LED Service Manual for Box Awnings” available on-line at www.carefreeofcolorado.com



IMPORTANT NOTICE: The adjustments and repairs described in this book should be performed by trained technicians at Authorized Carefree Dealerships. Work performed by non-authorized persons or businesses may void warranty.

TABLE OF CONTENTS

Product Overview	1
Standard System Adjustments	2
Adjusting the Motor Limits.....	2
OUT Limit Switch	2
Adjusting the IN Limit Switch	3
Adjusting the Pitch.....	3
Mounting Height.....	3
Manual Override	4
Programming the RF Receiver for a Remote.....	5
Canopy Replacement	6
Motor Replacement	8
Arm Replacement	11
Replacing the Lead Rail Connector:	12
Replacing the Case Arm Support	12
Diagnostics	13
Common Operation Items.....	13
Diagnostic Tests – Direct Response for Single Awning.....	14
Testing the System – Single Awnings.....	14
Diagnostic Tests – Direct Response for Multiple Awnings.....	17
Testing the System – Multiple Awnings.....	17
Electronics	21
Wiring Diagram – Single Awning.....	22
Wiring Diagram – 2-Awnings	23
Wiring Diagram – 4 Awnings.....	25
Connection Flex w/ "110VDR" Control Boxes	27
Optional Manual Bypass Switch.....	27
Sensor Replacement for Direct Response	28
Standard Maintenance	29
Fabric Care.....	29
Mildew.....	29
Pooling.....	29
Arm Care	29
Hardware Maintenance	29
Motor Maintenance	29
Part Number Listing	30
Part Number/Serial Number Location	30
Illustrated Parts List	30
Electronics	32

PROPRIETARY STATEMENT

The Mirage 2-Stage Patio Awning is a product of Carefree of Colorado, located in Broomfield, Colorado, USA. The information contained in or disclosed in this document is considered proprietary to Carefree of Colorado. Every effort has been made to ensure that the information presented in the document is accurate and complete. However, Carefree of Colorado assumes no liability for errors or for any damages that result from the use of this document.

The information contained in this manual pertains to the current configuration of the models listed on the title page. Earlier model configurations may differ from the information given. Carefree of Colorado reserves the right to cancel, change, alter or add any parts and assemblies, described in this manual, without prior notice.

Carefree of Colorado agrees to allow the reproduction of this document for use with Carefree of Colorado products only. Any other reproduction or translation of this document in whole or part is strictly prohibited without prior written approval from Carefree of Colorado.

SAFETY INFORMATION



This is the safety alert symbol. It is used to alert individuals to potential personal injury hazards. Obey all safety messages that follow this symbol to avoid possible personal injury or death.



Indicates a hazardous situation, which if not avoided, could result in death or serious bodily injury.



Indicates a hazardous situation, which if not avoided, may result in minor or moderate bodily injury.



Indicates a situation that may result in equipment-related damage.

General Safety:



This product can expose you to chemicals including Di-isodecyl phthalate (DIDP), Vinyl Chloride and Formaldehyde, which are known to the state of California to cause cancer or birth defects or other reproductive harm. For more information visit www.P65warnings.ca.gov



Shock Hazard. Always disconnect battery or power source before working on or around the electrical system.



Always wear appropriate safety equipment (i.e. goggles).



Always use appropriate lifting devices and/or helpers when lifting or holding heavy objects.



When using fasteners, do not over tighten. Soft materials such as fiberglass and aluminum can be "stripped out" and lose the ability to grip and hold.

Electric components in this product have been tested by the following agencies:



Motor: UL Recognized (USA)
CSA Approved (Canada)



Controls: UL Listed (USA & Canada)

PRODUCT OVERVIEW

Specifications

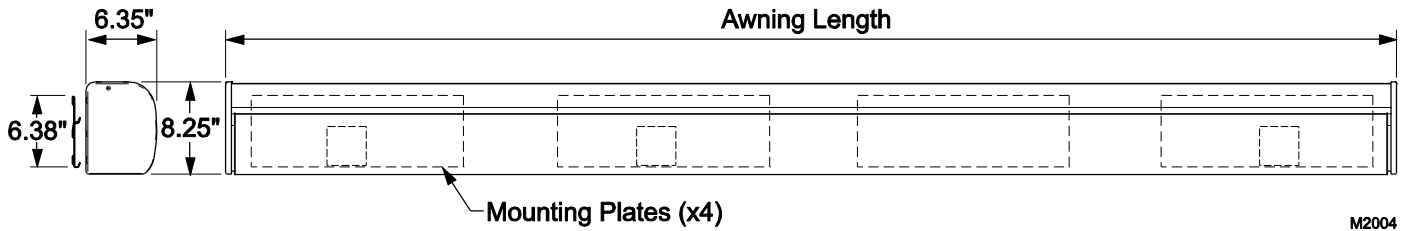

M2004

NOTE: Dimensions are at maximum extension and shown for reference only. Refer to installation manual for required mounting heights and positions. Values are approximate, actual dimensions may vary with specific installations.

LENGTH	14' – 21' [4.27m - 6.4m] (in 1 foot [.305m] increments)		
HORIZONTAL PROJECTION	110" [279.5cm]	@ minimum pitch	
	98" [249cm]	@ maximum pitch	
DROP:	42" [107cm]	@ minimum pitch	
	64" [162.5cm]	@ maximum pitch	
SUPPORT:	Lateral Spring Arms		
MOTOR:	Tubular	Available in LH or RH configurations	
	Power:	120V, 60Hz, 2.5A	Torque: 60nm Speed: 14 RPM
CONTROLS:	Carefree Direct Response		
COLOR:	Hardware:	Black	
	Fabric:	Woven Acrylic (refer to sales literature for colors)	

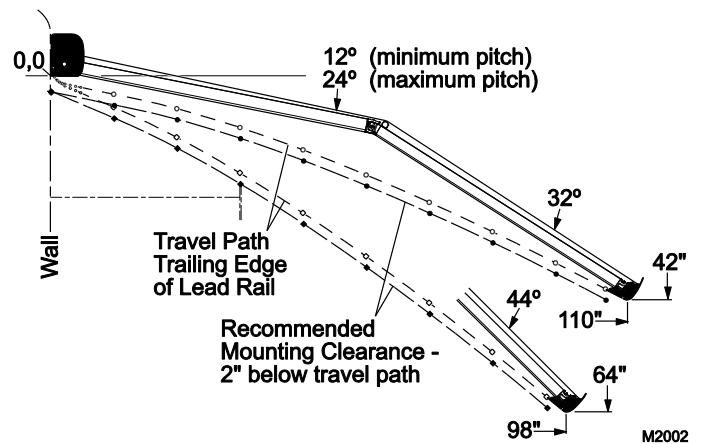

M2002

Optional factory installed 12V LED lighting (mounted in the lead rail) is available for the Mirage 2-Stage awning. LED lighting requires a separate 12V control switch.

There are two configurations of the Mirage 2-Stage based on the canopy construction as shown.

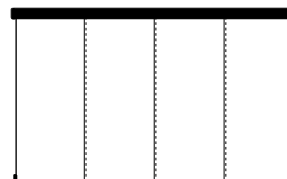

VS Configuration
Canopy construction with vertical seams

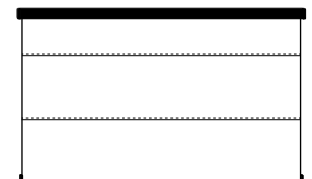

HS Configuration
Canopy construction with horizontal seams

Mirage056

STANDARD SYSTEM ADJUSTMENTS

ADJUSTING THE MOTOR LIMITS

The motor limit switches are preset at the factory for best operation of the awning. The "OUT" limit switch is used to stop the motor when the awning is fully extended. The "IN" limit switch is used to stop the motor when the awning is fully retracted. The "IN" limit is NOT USED when the *Direct Response* system is installed.

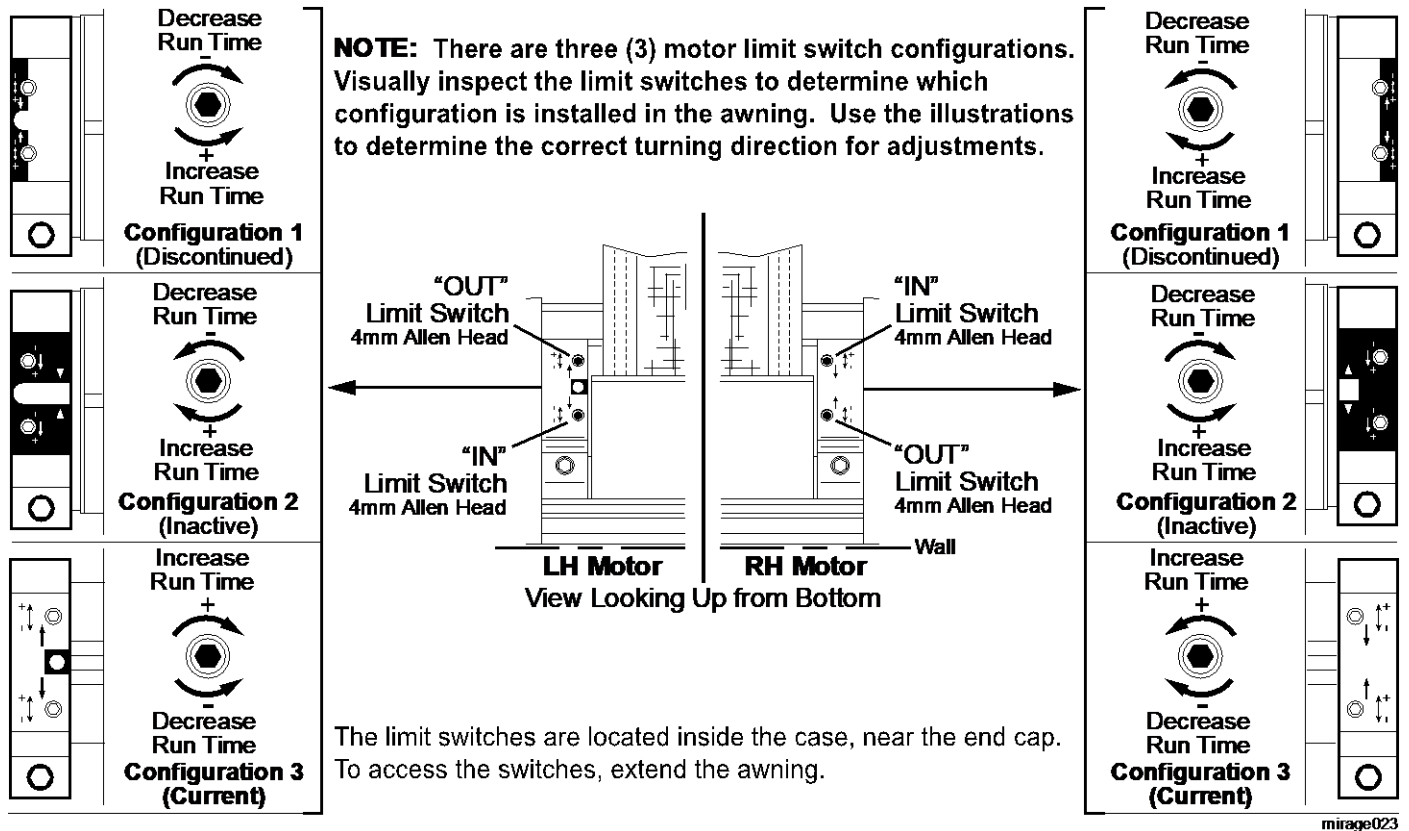

OUT Limit Switch

The "OUT" limit switch stops the motor when the awning is fully extended.

1. Extend the awning out completely.
2. Confirm that the arms are fully extended. The motor should stop and the fabric should be tight. If the motor continues to run, the fabric will sag; or, if the motor quits before the arms are fully extended, it will be necessary to adjust the "OUT" limit switch.

NOTE: It is best to make the adjustments in increments of a single turn. 3 full turns of the screw equals approximately 2" of fabric extension.

3. If the fabric sags:
 - 3.1. Retract the awning until the fabric is tight then retract an addition 10"-12".
 - 3.2. Using a 4mm Allen wrench turn the "OUT" limit switch to reduce the time the motor runs.
 - 3.3. Extend to confirm that the adjustment is correct.
 - 3.4. Repeat the procedure until the awning extends correctly.
4. If the arms do not extend completely:
 - 4.1. Retract the awning approximately 10"-12".
 - 4.2. Using a 4mm Allen wrench turn the "OUT" limit switch to increase the time the motor runs.
 - 4.3. Extend to confirm that the adjustment is correct.
 - 4.4. Repeat the procedure until the awning extends correctly.

Adjusting the IN Limit Switch

NOTE: The "IN" limit switch is not adjusted when the Direct Response system is installed. The system electronics monitors the motor and shuts the motor off when the awning is fully retracted.

If the IN limit switch is accidentally adjusted, the motor may shut off before the awning is fully closed. If this occurs, turn the "in" adjustment screw to increase the motor run time. It is not necessary that the screw matches the closed position. The Direct Response electronics control the closed position.

NOTE: It is normal for the lead rail to slightly relax after the awning closes completely.

ADJUSTING THE PITCH

Mounting Height

When adjusting the pitch, it is important to check the clearance above any projections such as open doors or slide outs. The chart below provides the recommended clearance allowances based on the minimum distance from the top of a projection (i.e. open door or slide out) to the bottom of the mounting plate ("B"). This provides clearance for the travel path of the lead rail.

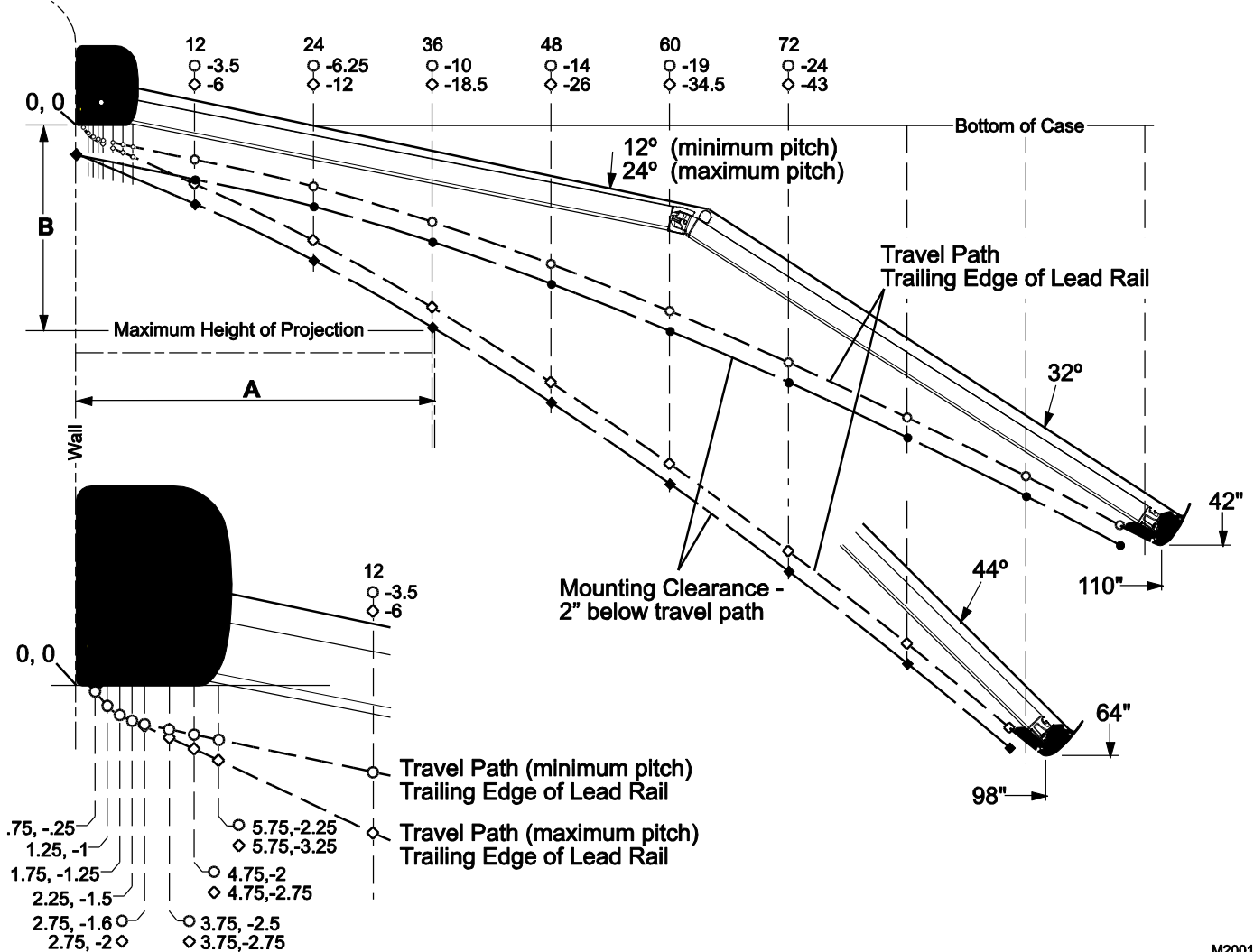

M2001a

A Projection (Door/Slideout) →	0"	12"	24"	36"	48"	60"	72"
● B Min. Mounting Height (min. pitch) ↑	3"	5.5"	8.25"	12"	16"	21"	26"
◆ B Min. Mounting Height (max. pitch) ↑	3"	8"	14"	20.5"	28"	36.5"	45"

The minimum mounting height (B) is measured from the uppermost edge of the projection (i.e. door, slideout room flange) to the bottom of the mounting plate. The value given is a minimum requirement, adjust upward as required to clear casing, trim etc.

NOTICE During installation or when the pitch of the awning is adjusted, it is important that the leadrail is parallel to the awning housing.

1. Extend the awning fully.

To Lower the Pitch:

2. SLIGHTLY loosen the M12 hex screw on the side of the knuckle.
3. On the front of arm knuckle turn the M12 hex screw COUNTERCLOCKWISE to lower the pitch.
4. Tighten the M12 setscrew until snug.

To Raise the Pitch:

5. SLIGHTLY loosen the M12 hex screw on the side of the knuckle.
6. Loosen the M12 set screw several rotations.
7. On the front of arm knuckle turn the M12 hex screw CLOCKWISE to raise the pitch.

NOTE: When raising the pitch, it is helpful to have a second person lift up on the lead rail.

8. Tighten the M12 set screw until snug.
9. Repeat steps 5 through 8 for the other end.
10. When the pitch adjustments are completed, tighten the M12 screws on the side of the knuckle.

When the pitch is adjusted, it is necessary to adjust the angle of the lead rail for the awning to close correctly.

11. SLIGHTLY loosen the M12 nut on the side of each arm knuckle on the lead rail.
12. Turn the M12 setscrews of each knuckle to increase or decrease the angle of the lead rail. The bottom of the lead rail should be parallel with the ground.
13. When the lead rail adjustments are completed, tighten the nut on the side of the knuckles.

MANUAL OVERRIDE

If 110V power is not available to the vehicle, the awning can still be safely retracted using the manual override. The bypass may be accessed from inside the case on the motor housing or from the top of the case above the motor housing.

To use the inside bottom access: The awning must be open a minimum of 8" to afford access to the override.

To use the top bypass access: Remove the screw and well nut that is used to secure the end cap.

1. Chuck the 7mm hex key into a 3/8" battery powered drill.
2. Insert the hex key into the manual override on the awning. For the top access, it will be necessary to locate the hex by feel; it is not visible with the key inserted in the hole.
3. Operate the drill in the forward (clockwise) direction to close the awning. Reverse the drill to open the awning.

NOTE: When using the bottom override, the awning can only be closed within 6-8". It will be necessary to use the top access to close the awning completely.

4. When done, return the screw and well nut to the top of the case if removed.

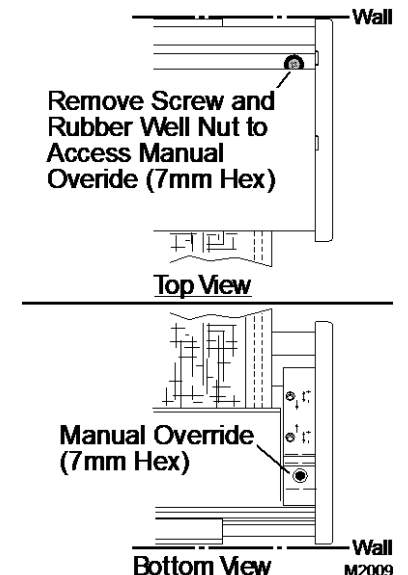
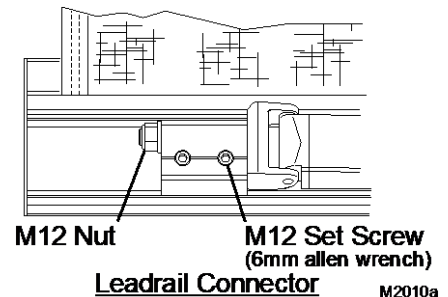
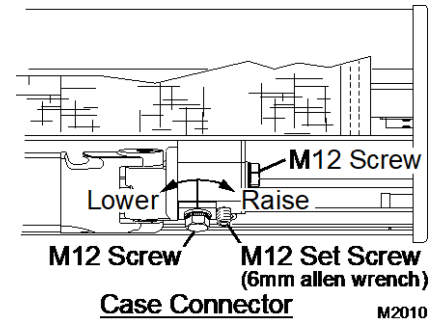

PROGRAMMING THE RF RECEIVER FOR A REMOTE

When adding or replacing a remote control or receiver, it is necessary to program the transmitter and receiver.

1. Power to the control box must be on.
2. Locate the receiver box.
3. Press and release the "Press to Learn Transmitter" button on the bottom of the receiver. The receiver is in program mode when the red light comes on.
4. *For Single Awning Key FOBS:* Press and release the STOP button on the remote. The red light will go out after the receiver learns the remote signal.

NOTE: Pressing the stop button will cause the blue up arrow button to default as the open (extend) function.

If a function button is pressed to train the receiver, it will be programmed as the open (extend) button. Example: Pressing the bottom button will program the bottom button for extend and the top button as retract.

5. *For Multiple Awning Remotes:* Press and release the ANY button on the remote. It is recommended to use the STOP button. The red light will go out after the receiver learns the remote signal.

CAUTION When the receiver learns the transmitter signal, the system will perform the operation of the button pressed. Example: Pressing an "Extend" button during the learning phase will cause the awning to extend when the receiver learns the signal. Use caution to avoid unexpected movement by the awning.

6. Repeat for each additional remote.

OPERATIONAL NOTES:

- The transmitter and receiver operate on a frequency of 433MHz.
- The receiver exits the program mode after ten seconds.
- If the light does not come on in step 2, the memory is full and must be cleared. If the light still does not come on, check the continuity of the cord between the boxes and repair or replace as required. Pin 1 of the 1st connector goes to pin 1 of the 2nd connector etc.
- If the light does not go out above, the receiver knows the transmitter signal or the battery in the Remote needs to be replaced.
- To clear the memory: PRESS AND HOLD the receiver learn button. While holding the button, the indicator light should be OFF for the full 5 seconds then come on.
- The receiver may be programmed for up to 5 remotes. Additional remotes may be ordered separately.

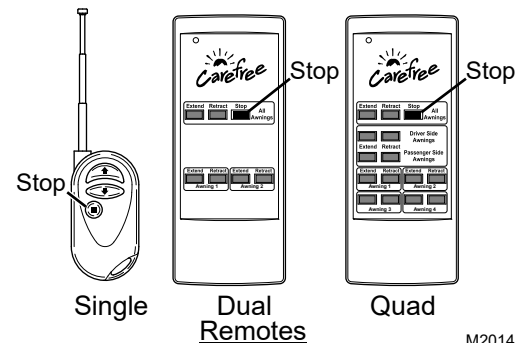
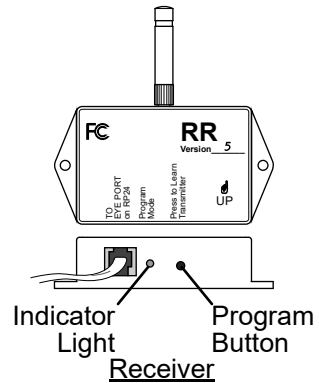

M2014

CANOPY REPLACEMENT

1. Disconnect power to the awning.
2. Using the manual override (page 4), open the awning 18"-24".
3. Carefully push the lead rail toward the case so that the arms collapse and the fabric is slack.
4. While holding the leadrail firmly tie the elbows of the outer spring arms together. Use a minimum 1/2" rope - do not use bungee cords. When tying the rope, use a non-slip knot such as a square knot or equivalent.

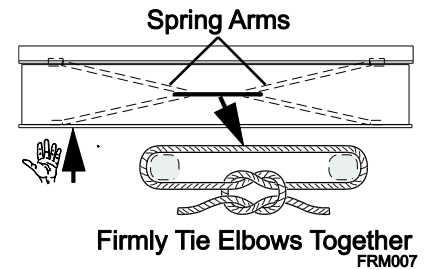

CAUTION Failure to secure the lead rail as described will allow the spring arms to extend out possibly causing personal injury and damage to the awning.

5. Remove the outer end cap.
 - 5.1. For machined aluminum end caps, remove the two screws. There is one inner and outer screw.
 - 5.2. For molded end caps, snap the bottom out and lift up. No screws are used with the molded end cap.

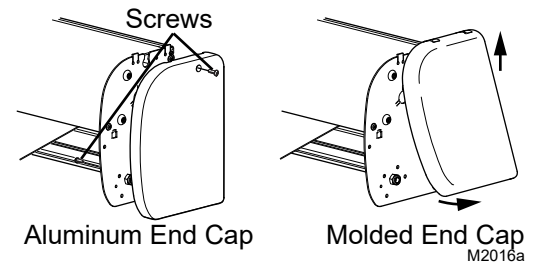

6. Remove the two (2) fabric retainer screws from lead rail and set aside.
 - 6.1. For older units, the screws are located on the back of the lead rail.
 - 6.2. *For HS units with the 3.5" roller tube:* remove the leadrail endplates. The retaining screws are located in the fabric slot.

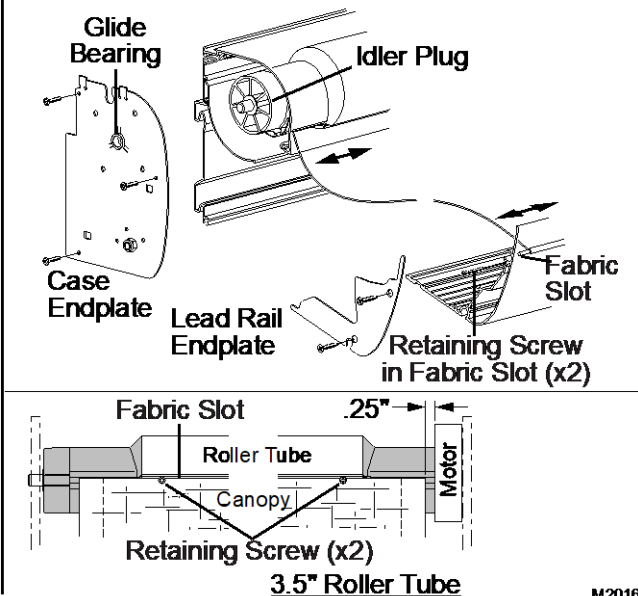
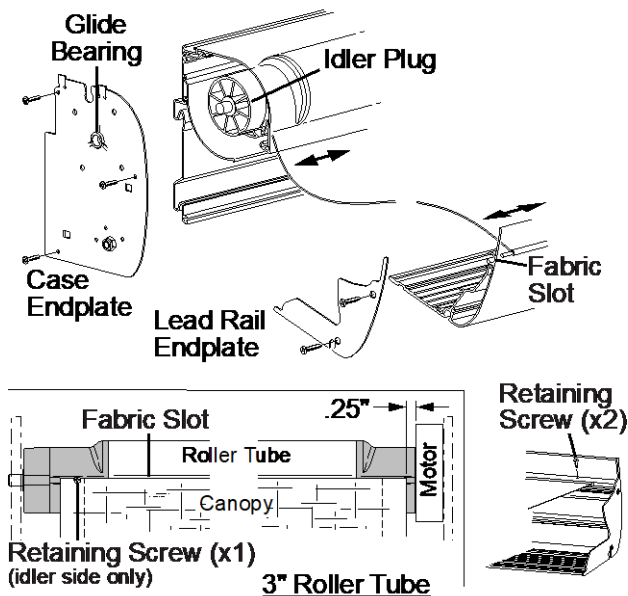

7. For older units, remove the idler side endplate from the lead rail assembly.
8. Remove the idler case endplate.

NOTE: It will be necessary to firmly support the roller tube and keep it from coming out of the case.
9. From the idler end of the roller tube, simultaneously slide the old canopy out of the roller tube and lead rail.
10. Inspect the slots in the roller tube and lead rail. Clean and deburr as required. Lightly spraying the inside of the slot with a dry silicone lubricant will aid in sliding the new fabric.
11. Slide the new canopy into the lead rail and roller tube. Both edges must be done at the same time. Orient the fabric so that the large polycord goes into the lead rail, the smaller polycord goes into the roller tube. The hem should be on the down side.

12. The canopy should be approximately .25" from the end of the motor crown.
13. Stake the canopy with #8 x 1" flat head screw(s). The screw goes through the material, polyrod and roller tube in the fabric slot.
 - 13.1. For older units, one fabric screw is located on the idler side.
 - 13.2. For current units with the 3.5" roller tube, there is a retaining screw on both ends of the roller tube.
14. Remove any support material from the roller tube and install the case endplate.
15. Use the manual override to roll the canopy onto the roller tube, the material rolls under the roller tube. Ensure the fabric rolls evenly onto the roller tube without wrinkling or folding.
16. Once the fabric is snugly rolled up, remove the rope used to tie the arms together.
17. Restore power to the awning.
18. Extend and retract the awning. Ensure the fabric rolls evenly onto the roller tube without wrinkling or folding. Adjust the canopy position in the leadrail as necessary.
19. Stake the canopy on the one side of the leadrail. On the other end, pull the fabric smooth in the leadrail and stake.
20. If removed, attach the leadrail endplates.
21. Install the end cap.
22. It may be necessary to adjust the motor limits. Refer to page 2.

MOTOR REPLACEMENT



! WARNING Shock Hazard. Always disconnect battery or power source before working on or around the electrical system.

There are three (3) motor replacement configurations.

- a) VS configuration – with 3" diameter steel roller tube.
- b) HS configuration – with 3" diameter steel roller tube and necked down idler plug and crown.
- c) HS configuration – with 3.5" diameter aluminum roller tube and necked down idler plug and crown.

This procedure requires two people.

1. Disconnect power to the awning.
2. Disconnect the motor wires at the junction box or control box and pull the cable out.
3. Remove the phillips head screw and rubber well nut from the top of the case.
4. Remove the outer end cap.
 - 4.1. For machined aluminum end caps, remove the two screws. There is one on the outside and one on the inside of the case.
 - 4.2. For molded end caps, snap the bottom out and lift up. No screws are used with the molded end cap.
5. Use the manual override (refer to page 4) to over extend the awning. The arms should be extended completely, the canopy should be relaxed and the fabric slot of the roller tube should point toward the fabric slot in the case.

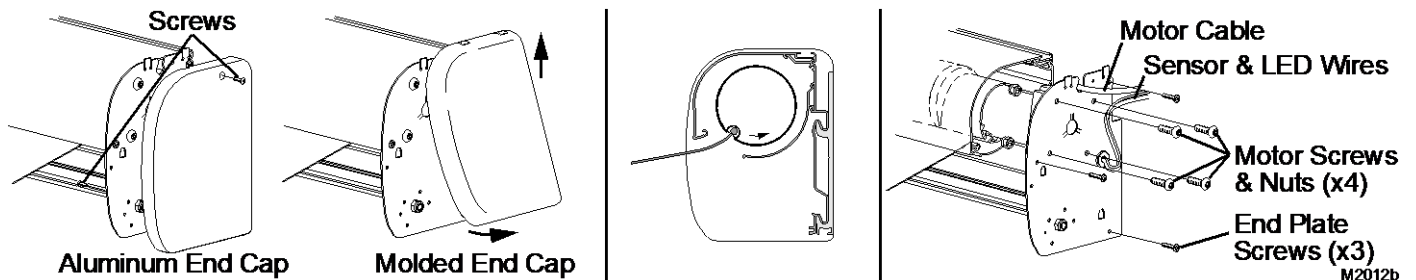

6. Remove the attaching screws for the end plate then carefully pull the end plate and motor partially out from the awning case.

NOTICE When pulling the motor, do not let the roller tube come out more than 1"; otherwise the idler will disengage from the opposite end plate. If this occurs, reinsert the idler into the endplate before continuing.

NOTICE When pulling the motor out of the case, the servicing technician must use care to not break or damage the sensor and LED cables routed through the end plate.

NOTE: When pulling the motor, it will be necessary to firmly support the roller tube to keep it from coming out of the case. Do not let the roller tube come out more than 1"; otherwise the roller tube idler will disengage from the opposite end plate. If this occurs, reinsert the idler into the endplate before continuing.

7. Remove the attaching screws and nuts holding the motor to the end plate. Make note of the motor orientation on the end plate.
8. Slide the end plate along the remaining wires and out of the way then remove the motor with the crown and drive.

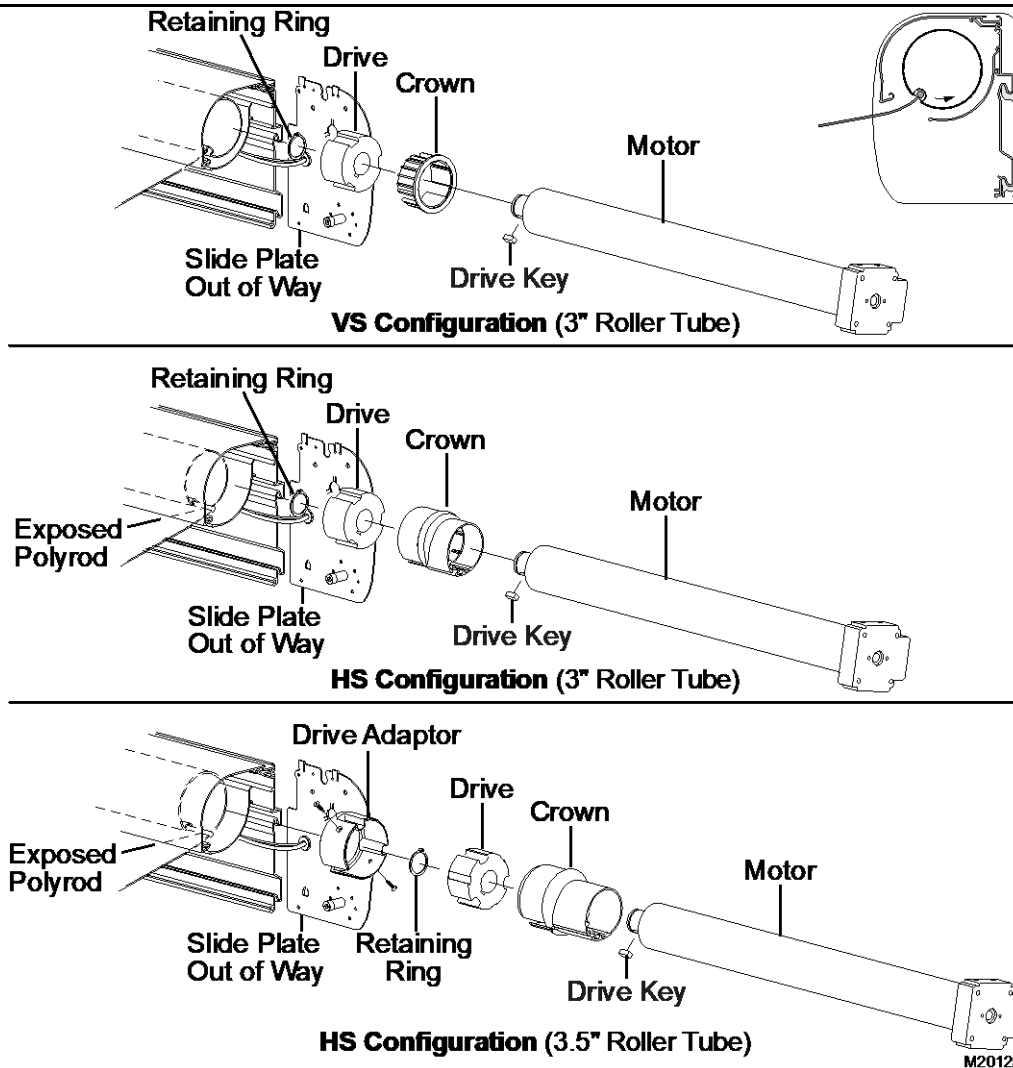

NOTE: *For the HS configuration:* When the crown is removed the canopy edge with the polyrod will be exposed and extend past the roller tube.

9. *For HS configuration:* Remove the crown from the old motor. This will be used with the new motor. The crowns are configuration specific.
10. Assemble the new motor:

NOTE: Except as noted, the new and old motor components are not interchangeable.

 - 10.1. Slide the crown onto the motor.

NOTE: *For VS configurations,* use the new crown that is included with the motor. *For HS configurations,* discard the included crown and use the existing crown that was removed previously.
 - 10.2. Place the drive key into the slot of the motor shaft and slide the new drive onto the motor shaft and over the drive key.
 - 10.3. Secure the drive using the supplied retaining ring.
 - 10.4. *For HS units with the 3.5\"* roller tube: Attach the drive adaptor over the drive and secure with two (2) #8 x .75\" self-drilling screws.
11. Partially insert the new motor with the crown and drive into the roller tube. Ensure that the motor drive gear and crown are properly seated inside the roller tube.

NOTICE *For the HS configuration:* When the crown is seated in the roller tube, the canopy edge with the polyrod must be in the fabric groove of the crown.

12. Attach the end plate to the motor the using the new screws and nuts provided. Make sure to match the orientation from the old motor.

13. Route the new motor cable through the end plate.
14. Press the motor and end plate into the roller tube and attach the end plate to the housing using the screws removed previously.
15. Route the new motor wire into the vehicle and attach at the junction box or control box (refer to wiring diagrams on page 21 for the appropriate control system). **All wiring must conform to NEC (National Electrical Code) and local codes.**
16. Use the manual override to roll the canopy onto the roller tube. The fabric must roll under the roller tube.
17. Install the end cap.
18. To test, restore power then extend and retract the awning.
19. It will be necessary to adjust the motor limits. Refer to page 2.

ARM REPLACEMENT

CAUTION The spring arm is under tension to open. Use extreme care to firmly hold the spring arms during assembly and disassembly to avoid any sudden or unexpected movement by the arm. Serious personal injury and/or property damage could occur.

It is recommended that the following procedure is done with two people.

1. Open the awning to the maximum extension or as wide as possible. This is to minimize the spring tension in the arms during this procedure.
2. Disconnect power to the awning.
3. If replacing an outer arm it will necessary to firmly support the lead rail and middle rail during disassembly and assembly.
4. For arms with the sensor cable mounted, carefully remove the sensor cable from the wire channel on top of the arm. Use care to not bend, break or compromise the cable.
5. (*Detail A*) At the middle rail remove the two (2) 1/4-20 screws that attach the rail support to the arm. Do not discard screws.
6. (*Detail B*) At the lead rail, remove the M12-1.25 lock washer and nut from the arm and lead rail connector.
7. Slightly loosen the 6mm adjustment screw. Do NOT loosen the outer set screw.
8. Firmly grasp the spring arm and slide the lead rail arm knuckle out of the lead rail connector. Allow the arm to extend to its maximum length outside the lead rail. Have a second person hold or otherwise support the unattached end.
9. (*Detail C*) Inside the case, remove the M12-1.25 x 25 bolt and washer from the side of the arm support. Remove the M12-1.25 x 40 bolt, washer and saddle from the front of the support.
10. Slightly loosen the 6mm locking screw.
11. Firmly grasp the spring arm and slide the case arm knuckle out of the arm support. Set the arm aside.
12. (*Details D & E*) Remove the set screws, rotation pins and knuckles from the old arm.
13. Attach the knuckles to the new arm as shown. Make sure that the orientation is the same as the old arm.

If replacing the lead rail connector or case arm support, go to page 12 then return to step 14.

14. Using two people firmly hold the new arm assembly and remove the shipping ties. Allow the arm to slowly open to its maximum extension.

Tip: Use a floor or ground cover and place one knuckle and arm half on the ground. Have one person firmly hold the arm half on the ground while the second person carefully opens the other arm half.

15. Lift the arm assembly into position.

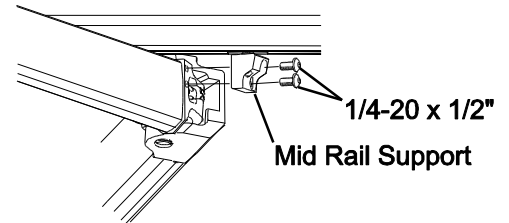

Detail A (Mid Rail)

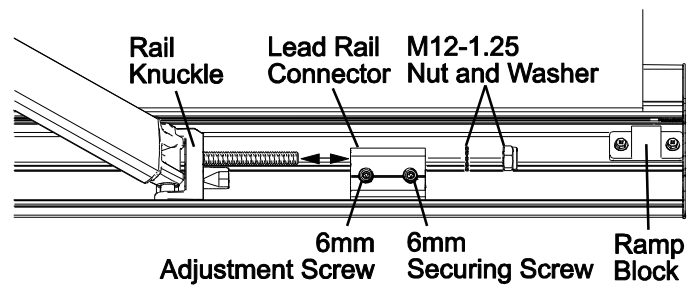

Detail B (Lead Rail)

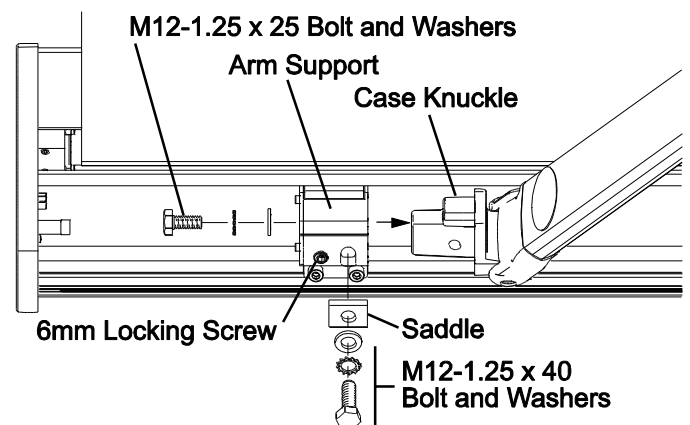

Detail C (Case)

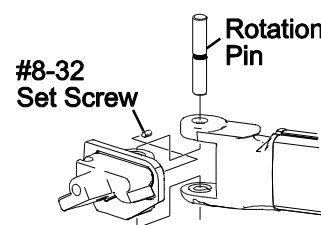

**Detail D
(Case Knuckle)**

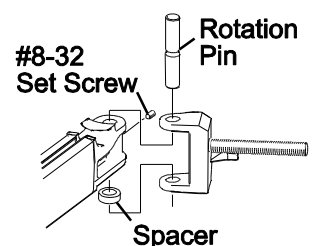

**Detail E
(Lead Rail Knuckle)** M2011

16. *(Detail C)* Slide the case arm knuckle into the support inside the case and secure with 1 each M12-1.25 x 25 bolt and washer and 1 each M12-1.25 x 40 bolt, washer and saddle. Do not tighten at this time.
17. *(Detail B)* Insert the lead rail arm knuckle into the lead rail connector and secure with 1 each M12-1.25 bolt, washer and nut. Do not tighten at this time.
18. *(Detail A)* Reattach the arm to the mid rail support using the two (2) 1/4-20 screws removed previously.
19. *If the sensor cable is routed on the replacement arm:* Route the cable through the wire channel in the arm. At the arm joints, arch the cable slightly to avoid binding. Do not twist the cable.
20. Adjust the arm pitch as required. Follow the procedure for pitch adjustment on page 2.

Replacing the Lead Rail Connector:

1. Remove the lead rail end plate and ramp block.
2. Carefully mark the location of the existing connector.
3. Loosen the 6mm securing screw and slide the existing connector from the lead rail.
4. Insert the new connector assembly into the lead rail and position at the marks made previously.
5. Tighten the outer 6mm securing screw.
6. Attach the lead rail end plate.
7. Return to step 14 on the previous page.

Replacing the Case Arm Support

1. Carefully mark the location of the existing support.
2. Remove the end cap if installed.
3. Remove the end plate.
 - *For the idler side*, remove the end plate screws then slide the end plate off of the roll bar idler and set aside.
 - *For the motor side*, pull the motor and end plate out slightly and rotate out of way. Use care to not break, bend or damage the wires.
4. Loosen the clamping screws on the support and slide the old support out of the case.
5. Insert the new support assembly into the case and position at the marks made previously.
6. Tighten the clamping screws.
7. Reinstall the end plate. Ensure that the idler pin of the roll bar is properly seated
8. Reinstall the end caps.
9. Return to step 14 on the previous page.

DIAGNOSTICS

COMMON OPERATION ITEMS

The following items are operational items that may come up as questions during normal operation. These are also given in the operator's manual.

1. If the optional Carefree EL ignition lockout is installed the system will disable the extend function while the vehicle ignition key is in the ON position.
 - 1.1. Special order RTL ignition lockouts will fully retract the awning(s) and disable the extend function.
 - 1.2. Functions will return to normal operation when the ignition key is turned OFF.
 - 1.3. Coach manufacturers may install their own lockout design. Refer to the coach literature for AC power for accessories.
2. Direct Response Controls:
 - 2.1. When 110VAC power is removed from the system, the controller DOES NOT retain previous positioning information. When power is restored, positioning information is updated when the first function is initiated.
 - 2.2. The function LEDs (extend, retract and stop) perform a dual function. When the button is pressed, the LED illuminates. The LED stays illuminated during the selected operation and after the awning has fully extended or retracted. This provides an indicator of the awning position. When the stop button is pressed, the LED will illuminate and stay on until a function is pressed. If on, it indicates that the awning is partially extended/retracted.
 - 2.3. All function buttons are press ON/press OFF. The auto-functions will continue until the awning is fully extended/retracted or when the stop button is pressed.
3. Each awning has an independent motion sensor. During windy conditions, the awnings may not retract concurrently.
4. For multiple awning installations: Pressing multiple buttons at the same time may cause the awnings to appear to move erratically. If this occurs, press the stop button. Use the individual controls to set the awning(s) to the desired position.
5. When 110VAC power is removed from the system, the controller DOES NOT retain previous positioning information. When power is restored, positioning information is updated when the first function is initiated.

DIAGNOSTIC TESTS – DIRECT RESPONSE FOR SINGLE AWNING

Refer to the Wiring Diagrams in the next section for wire and cable connections.

TESTING THE SYSTEM – SINGLE AWNINGS

The function LEDs (extend, retract and stop) perform a dual function. When the button is pressed, the LED illuminates. The LED stays illuminated during the selected operation and after the awning has fully extended or retracted. This provides an indicator of the awning position. When the stop button is pressed, the LED will illuminate and stay on until a function is pressed. If on, it indicates that the awning is partially extended/retracted.

All function buttons are press ON/press OFF. The auto-functions will continue until the awning is fully extended/retracted or when the stop button is pressed.

1. While observing the control panel, have a second person initiate 110VAC power to the coach and awning system. The following should occur:
 - 1.1 The Auto-Retract and Wind Speed LEDs should illuminate briefly then extinguish.
 - 1.2 The Power ON/OFF and function/position LEDs will briefly illuminate.
 - 1.3 The system then goes to the default settings: The POWER “ON”, AUTO-RETRACT “ON” and MEDIUM Wind Speed LED will be on.

NOTE: The function/position LEDs (extend, stop and retract) will not be illuminated. During power up the controller does not retain position information. The controller is updated with the first function used.

2. Press the POWER “OFF”. ALL LEDs should extinguish. The POWER ON/OFF button disables all functions including Auto-Retract and the optional RF remote if installed. It does not disconnect the 110VAC power.
3. Press the POWER “ON”. Press the EXTEND button, the LED should illuminate while the awning extends and stay on after the awning auto-stops. Observe the awning, it should fully extend. The system performs an auto-tension action when the awning is fully extended. The awning rolls in reverse to tension the fabric. The auto-tension feature works only with the extend function when the awning is fully extended or the stop button is pushed while extending.
4. After the awning is fully extended, press the RETRACT button, the EXTEND LED should extinguish and the Retract LED should illuminate while the awning is retracting. Press the STOP button.
5. When the STOP button is pressed, the awning will stop, the RETRACT LED should extinguish and the STOP LED should illuminate.
6. Press the RETRACT button, allow the awning to retract fully, the Retract LED will illuminate and stay lit.
7. Press the AUTO-RETRACT OFF. The AUTO-RETRACT and WIND SPEED LEDs should go out.
8. Press the AUTO-RETRACT ON. Press each Wind Speed button and confirm that the LEDs illuminate.
9. Test the Auto-Retract function:
 - 9.1 Fully extend the awning.
 - 9.2 With the AUTO-RETRACT ON, set the WIND SPEED to the lowest setting.
 - 9.3 Create a firm but gentle rocking motion with the leading edge of the awning. The awning should retract after 2-3 seconds of the motion.
10. *If the optional Ignition Sensor is installed:*
 - 10.1 Partially retract the awning.
 - 10.2 Turn the ignition key ON.
 - 10.3 Press the EXTEND button. The LED should flash for 2 seconds then shut off and the previous function LED will come back on.

In the charts below, YES is a positive response to the test; NO is a negative response.

D01 THE AWNING DOES NOT OPERATE			
A	Confirm 110VAC power to control box.		
	1. Shut off power source. 2. Open control box. 3. On some early units a fuse is installed on the circuit board (if installed). Check that fuses on circuit boards are intact. 4. Check that 110VAC connections are correct and secure. Refer to correct system schematic.	YES	Power is present; go to test B
		NO	Check vehicle circuits and fuses. Repair as required and retest
B	Confirm awning motor is functioning		
1	1.1 With power off, disconnect motor wires and AC power in from switches (system #1) or control box. 1.2 Connect awning motor directly to 110VAC power source. Motor White to Neutral (White) of AC cord Motor Green to Ground (Green) of AC cord Motor Red & Black are Motor Direction Control – connect Red to AC Hot (Black). 1.3 While observing awning, briefly apply power. 1.4 Disconnect power and attach other motor direction control wire (Black) to AC Hot (Black). 1.5 While observing awning, briefly apply power. 1.6 Does awning move when power is applied? Note: If the awning runs but does not extend or retract completely, it may be necessary to adjust the motor limits (refer to page 2).	YES	Awning motor is good, control circuit is defective – test and repair Go to Step C
		NO	Go to step B-2
2	Test continuity and connections of motor wire between control box and junction box.	YES	Continuity is good, motor is defective – replace
		NO	Repair wire as required and retest

D01 Continued on next page

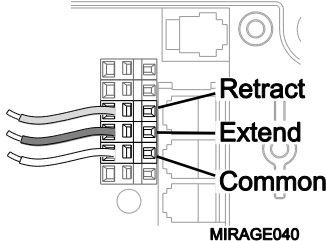
C	Test Touch Pad		
	1 Confirm 110VAC power to control box 1.1 Shut off power source. 1.2 Open control box. 1.3 On some early units a fuse is installed on the circuit board. Check that fuses on circuit boards are intact. 1.4 Check that 110VAC connections and splices to board is correct and secure. Refer to system schematic. 1.5 While observing the circuit boards, have power restored. The LEDs on the boards should blink red then green.	YES	Power is present; go to test B
		NO	Check vehicle circuits and fuses. Repair as required and retest
	2 Press the "Power On" button on the touch-pad. The "Power On" LED should illuminate.	YES	Power is on, go to step D-4
		NO	LED does not illuminate, go to step D-3
	3 Check the cable between the switch and control box. As a continuity check, Pin 1 of connector 1 goes to Pin 1 of connector 2; pin 2 goes to pin 2; pin 3 goes to pin 3 and pin 4 goes to pin 4.	YES	Continuity OK; go to step D-4
		NO	Replace cable and retest
	4 Check the function of the Touch pad 4.1 On the control board, locate the terminal strip next to the phone cord connectors. 4.2 Insert 3 wires into the terminals shown below 4.3 While observing the awning, short the wire ends between the Common and Extend terminals. Does the awning move? 4.4 Short the wire ends between the Common and Retract terminals. Does the awning move?	YES	Control Board is good, Touch pad is defective - replace
		NO	Control Board is defective – replace control box.
	 <p style="text-align: center;">MIRAGE040</p>		

D02 THE AWNING OPERATES DIFFERENTLY THAN THE SWITCH MARKINGS			
<i>This condition generally occurs during new installations or when major components have been replaced.</i>			
A	Does Awning operate in reverse of the switch plate labeling (i.e. extends when retract is pushed)?	YES	Motor wires from awning are reversed - locate motor wires in the control box, reverse the red and black wires.
		NO	

D03 AWNING DOES NOT AUTO-RETRACT IN WIND			
A	Press the power on button then press the auto-retract button. Does the auto-retract LED flash?	YES	The flashing LED indicates that the sensor has been disengaged or otherwise disabled. Go to step C.
		NO	Function does not work with switch; go to procedure D01
B	Confirm that the retract function works using the push buttons.	YES	Function works using the switch; go to test C
		NO	Function does not work with switch; go to procedure D01
C	Test Motion Sensor		
	1 Confirm cable is plugged into connector on box marked "Shaker"	YES	Go to step 2
		NO	Correct as required and test.
	2 2.1 Unplug sensor from control box. 2.2 Connect a second sensor into control box. 2.3 Set the control switches for the auto retract function 2.4 Hold the second sensor horizontally and gently move up and down.	YES	Awning retracts; original sensor defective - replace
NO		Awning does not retract; control box defective - replace	

DIAGNOSTIC TESTS – DIRECT RESPONSE FOR MULTIPLE AWNINGS

Refer to the Wiring Diagrams in the next section for wire and cable connections.

TESTING THE SYSTEM – MULTIPLE AWNINGS

All function buttons are press ON. The auto-functions continue until the awning is fully extended or retracted. Pressing the button a second time will stop the function. It is not necessary to hold the button while the function is active.

1. While observing the control panel, have a second person initiate 110VAC power to the coach and awning system. The following should occur:
 - 1.1 The Power ON/OFF and Wind Speed LEDs will briefly illuminate.
 - 1.2 The system then goes to the default settings: The POWER “ON”, AUTO-RETRACT “ON” and MEDIUM Wind Speed LED will be on.

NOTE: If the awnings operate from the touch pad but no LEDs are illuminated, check that the jumper cable between the controllers is plugged into AUX (motor #1) and ACC (motor #2).

2. Press the POWER “OFF”. ALL LEDs should be extinguished. The POWER ON/OFF button disables all functions including Auto-Retract and the optional RF remote. It does not disconnect the 110VAC power.
3. Check the extend function.
 - 3.1 Press the POWER “ON”.
 - 3.2 Press the Awning #1 EXTEND button. The awning should extend.
 - 3.3 Press the extend button again. The awning should stop
 - 3.4 Press the extend button a third time. Observe the awning, it should fully extend. The system performs an auto-tension action when the awning is fully extended. The awning rolls in reverse to tension the fabric. The auto-tension feature works only with the extend function when the awning is fully extended.
4. Check the retract function.
 - 4.1 Press the Awning #1 RETRACT button. The awning should retract.
 - 4.2 Press the retract button again. The awning should stop
 - 4.3 Press the retract button a third time. Observe the awning; it should fully retract to the closed position.

NOTE: If the awning moves in the opposite direction than the label, the red and black MOTOR wires are reversed in the control box.

5. Repeat steps 3 and 4 for each of the Extend/Retract button combinations.

NOTE: The Extend All and Retract All buttons should extend/retract all awnings.

6. Test the Auto-Retract function:
 - 6.1 Fully extend awning #1.
 - 6.2 Set the WIND SPEED to the lowest setting.
 - 6.3 Create a firm but gentle vertical rocking motion with the leading edge of the awning. The awning should retract after 2-3 seconds of the motion.
7. Repeat step 6 for each of the awnings.
8. *If the optional Ignition Sensor is installed:*
 - 8.1 Partially retract the awning.
 - 8.2 Turn the vehicle ignition key ON.
 - 8.3 Press the EXTEND button. The awning(s) should not extend.

In the charts below, YES is a positive response to the test; NO is a negative response.

D04 THE AWNING(S) OPERATE DIFFERENT THAN THE SWITCH MARKINGS			
<i>The power switch at the touch pad must be on; the LED will be illuminated if power is present.</i>			
A	Does a different awning move when pressing the controls are pressed (i.e. Awning #2 moves when Awning #1 is pressed)? Board marked "Motor 1" corresponds with touch pad "Awning 1" etc.	YES	Awning #Y moves when Awning #X buttons are pressed. - Awning motor wires from Awning #X and Awning #Y are reversed. Remove motor wires from control boards, reattach motor #X wires to motor #X control board; motor #Y wires to motor #Y control board.
		NO	Go to test B
B	Does the awning operate in reverse of the switch plate labeling (i.e. extends when retract is pushed)	YES	Motor wires from affected awning are reversed in control box. - Open control box and locate motor wires from affected awning. Reverse the red and black wires. NOTE: <u>For LH motor configurations:</u> RED WIRE goes to terminal RED (1); BLACK WIRE goes to terminal BLACK (1). <u>For RH motor configurations:</u> BLACK WIRE goes to terminal RED (1); RED WIRE goes to terminal BLACK (1).
		NO	Reanalyze condition

D05 THE AWNINGS DO NOT OPERATE (ALL)			
<i>For one awning that does not operate, refer to D03</i>			
A	Confirm 110VAC power to control box 5. Shut off power source. 6. Open control box. 7. On some early units a fuse is installed on the circuit board. Check that fuses on circuit boards are intact. 8. Check that 110VAC connections and splices to both boards are correct and secure. Refer to system schematic. 9. While observing the circuit boards, have power restored. The LEDs on the boards should blink red then green.	YES	Power is present; go to test B
		NO	Check vehicle circuits and fuses. Repair as required and retest
B	Confirm that touch-pad operating.		
1	Press the "Power On" button on the touch-pad. The "Power On" LED should illuminate.	YES	Power is on, go to step B-4
		NO	LED does not illuminate, go to step B-2
2	At bridge, disconnect cable then observe LED while plugging cable into "BUS" of bridge. LED should flash red then green.	YES	Power is present, go to step B-4
		NO	Go to step B-3
3	Check the cable between the bridge and control box. As a continuity check, Pin 1 of connector 1 goes to Pin 1 of connector 2; pin 2 goes to pin 2; pin 3 goes to pin 3 and pin 4 goes to pin 4.	YES	Continuity OK; go to step B-4
		NO	Replace cable and retest
4	4.1 Disconnect jumper cable between controller boards. 4.2 Disconnect touch-pad from "ACC" of controller #1 and connect to "ACC" of controller #2. 4.3 Does Awning #2 operate when pressing a command button on the touch pad?	YES	Awning operates, Controller #1 is defective – Replace control box.
		NO	Awning does not respond, touch-pad/bridge is defective - replace

D06 ONE AWNING DOES NOT OPERATE

NOTE: The awnings are programmed sequentially (i.e. #1, #2, #3, #4). If power is missing from an awning, the subsequent awnings will not function (i.e. #1 and #2 works, #3 and #4 don't) and the touch-pad LEDs do not illuminate. Check the power to the first non functioning control board in sequence (i.e. #3) and correct as necessary before proceeding.

A	<ol style="list-style-type: none"> Shut off power source if not already done. Open control boxes and disconnect the non-working awning motor wires and a working awning's motor wires. Connect the non-operating awning to the functioning control board (i.e. awning #2 to control board #1). Restore power Test the operation of the awning using the controls for the functioning awning (in the example above #1 awning). 	YES	Awning functions, control board of non-working awning is defective – replace control box.
		NO	Return wires to original configuration. Go to step B
B	Confirm awning motor is functioning		
	<ol style="list-style-type: none"> 1.7 With power off, connect awning motor directly to 110VAC power source. White = Hot Green = Ground Red & Black are Motor Direction Control – connect one 1.8 Briefly apply power. 1.9 Does awning move when power is applied? 	YES	Awning motor is good, control box is defective - replace
		NO	Go to step B-2
	<ol style="list-style-type: none"> 2. Test continuity and connections of motor wire between control box and awning motor. 	YES	Continuity is good, motor is defective – replace
		NO	Repair as required and retest

D07 AWNING(S) DO NOT RETRACT DURING WINDY CONDITIONS

The Direct Response auto-retract system operates by gauging the motion of the awning's leading edge, not by the direct wind speed. Refer to the description in the operations section of the manual.

NOTE: The awnings have independent sensors and may not retract concurrently.

A	Press the power on button then press the auto-retract button. Do the auto-retract LED flash?	YES	The flashing LED indicate that the sensor(s) have been disengaged or other wise disabled. Go to step C
		NO	Go to test B
B	Confirm standard awning operation. From the touch-pad, operate the awnings.	YES	Operation is normal, Go to step C
		NO	Refer to the appropriate test D02 or D03
C	<ol style="list-style-type: none"> Check function of shaker sensor Open the affected awning (does not have to be open all the way). Open the second awning. Open control box and disconnect sensor from controller board of awning that does not auto-retract. If cable has been spliced between sensor and control box, check continuity of splice. Repair as required and retest before proceeding. Disconnect the sensor from the other controller and plug the cable into the "SHAKE" terminal of the affected awning controller. At touch-pad, turn power ON and auto-retract ON. Set auto-retract to the lowest setting. At the unaffected awning, create a firm but gentle rocking motion with the leading edge of the awning for about 3-4 seconds. 	YES	The affected awning retracts. Original sensor is defective replace. Return second shaker to the unaffected awning controller.
		NO	Awning does not retract, control box is defective – replace

NOTE: The touch pad LEDs will continue to flash after connecting good sensors. It is necessary to power off the system then turn it back on so that the touch-pad recognizes the sensors are connected

D08 AWNING DOES NOT MOVE WHEN REMOTE CONTROL BUTTONS ARE PUSHED			
	1. Confirm power is ON at the touch-pad	--	Correct as required
	2. Confirm batteries in remote are good. Pressing any button on the remote will illuminate the LED at the top of the remote.		Replace as needed
	3. Check the cable between the Receiver and control box. As a continuity check, Pin 1 of connector 1 goes to Pin 1 of connector 2; pin 2 goes to pin 2; pin 3 goes to pin 3 and pin 4 goes to pin 4. Cable must be plugged into the "BUS" port of controller #1.	YES	Cable is OK. Confirm that cable is securely plugged in; go to step 4
		NO	Repair or Replace cable as required.
	4. Confirm that the Receiver is programmed for the Remote	--	Refer to "Programming the Receiver" on page 5 and retest. If system does not work; go to step 5
	5. Program a second remote and test	YES	2 nd remote works. 1 st remote is defective.
		NO	2 nd remote does not work; go to step 6
	6. Replace the Receiver and test. (it will be necessary to program receiver for remote)	YES	System works OK. 1 st receiver is defective
		NO	System does not work. Reinstall 1 st receiver; go to step 7
	7. Replace control box	--	

ELECTRONICS



! WARNING

Shock Hazard. Always disconnect battery or power source before working on or around the electrical system.

IMPORTANT NOTICES

- Failure to follow the wiring instructions in this publication may void the warranty.
- All wiring must conform to NEC (National Electrical Code) and local codes.
- DO NOT wire two or more motors to one motor controller.
- The SO cable from the 110VAC awning motor can only pass directly through a wall, it cannot be laid up in the wall and must be connected to NM wire or individual wires in conduit no more than 6 inches past the point of entry.
- The installer must provide enclosed junction boxes for all 110VAC wire splices. Boxes are required in conformance with prevailing construction codes. Installers are required to furnish the UL approved electrical boxes where required.
- At the control box location, AC input is required. It is recommended that the installer provide a dedicated AC circuit for the awning system that is protected by an appropriate sized fuse/circuit breaker. Each patio awning draws a maximum of 3 amps.
- The motion sensor for the *Direct Response* system is mounted on the patio awning. 10 feet cable is available from the awning wall mount, and will require a routing path to the control box. If the control box is located at a distance greater than 10 feet, the installer must provide a terminated jumper cable from the box location to the cable end.
- Terminated cable is a 4-wire RJ11 terminated phone cord (straight, no twist).

The 110V electronic control system provides the user with simple pushbutton controls for the awnings installed. Three configurations are available:

1) Direct Response for Single Awning Installations.

- System includes: Control box (single control board), Master control panel (w/ pushbutton awning control and windspeed sensitivity settings), motion sensor; and, an RF remote control.
- An optional ignition lockout is available.

2) Direct Response for Dual Awning Installations.

- System includes: Control box (2 control boards), Master control panel (w/ touchpad awning control and windspeed sensitivity settings), motion sensors; and, an RF remote control i.
- An optional ignition lockout is available.

3) Direct Response for Dual Awning Installations.

- System includes: 2-Control box (2 control boards each), Master control panel (w/ touchpad awning control and windspeed sensitivity settings), motion sensors; and, an RF remote control i.
- An optional ignition lockout is available.

The switches use a 5VDC signal to operate the control box; thus eliminating the need for a junction box for the control panel.

Electronic components are connected using terminated cables. Terminated cable is 4-wire RJ11 terminated phone cord (straight, no twist). This does not include 110VAC power in or awning motor power.

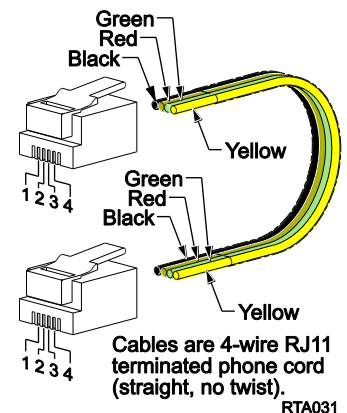

WIRING DIAGRAM – SINGLE AWNING

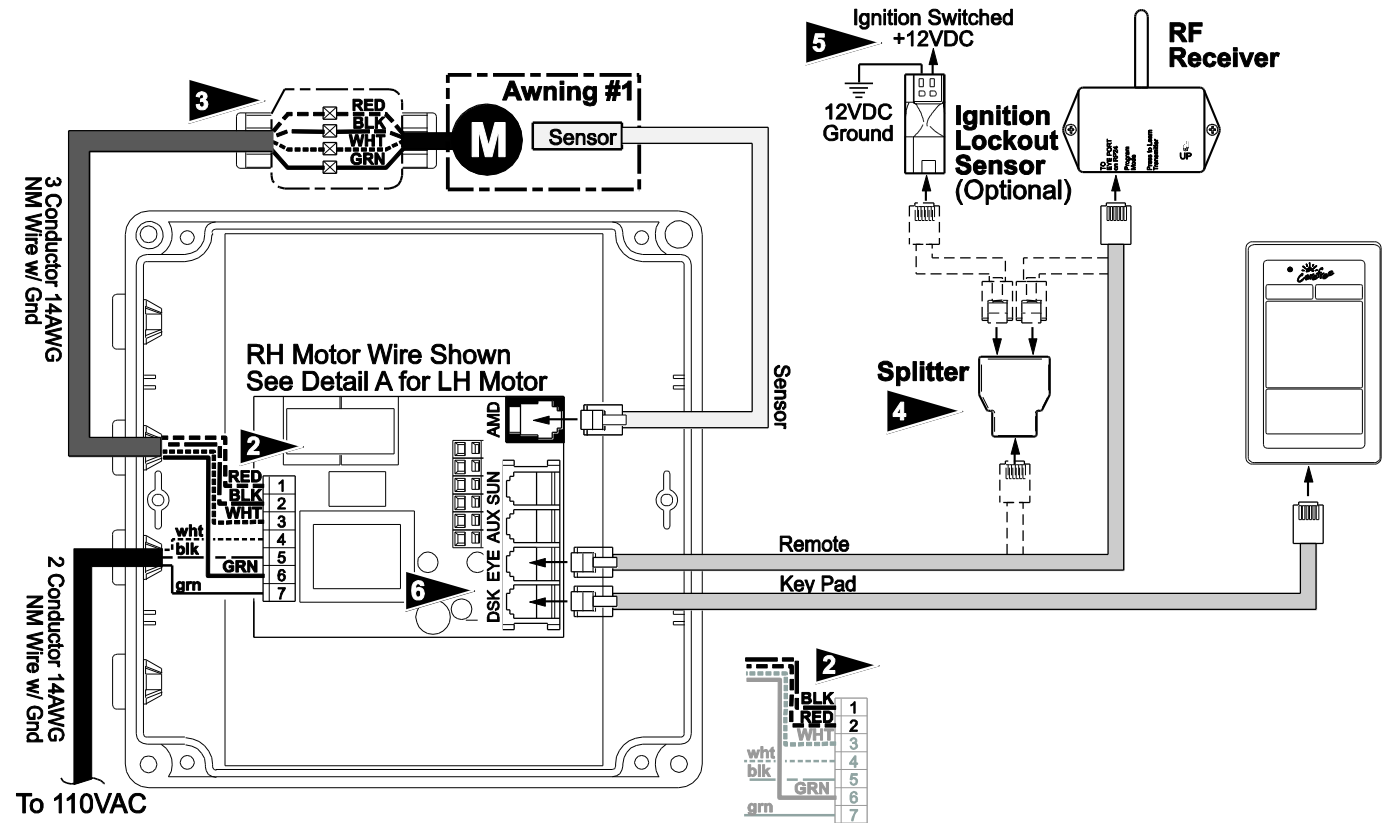

NOTES:

- 1** Wire Legend:
 - Red
 - Black
 - White
 - Green (Ground)
- 2** For RH Motor Configurations: Motor Red goes to Pin (1); Motor Black goes to Pin (2)
 For LH Motor Configurations: Motor Red goes to Pin (2) Black; Motor Black goes to Pin (1)
- 3** The SO cable from the 110VAC awning motor can only pass through a wall, it cannot be laid up in the wall and must be connected to NM wire or individual wires in conduit no more than 6 inches past the point of entry.
- 4** Splitter is used only when Optional Lock-Out Sensor is installed. Connect RF Receiver directly to "EYE" if Lock-Out is not installed.
- 5** Wires for the Ignition Lock-Out Sensor are not pin specific.

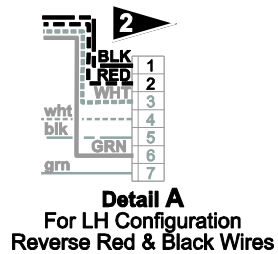

DR012a

FROM		To (RH CONFIGURATION)		To (LH CONFIGURATION)	
Motor	Black	Control Box	1	Control Box	2
	Red		2		1
	White		3		3
	Ground		6		6
AC Power Source	White	Control Box	4	Control Box	4
	Black		5		5
	Ground		7		7
Awning Sensor	10' Cable	Control Box	"AMD"	Control Box	"AMD"
Key Pad	60" Cable	Control Box	"DSK"	Control Box	"DSK"
Splitter	60" Cable	Control Box	"EYE"	Control Box	"EYE"
RF Receiver	60" Cable	Splitter		Splitter	
Ignition Lockout	60" Cable	Splitter		Splitter	

Notes: 1. Cable lengths are the lengths of the furnished cables. If a connection requires a length greater than the supplied cable, the installer must provide a terminated jumper cable from the box location to the cable end.

WIRING DIAGRAM – 2-AWNINGS

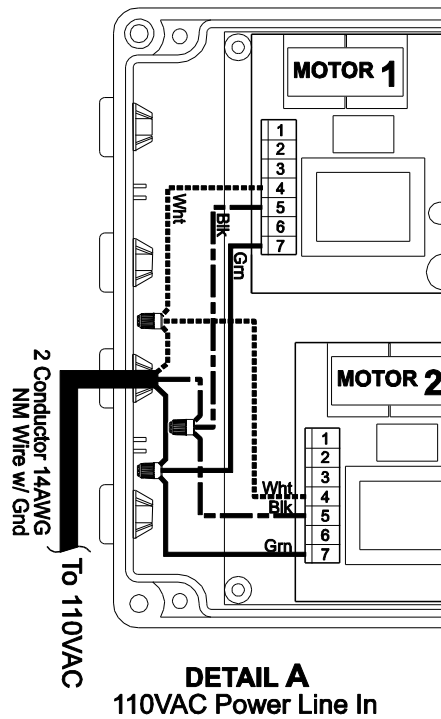
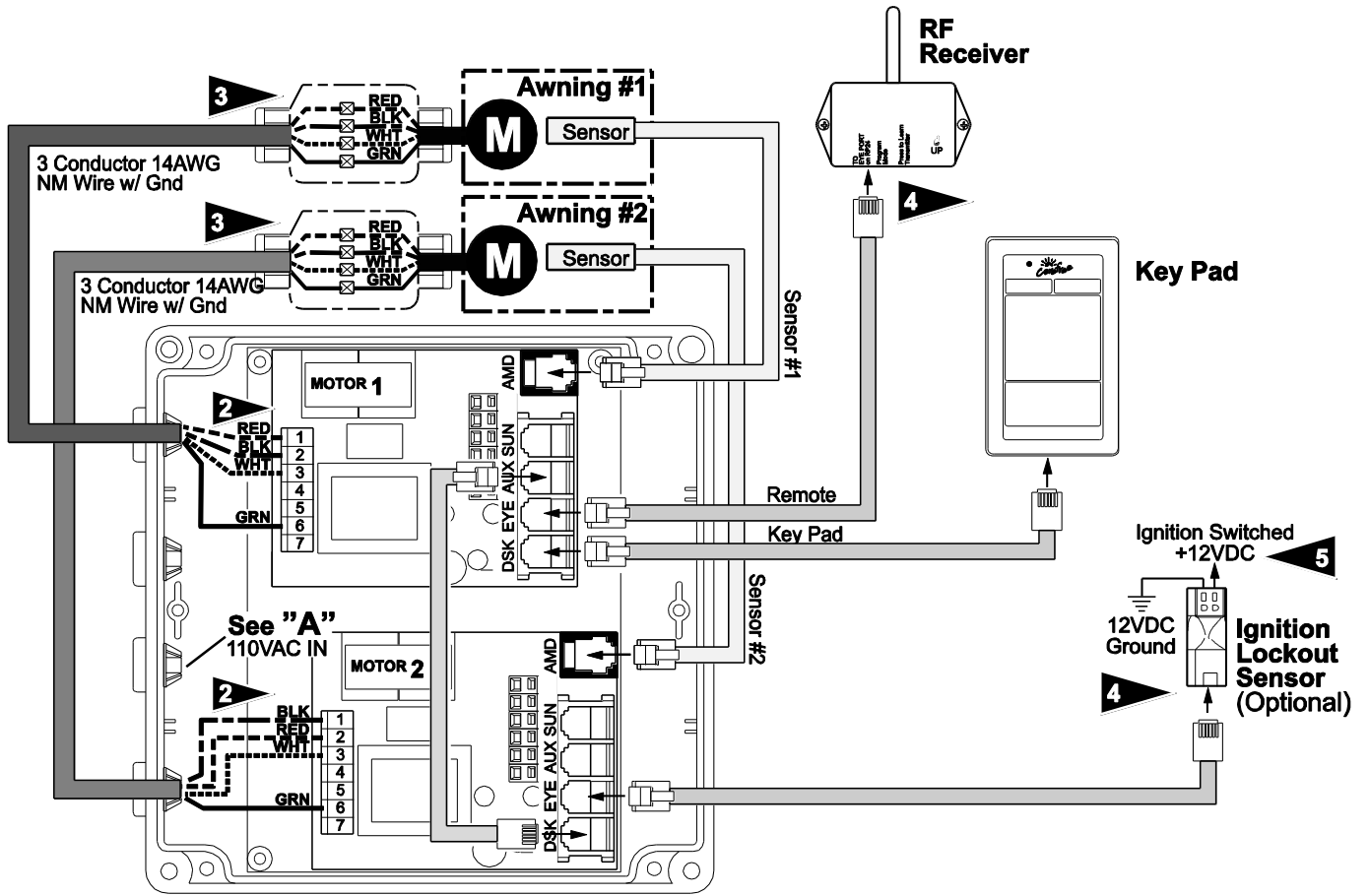

DR014a

NOTES:

- 1 **Wire Legend**
- Red
 - Black
 - White
 - _____ Green (Ground)

- 2 **Awning #1 shown as LH Motor, Awning #2 shown as RH Motor**
- For LH Motor Configurations:**
 Motor Red goes to Pin (1); Motor Black goes to Pin (2)
- For RH Motor Configurations:**
 Motor Red goes to Pin (2); Motor Black goes to Pin (1)

- 3 The SO cable from the 110VAC awning motor can only pass directly through a wall; it cannot be laid up in the wall and must be connected to NM wire or individual wires in conduit no more than 6" past the point of entry.

- 4 The RF Receiver and the optional Ignition Lockout may be plugged into any open "EYE" port.

- 5 Wires for Ignition Lock-Out Sensor are not pin specific.

- 6 For screw type terminals: After testing connections, use Loctite 29005 or equivalent to secure screws in terminal block

- 7 Cables are 4-wire RJ11 terminated phone cord (straight, no twist).

- 8 Terminal block designations are for reference only. Actual boards may not be marked.

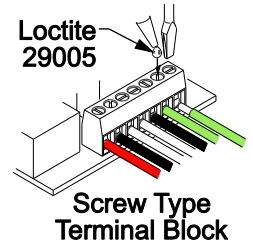

FROM		TO CONTROL BOARD		
		MOTOR #1	MOTOR #2	
AC Power Source	White	4	4	
	Black	5	5	
	Ground	7	7	
Awning #1 Motor	Black	Refer to Flag Note 2		
	Red			
	White			3
	Ground			6
Awning #2 Motor	Black		Refer to Flag Note 2	
	Red			
	White			3
	Ground			6
#1 Sensor	10' Cable	"AMD"		
#2 Sensor	10' Cable		"AMD"	
Key Pad	25' Cable	"DSK"		
RF Receiver	60" Cable	"EYE" see note 4		
Ignition Lockout	60" Cable	"EYE" see note 4		

WIRING DIAGRAM – 4 AWNINGS

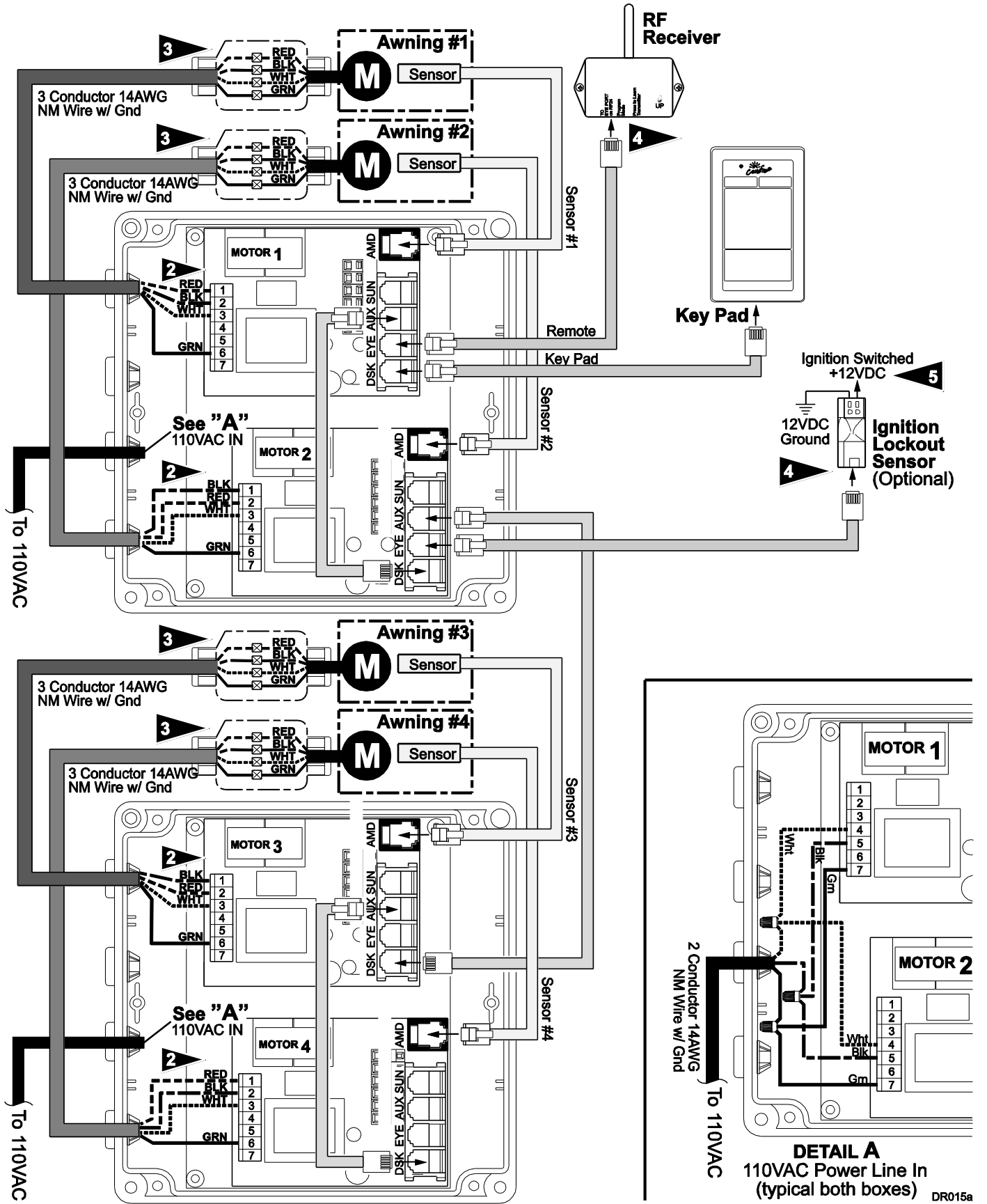

NOTES:

- 1  Wire Legend
 - Red
 - Black
 - White
 - Green (Ground)

- 2  Awnings #1 & #4 shown as LH Motor, Awnings #2 & #3 shown as RH Motor

For LH Motor Configurations:

Motor Red goes to Pin (1); Motor Black goes to Pin (2)

For RH Motor Configurations:

Motor Red goes to Pin (2); Motor Black goes to Pin (1)

- 3  The SO cable from the 110VAC awning motor can only pass directly through a wall; it cannot be laid up in the wall and must be connected to NM wire or individual wires in conduit no more than 6" past the point of entry.

- 4  The RF Receiver and the optional Ignition Lockout may be plugged into any open "EYE" port.

- 5  Wires for Ignition Lock-Out Sensor are not pin specific.

- 6  For screw type terminals: After testing connections, use Loctite 29005 or equivalent to secure screws in terminal block

- 7  Cables are 4-wire RJ11 terminated phone cord (straight, no twist).

- 8  Terminal block designations are for reference only. Actual boards may not be marked.

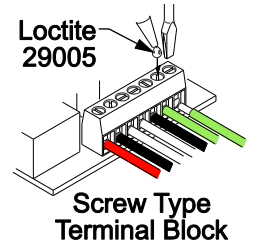

FROM		TO CONTROL BOARD				
		MOTOR #1	MOTOR #2	MOTOR #3	MOTOR #4	
AC Power Source	White	4	4	4	4	
	Black	5	5	5	5	
	Ground	7	7	7	7	
Awning #1 Motor	Black	Refer to Flag Note 2				
	Red					
	White					3
	Ground					6
Awning #2 Motor	Black		Refer to Flag Note 2			
	Red					
	White		3			
	Ground		6			
Awning #3 Motor	Black			Refer to Flag Note 2		
	Red					
	White			3		
	Ground			6		
Awning #4 Motor	Black				Refer to Flag Note 2	
	Red					
	White				3	
	Ground				6	
#1 Sensor	10' Cable	"AMD"				
#2 Sensor	10' Cable		"AMD"			
#3 Sensor	10' Cable			"AMD"		
#4 Sensor	10' Cable				"AMD"	
Key Pad	25' Cable	"DSK"				
RF Receiver	60" Cable	"EYE" see note 4				
Ignition Lockout	60" Cable	"EYE" see note 4				

CONNECTION FLEX w/ "110VDR" CONTROL BOXES

The wiring diagrams show the standard installation for multiple awning configurations. For control boxes marked w/ "110VDR", the installer may adjust the cable interconnections for greater flexibility during installation.

1. The key pad may be installed in the unused DSK port of any board with the jumper cables sequentially connected from the AUX port to the DSK port of the next board.

Example: Placing the keypad in the DSK of Board 3.

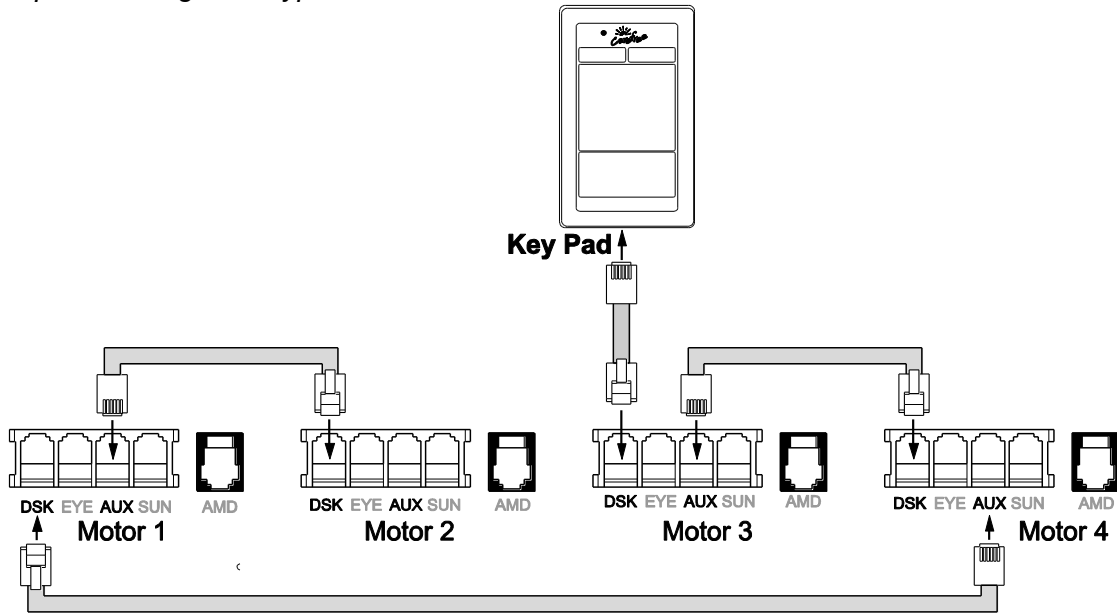

DR024

2. The RF Receiver and the optional ignition lock-out can be plugged into any unused "EYE" port. It is not necessary to use the splitter as shown in the diagrams.
3. The "110VDR" control boxes are compatible with integrator interfaces. Contact Carefree engineering for information and system requirements.

OPTIONAL MANUAL BYPASS SWITCH

Installers may elect to install a manual bypass switch for testing or emergency operation of the awning. The simple switch allows the operator to extend or retract the awning without using the keypad control panel. For multiple awning installations, a separate switch must be installed for each awning.

1. Open the control box and identify the terminal block next to the phone cord jacks.
2. Connect the switch to the terminal block as shown in the diagram.

The switch is a single pole, double throw, momentary ON, center OFF. Components are installer furnished.

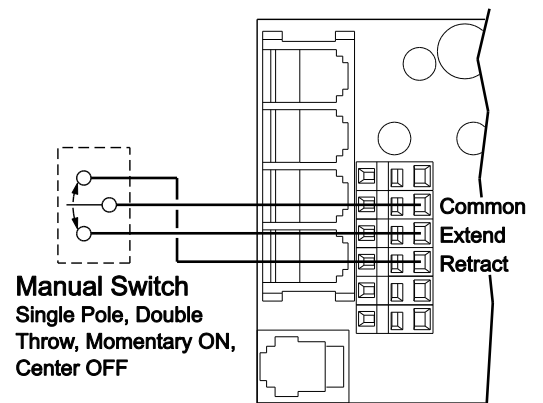

DR011

SENSOR REPLACEMENT FOR DIRECT RESPONSE

NOTE: Sensors must be mounted vertically as shown and will not work properly if mounted horizontally.

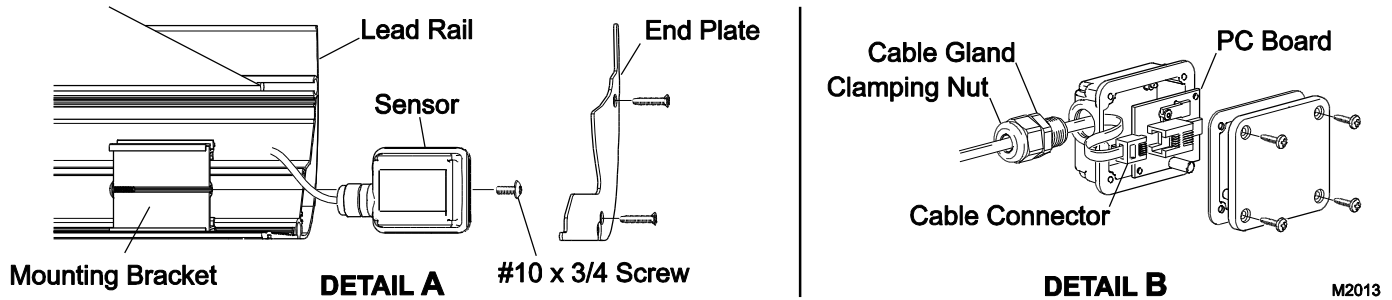

The replacement sensor is furnished with a 25 foot cable. The cable is furnished in case the installed cable has been damaged or compromised.

NOTICE Do NOT attempt to cut and splice the cable. If damaged, the cable must be replaced to ensure system integrity.

REMOVING THE OLD SENSOR

1. Remove the lead rail endplate. Set parts aside to reuse.
2. Remove the #10 x 24 screw from the sensor bracket and slide the sensor assembly out of the bracket.
3. Test the cable integrity:
 - 3.1. After detaching the sensor from the lead rail, loosen the clamping nut on the wire gland.
 - 3.2. Unscrew the wire gland from the sensor case and slide down the wire and out of the way.
 - 3.3. Remove the back of the sensor case to reveal the PC board.
 - 3.4. Carefully remove the board from the case. In some instances, the board may be tacked with adhesive and must be pried out. Use care to not damage the cord or connector.
 - 3.5. Disconnect the cable from the board and slip the connector out of the sensor case.
 - 3.6. Test the continuity of the installed cable. Several cable testers are commercially available. If the cable is faulty, go to "Replacing a Sensor and Cable". If the cable is OK go "Installing a Sensor Only".

REPLACING A SENSOR AND CABLE

1. Remove the existing cable. Pay particular attention to the routing and attachment points of the existing cable.
2. Slide the new sensor into the vertical mounting bracket and secure with a #10 x 3/4 screw as shown.
3. Route the new cable and sensor to the control box. Arch the cable slightly at the arm joints to avoid binding.

INSTALLING A SENSOR ONLY:

1. On the new sensor, loosen the clamping nut on the wire gland.
2. Unscrew the wire gland from the sensor case and slide down the wire.
3. Remove the back of the sensor case to reveal the PC board.
4. Carefully remove the board from the case.
5. Disconnect the cable from the board and slip the connector out of the case.
6. Slide the connector of the installed cable into the new sensor case.
7. Attach the wire gland to the case. Do not tighten the clamping nut at this time.
8. Attach the cable to the new board.
9. Reassemble the new sensor.
10. Tighten the cable gland clamping nut.
11. Slide the new sensor into the vertical mounting bracket and secure with a #10 x 3/4 screw as shown.

STANDARD MAINTENANCE

Maintaining a Carefree Awning is easy. Just follow these basic steps:

- Always operate the awning according to the instructions.
- Periodically check that the fasteners are tight. Tighten if necessary.
- Keep the awning fabric and arms clean.

FABRIC CARE

NOTICE Do not use oil based cleaners or any caustic, granulated, or abrasive type cleaners on your Carefree product.

1. One of the best ways to keep the fabric looking good and to delay the need for deep or vigorous cleanings is to hose fabrics off on a monthly basis with clear water. This practice will help prevent dirt from becoming deeply imbedded in the fabric. In most environments, a thorough cleaning will be needed every two to three years.
2. When it's time for a thorough cleaning, the fabric can be cleaned while still on the awning frame. For Acrylic Fabric – Use a stiff brush and warm water with soap.
3. When cleaning the fabric, it is important to observe the following:
 - Always use a natural soap, never detergent.
 - Water should be cold to lukewarm, never more than 100°F.
 - Air-dry only. Never apply heat to the fabric.
 - Always allow the fabric to dry thoroughly before rolling up the awning.

Mildew

Mildew is a fungus growth that looks like dirt. Vinyl coated polyester fabrics are mildew resistant because of a chemical biocide in the vinyl coating. Under ordinary conditions, mildew will not appear. However, in areas where high temperature and humidity are common, mildew can be a problem and required the material to be washed more frequently. Thoroughly rinse the fabric with clean water and allow to air dry completely before rolling up the awning.

Pooling

When water collects on the top of the fabric, this is known as "pooling". This can occur during inclement weather or if a running air conditioner discharges over the awning. The water is dumped when the awning is retracted. It is recommended that if water accumulates on the top; retract the awning in steps (8"-12") to dump the water. This will help prevent the fabric from stretching or distorting.

The effects of wind and rain on an awning are unpredictable. Severe damage to the awning and the vehicle may result. IF WIND OR EXTENDED PERIODS OF RAIN ARE EXPECTED, ROLL UP THE AWNING AND SECURE FOR TRAVEL.

ARM CARE

The best method of keeping the arms and braces operating smoothly is to clean them. Dirt and debris can cause the channels not to slide easily.

Periodically wash out the channels with running water (i.e. a hose) to keep them clean. If the channels still do not slide easily, lightly spray the joints and/or inside of the channels with a dry silicone lubricant, after the arms have been cleaned and dried thoroughly.

Hardware Maintenance

- Replace any parts that become damaged.
- Periodically check all mounting hardware, screws, lags, etc., and re-tighten when necessary.

MOTOR MAINTENANCE

- Check all wiring and connections for wear. Repair when needed.
- Check that the sealant is providing a good seal and no water is accumulating on the wiring.

PART NUMBER LISTING

PART NUMBER/SERIAL NUMBER LOCATION



ILLUSTRATED PARTS LIST



VS Configuration
Canopy construction with vertical seams (previous)

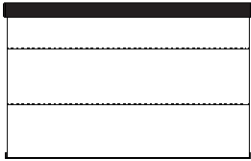

HS Configuration
Canopy construction with horizontal seams (current)

There are two configurations of the Mirage identified by the canopy construction shown above.

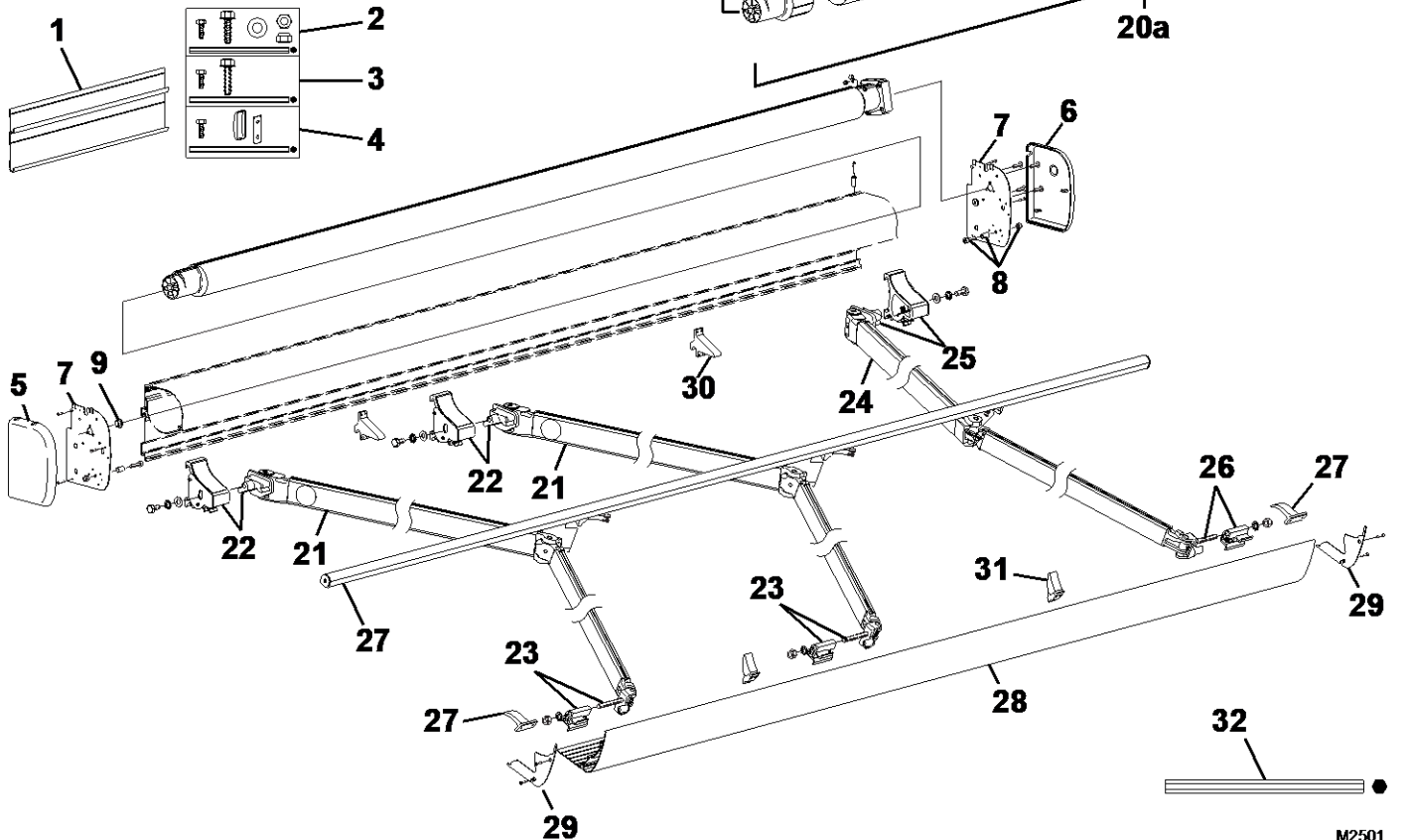
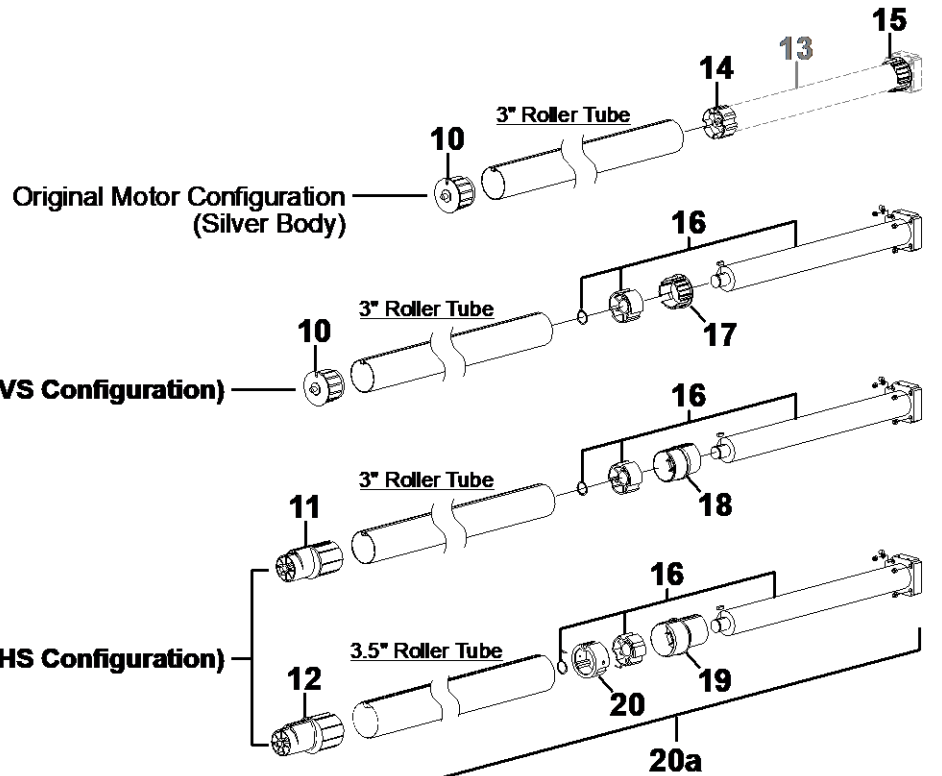

M2501

Item	Part Number	Description	Notes
1	R035468-001	Mounting Bracket	Pkg of 1
2	R001765	Hardware Pack, Roof Mount	2
3	R001766	Hardware Pack, Wall Mount	3
4	R001767	Hardware Pack, Through Wall	4
5	R040876-00X	End Cap, LH	7
6	R040875-00X	End Cap, RH	7
7	R036618-JV1	End Plate, Housing	
8	R001768	Lead Rail Guide Post Kit	
9	R035310-002	Bushing, Idler	
10	R001054	End Plug, Idler	Used with VS Configuration 3" Roller Tube
11	R041335-001	End Plug, Idler	Used with HS Configuration 3" Roller Tube
12	R041581-001	End Plug, Idler	Used with HS Configuration 3.5" Roller Tube
13	NLA	Motor Assy, Silver Body	Discontinued FSO R001853
14	R030886-001	Drive Gear, Motor	Used with item 13
15	R030885-001	Crown, Motor	Used with item 13
16	R001853	Motor Assy, Orange Body	6
17	R041369-001	Crown, Motor	Used with VS Configuration 3" Roller Tube
18	R041336-001	Crown, Motor	Used with HS Configuration 3" Roller Tube
19	R041580-001	Crown, Motor	Used with HS Configuration 3.5" Roller Tube
20	R001992-001	Drive Adaptor	Used with HS Configuration 3.5" Roller Tube
20a	R001980	Roller Tube Upgrade Kit	with fabric 10
	R001980X	Roller Tube Upgrade Kit	without fabric 10
21	R012598-23L115	Spring Arm Assy, LH and Center, Mill	7
	R012598-JVL115	Spring Arm Assy, LH and Center, Black	7
22	R019260-101	Case Connector, LH and Center, Mill	7
	R019260-JVL	Case Connector, LH and Center, Black	7
23	R019366-23L	Lead Rail Connector, LH	7
24	R012598-23R115	Spring Arm Assy, RH, Mill	
	R012598-JVR115	Spring Arm Assy, RH, Black	
25	R019260-001	Case Connector, RH, Mill	
	R019260-JVR	Case Connector, RH, Black	
26	R019366-23R	Lead Rail Connector, RH	
27	R001769xxx	Middle Rail Assy	
28	R001770XXX-xxx.xx	Lead Rail	
29	R036609-00X	End Plate, Lead Rail	
30	R001812	Ramp Block, Mid Rail Lift	
31	R001813	Ramp Block Kit, Lead Rail Lift	5
32	R030796-001	Hex Key, Manual Override, 7mm	

- Notes:
- 00X = Color; -005 = White, -006 = Black
 - Hardware pack (item 2) contains 24 ea 3/8-16 x 1.25 flange head screw, nylock nut and washer; 4 ea 1/4-20 x .75 thread forming screws.
 - Hardware pack (item 3) contains 24 each 3/8 x 1.5" Rolock screws; 4 ea 1/4-20 x .75 thread forming screws.
 - Hardware pack (item 4) contains 4 ea 1/4-20 x .75 thread forming screws; 6 ea backing plate and cover.
 - Ramp Block Kit (item 27), Awnings under 18' uses one kit, awnings over 18' uses two kits.
 - Motor assembly (item 15) includes drive, crown (item 16) and attaching hardware. It does not include crown (item 17).
 - Center arm is used on units 18' and longer.
 - On units built prior to 04/2017 it is recommended that if replacing an endcap, replace both endcaps for improved appearance.
 - Starting in March, 2019 Carefree uses a 3.5" aluminum roller tube. Prior units used a 3" steel roller tube. Confirm the awning configuration and roller tube diameter before ordering parts.
 - A roller tube upgrade kit (item 20a) is available to upgrade existing awnings with the current roller tube configuration. Kit includes roller tube, motor, drive adaptor, crown, end plug and fabric. To order you must specify the product, nominal product length, canopy type and motor install side (LH or RH).

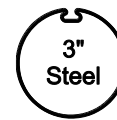

Paramount040

Electronics

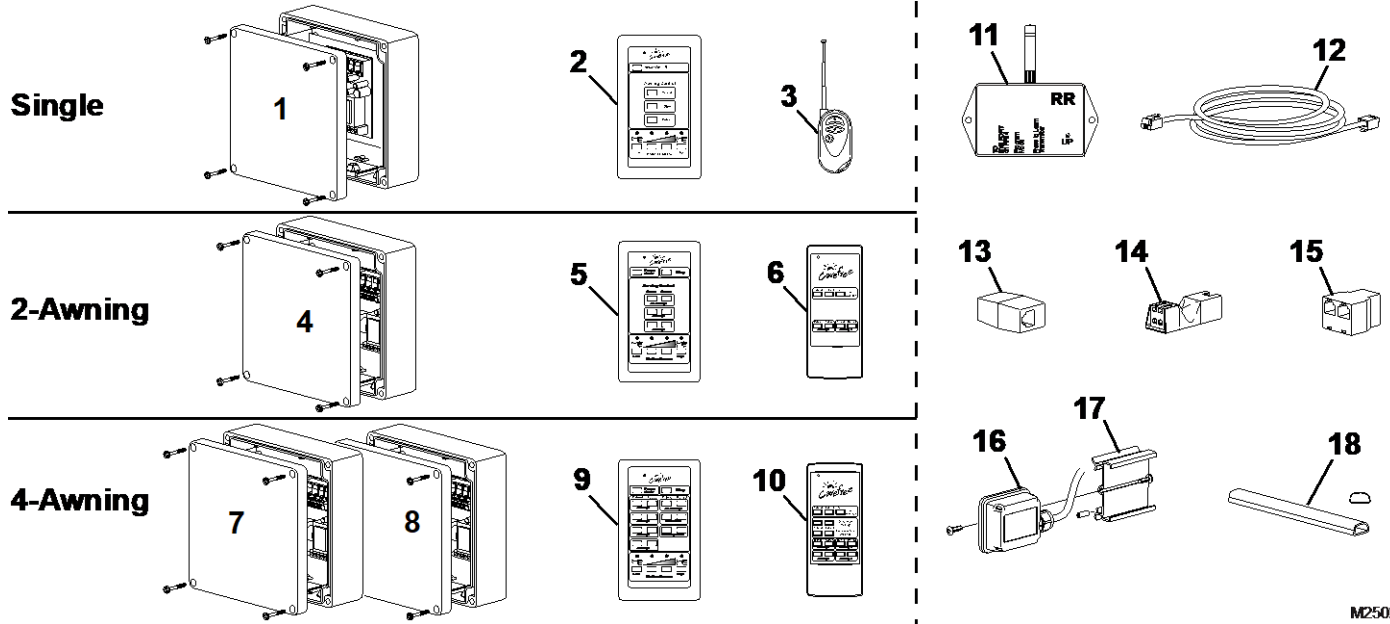

M2502

Item	Part Number	Description	Notes
1	R060633-001	Control Box 110VDR	Single Awning
2	R060616-102	Key Pad	Single Awning
3	R060622-001	Key FOB, Remote, 433 MHZ, Version 2	Single Awning
4	R060633-002	Control Box, Motor 1 & 2 110VDR	2-Awning
5	R060616-202	Key Pad	2-Awning
6	R001393	Remote w/ Stop, 433 MHz	2-Awning
7	R060633-002	Control Box, Motor 1 & 2 110VDR	4-Awning
8	R060633-004	Control Box, Motor 3 & 4 110VDR	4-Awning
9	R060616-402	Key Pad	4-Awning
10	R001394	Remote w/ Stop, 433 MHz	4-Awning
11	R060429-003	RF Remote Receiver, 433 MHz	
12	R060434-001	Phone Cable, 60"	
	R060434-008	Phone Cable, 240"	
13	R060596-001	Coupler, Cable	
14	R060532-001	Ignition Lockout Sensor	
	R060532-002	Ignition Lockout Sensor, RTL	
15	R060589-001	Splitter	
16	R060538-002	Motion Sensor w/ cable	
17	R001355	Bracket Kit, Vertical Sensor Mount	
18	R040616-206	Cable Channel	

Notes: 1. Control boxes, switches and remotes are NOT interchangeable between systems.

For LED replacement parts and service procedures refer to 070013-301 "LED Service Manual for Box Awnings" available on-line at www.carefreeofcolorado.com