



INSTALLATION MANUAL

MIRAGE 2-STAGE

Product style code: DL

RV

with Direct Response Electronics



Read this manual before installing or servicing this product. Failure to follow the instructions and safety precautions in this manual can result in personal injury and/or cause the product to not operate properly.



TABLE OF CONTENTS

Product Overview	1
Specifications	1
Component Checklist.....	2
Installation – Mechanical	4
Required Pre-Installation Parameters	4
Mounting Plate Layout and Installation	5
Mounting Height	5
Alternate Mounting Plate Attachment Method	7
Mounting the Awning Unit.....	7
Securing the Awning.....	7
Electrical Installation	8
Key Pad Installation	8
Control Box Installation	9
Installing the Remote Receiver	10
Ignition Lockout Sensor Installation (Optional)	11
Wiring Diagram – Single Awning.....	12
Wiring Diagram – 2-Awnings	13
Wiring Diagram – 4 Awnings.....	15
Connection Flex w/ "110VDR" Control Boxes	17
Optional Manual Bypass Switch.....	17
Optional LED Lighting Switch Installation.....	18
Testing the System	19
Standard System Adjustments	20
Adjusting the Pitch	20
Manual Override	20
Setting the Motor Limits	21

PROPRIETARY STATEMENT

The Mirage 2-Stage Patio Awning is a product of Carefree of Colorado, located in Broomfield, Colorado, USA. The information contained in or disclosed in this document is considered proprietary to Carefree of Colorado. Every effort has been made to ensure that the information presented in the document is accurate and complete. However, Carefree of Colorado assumes no liability for errors or for any damages that result from the use of this document.

The information contained in this manual pertains to the current configuration of the models listed on the title page. Earlier model configurations may differ from the information given. Carefree of Colorado reserves the right to cancel, change, alter or add any parts and assemblies, described in this manual, without prior notice.

Carefree of Colorado agrees to allow the reproduction of this document for use with Carefree of Colorado products only. Any other reproduction or translation of this document in whole or part is strictly prohibited without prior written approval from Carefree of Colorado.

SAFETY INFORMATION



This is the safety alert symbol. It is used to alert individuals to potential personal injury hazards. Obey all safety messages that follow this symbol to avoid possible personal injury or death.



Indicates a hazardous situation, which if not avoided, could result in death or serious bodily injury.



Indicates a hazardous situation, which if not avoided, may result in minor or moderate bodily injury.



Indicates a situation that may result in equipment-related damage.

General Safety:



This product can expose you to chemicals including Di-isodecyl phthalate (DIDP), Vinyl Chloride and Formaldehyde, which are known to the state of California to cause cancer or birth defects or other reproductive harm. For more information visit www.P65warnings.ca.gov



Shock Hazard. Always disconnect battery or power source before working on or around the electrical system.



Always wear appropriate safety equipment (i.e. goggles).



Always use appropriate lifting devices and/or helpers when lifting or holding heavy objects.



When using fasteners, do not over tighten. Soft materials such as fiberglass and aluminum can be "stripped out" and lose the ability to grip and hold.

Electric components in this product have been tested by the following agencies:



Motor: UL Recognized (USA)
CSA Approved (Canada)
Controls: UL Listed (USA & Canada)



PRODUCT OVERVIEW

The Mirage 2-Stage Patio Awning offers the coach owner an awning system that provides as much or as little shade as required. The canopy is housed in an aluminum case that easily blends in with the coach roof.

Each unit is equipped with lateral support arms that are the strongest available on the market. No vertical arms interfere with coach sidewalls or equipment that may be mounted on the roof.

Carefree's 110V *Direct Response* system provides interior pushbutton controls for standard extend/retract functions. At the master control panel the auto-retract system can be engaged to automatically retract the awning in windy conditions. Sensitivity can be set to respond to a variety of wind speed conditions. An RF remote is available with the *Direct Response* system.

Specifications

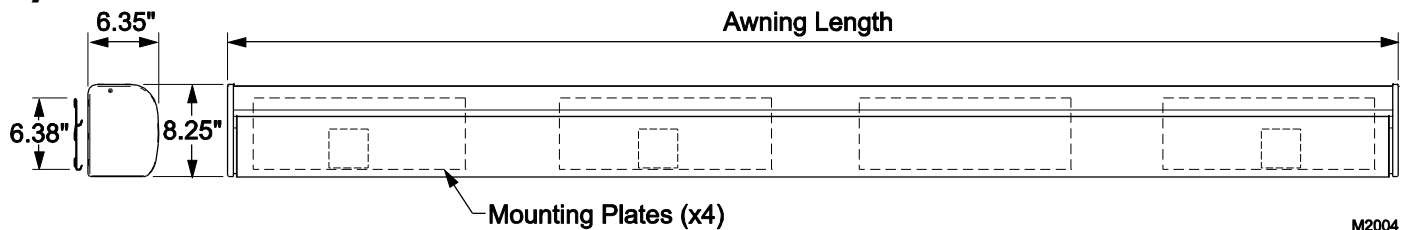

LENGTHS:	12' – 21'	
EXTENSIONS:	10' (standard)	
COLORS AVAILABLE:	Case:	Black
	Fabric:	Woven Acrylic Fabric refer to order form for available colors
MOTOR SPECIFICATIONS:	Available in LH or RH configurations	
Type:	Tubular Motor	
Power:	120V, 60HZ, 2.5A	
Torque:	60 nm	
Speed:	14 RPM	
Cycle:	40 Sec ON / 1 Min OFF	

COMPONENT CHECKLIST

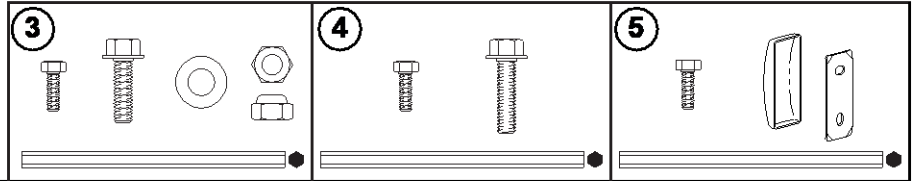
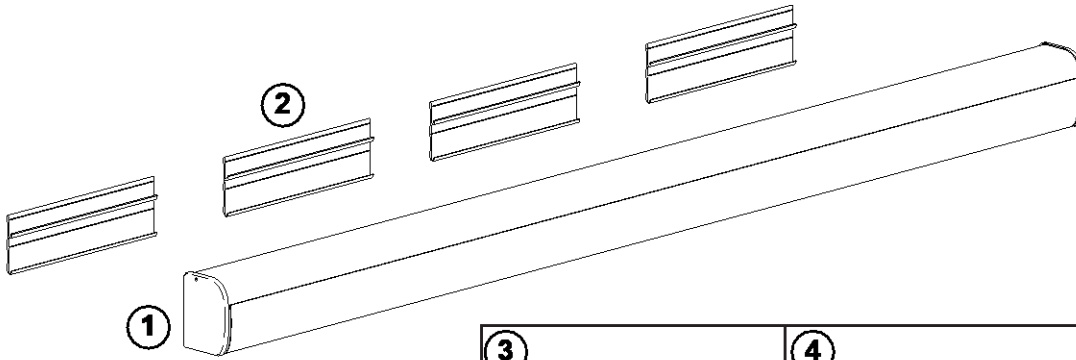

Single Awning Electronics

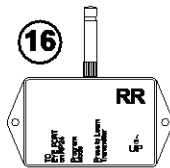
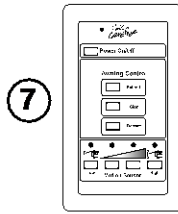
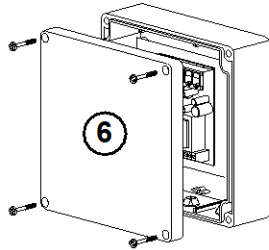

Dual Awning Electronics

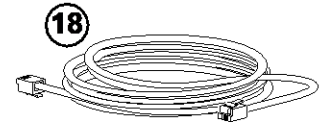
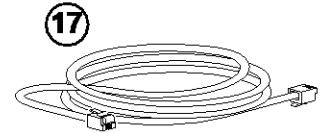
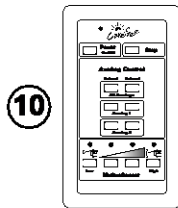
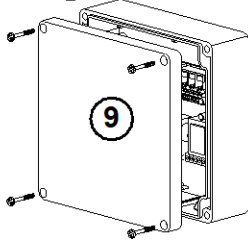

4-Awning Electronics

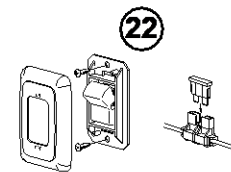
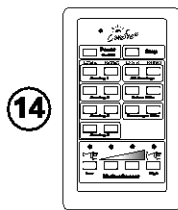
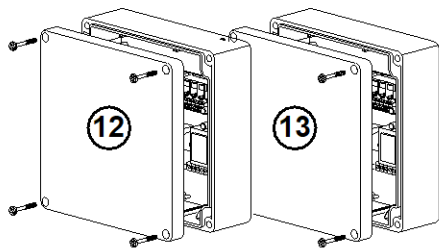

M2003

U	ITEM	DESCRIPTION		QTY	NOTE
<input type="checkbox"/>	1	Mirage 2-Stage Awning Assembly		1	1
<input type="checkbox"/>	2	Mounting Bracket		4	
<input type="checkbox"/>	3	Hardware Kit (Roof Mount)			8
		Screw, Thread Forming	1/4"-20 x 3/4"	4	
		Screw	3/8"-16 x 1 1/4"	24	
		Flat Washer	3/8"	24	
		Nut, Nylock	3/8"	24	
		Hex Key	7mm x 133mm	1	
<input type="checkbox"/>	4	Hardware Kit (Wall Mount)			8
		Screw, Thread Forming	1/4"-20 x 3/4"	4	
		Screw, Rolock	3/8" x 1 1/2"	24	
		Hex Key	7mm x 133mm	1	
<input type="checkbox"/>	5	Hardware Kit (Through Wall)			8
		Backing Plate		6	
		Backing Plate Cover		6	
<input type="checkbox"/>	6	Control Box	Single Awning	1	2
<input type="checkbox"/>	7	Key Pad Assy	Single Awning	1	2,3
<input type="checkbox"/>	8	Remote Control Key FOB, 433MHz	Single Awning	1	2,4
<input type="checkbox"/>	9	Control Box	Dual Awning	1	2
<input type="checkbox"/>	10	Key Pad	Dual Awning	1	2,3
<input type="checkbox"/>	11	Remote w/ stop, 433 MHz	Dual Awning	1	2,4
<input type="checkbox"/>	12	Control Box 1 (Motor #1, Motor #2)	4-Awning Combo	1	2
<input type="checkbox"/>	13	Control Box 2 (Motor #3, Motor #4)	4-Awning Combo	1	2
<input type="checkbox"/>	14	Key Pad	4-Awning Combo	1	2,3
<input type="checkbox"/>	15	Remote w/ stop, 433 MHz	4-Awning Combo	1	2,4
<input type="checkbox"/>	16	RF Receiver, 433 MHz		1	
<input type="checkbox"/>	17	RJ11 Cable	60"	1	5
<input type="checkbox"/>	18	RJ11 Cable	240"	1	7
<input type="checkbox"/>	19	Sensor, Ignition Lock-Out		1	5,6
<input type="checkbox"/>	20	Splitter		1	5,6
<input type="checkbox"/>	21	Coupler, Cable		1	7
<input type="checkbox"/>	22	Switch and Fuse Kit, LED Lighting		1	9

- Notes:
1. Awning configuration is specified at time of order, including awning length, LH or RH configuration, fabric color etc. Check awning assembly against original purchase order.
 2. Electronic components are not interchangeable between systems.
 3. Mounting screws are included with switches and mounting plates.
 4. Additional remotes can be ordered separately.
 5. 60" cable (item 17) is furnished with items 7, 10 and 14, one additional cable is furnished with the 4-awning control boxes (items 12, 13).
 6. The optional ignition lockout and splitter (items 19, 20) must be ordered separately. Two versions of the lockout sensor are available, refer to page 11 for description.
 7. Long cable (item 18) and /or coupler (item 21) are specified at time of order.
 8. Hardware kits (items 3, 4 & 5) are specified at time of order.
 9. The LED switch and fuse kit (item 22) is optional and ordered separately for the factory installed LED lighting option. LED lighting is optional and specified at time of order.

INSTALLATION – MECHANICAL

 The Mirage awning has significant weight. The awning and attaching brackets must be securely attached to the structural frame of the vehicle. Consult the coach manufacturer to determine the type and position of the structural members and the structure's ability to support the weight. Failure to heed this warning can result in serious injury and property damage.



CAUTION

The awning is extremely heavy. Moving and/or lifting the awning requires a minimum of 3 people. The use of a lifting device is strongly recommended.

REQUIRED PRE-INSTALLATION PARAMETERS

Prior to installing the awning system, the installer must determine the layout of the system and provide specific construction elements to successfully assemble the awning components.

Prior to installing the awning, the installer must determine the layout of the specific construction elements to successfully assemble and mount the awning.

1. Determine the location, size and type of structural framing in the area where the awning is to be mounted.
 - 1.1. There must be structural framing at the awning mount locations. Fiberglass or sheet metal siding alone is **NOT** strong enough to support the weight of the awning!
 - 1.2. If the framing is not obvious, it may be possible to use a stud finder or other similar device to locate the frame.
 - 1.3. If in doubt, contact the coach manufacturer to determine the type and position of the structural frame.
2. Determine the mounting locations for the control box and switch assemblies.
 - 2.1. For 110VAC installations, the installer must provide enclosed junction boxes for all wire splices. Boxes are required in conformance with prevailing construction codes.
 - 2.2. At the control box location, AC input is required. It is recommended that the installer provide a dedicated AC circuit for the awning system that is protected by an appropriate sized fuse/circuit breaker. Each patio awning draws a maximum of 3 amps.
 - 2.3. The motion sensor for the *Direct Response* system is mounted on the lead rail of the patio awning. 10 feet cable is available from the awning mount position, and will require a routing path to the control box. If the control box is located at a distance greater than 10 feet, the installer must provide a terminated jumper cable from the box location to the cable end.

MOUNTING PLATE LAYOUT AND INSTALLATION

Mounting Height

The chart below provides the minimum distance from the top of a projection (i.e. open door or slide out) to the bottom of the mounting plate. This provides clearance for the travel path of the lead rail.

Below is the mounting pattern using four (4) mounting brackets

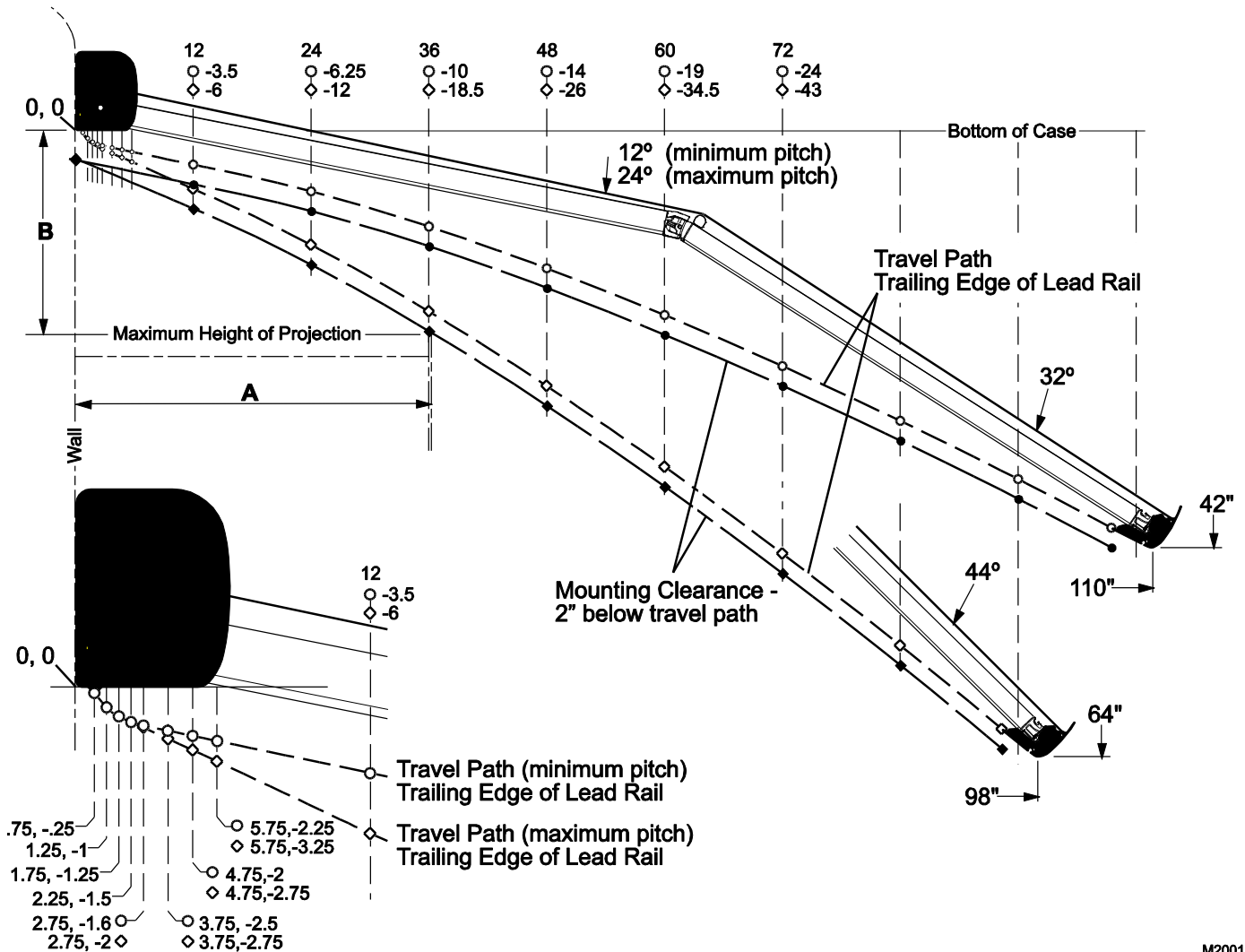

M2001a

A Projection (Door/Slideout) →	0"	12"	24"	36"	48"	60"	72"
● B Min. Mounting Height (min. pitch) ↑	3"	5.5"	8.25"	12"	16"	21"	26"
◆ B Min. Mounting Height (max. pitch) ↑	3"	8"	14"	20.5"	28"	36.5"	45"

The minimum mounting height (B) is measured from the uppermost edge of the projection (i.e. door, slideout room flange) to the bottom of the mounting plate. The value given is a minimum requirement, adjust upward as required to clear casing, trim etc.

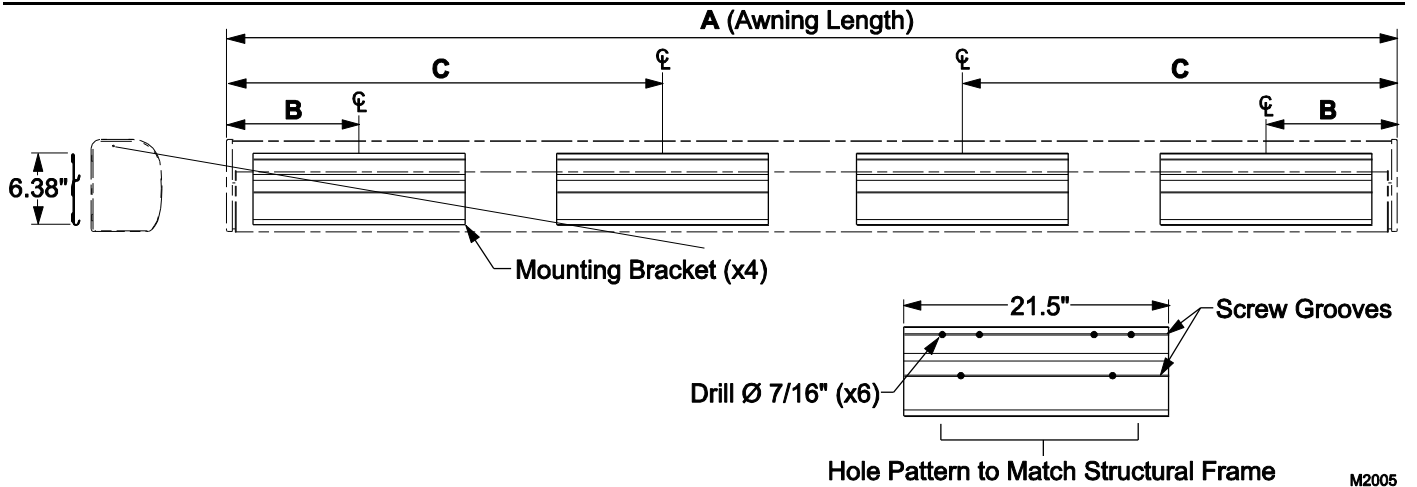

A (feet)	B (inches)	C (inches)	A (feet)	B (inches)	C (inches)	A (feet)	B (inches)	C (inches)
12'	13	51.25	16'	13	67.75	20'	15.5	85.75
13'	13	54.25	17'	13	70.75	21'	15.5	88.75
14'	13	57.25	18'	13	73.75			
15'	13	64.75	19'	13	76.75			

NOTICE If the mounting plates must be located differently than the recommended positions, It is important that for proper support and awning operation, the mounting brackets must be positioned behind the spring arm case connectors.

1. Determine the location of the awning mounts:
 - 1.1 Mounting area must be flat and clear of obstacles,
 - 1.2 The awnings have appreciable weight; the mounting screws MUST fasten into the structure.
 - 1.3 Drill six (6) 7/16" holes in each mounting plate to match the structural locations.
2. Position the mounting plates on the vehicle. Horizontally position the plates using the dimensions in the chart above.

NOTE: Three mounting hardware kits are available.

 - For wall mount applications, use the kit with rolock screws (item 4 on page 2) to attach the mounting plates to the vehicle's structural framework.
 - For roof mount applications using installer furnished supports, use the screws and nuts (item 3 on page 2) to attach mounting plates to supports.
 - For through the wall mounting use the backing plate and cover (item 5 on page 2). Please note that installer must furnish the 3/8" screws, washers and nuts to fit the installation.
3. For rolock thread cutting screws:
 - 3.1 For each plate, on one end of the plate, use the plate as a template and drill an 11/32" pilot hole into the structure. Attach the plate using a 3/8"-16 x 1 1/2" thread cutting screw.
 - 3.2 Confirm position of plate and repeat step 6 on the opposite end of the mounting plate.
 - 3.3 Continue to drill and attach using the 3/8"-16 x 1 1/2" thread cutting screws. Use six (6) screws minimum per plate.
4. For installer furnished roof mount supports :
 - 4.1 Align each plate with the supports, use the plate as a template and drill a 7/16" pilot hole into the structure. Attach the plate using a 3/8" x 1 1/4" screw, washer and nylock nut.
 - 4.2 Confirm position of plate and repeat step 6 on the opposite end of the mounting plate.
 - 4.3 Continue to drill and attach using the 3/8" screws, washers and nuts. Use six (6) screws per plate.
5. At the motor location, drill one (1) 1/2" hole through outer surface. The position should be behind the motor end cap position.

Alternate Mounting Plate Attachment Method

NOTICE This method should be used only as required. Primary attachment **MUST** be into the structure as described above.

When it is not possible to attach into structure or if the screws will be exposed inside the coach, an alternate method is to use a backing plate and cover. The installer must furnish the 3/8 bolts, washers and lock nuts.

1. Using the mounting plate as a template, drill 7/16" holes through the wall. The inside of the wall must be accessible.
2. Attach as shown using a backing plate and cover. Torque nuts to 50 in-lb.

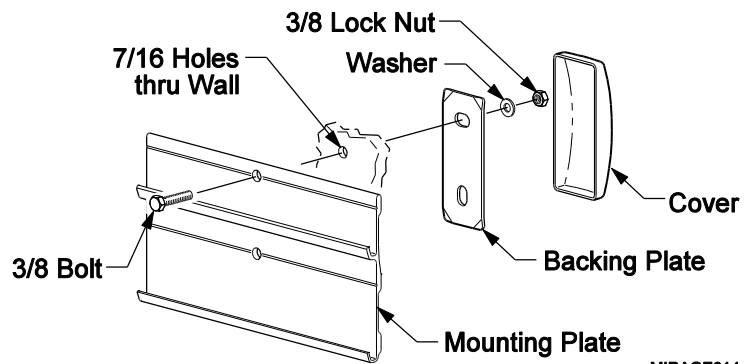

MIRAGE014

MOUNTING THE AWNING UNIT

1. While lifting the awning, route the awning motor wires through the 1/2" hole drilled previously.

NOTE: It is necessary to first insert the sensor cable and connector through the hole then insert the motor wires.

2. Set the awning into the hooks of the mounting plate.
3. Adjust the horizontal position of the awning as required.

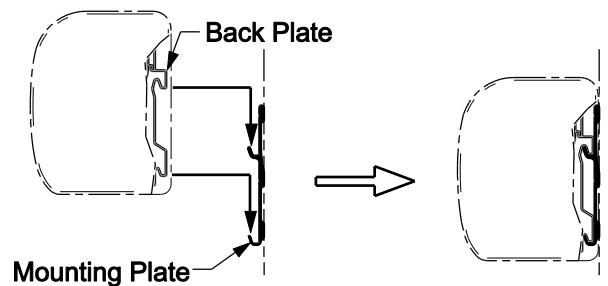

M2006

SECURING THE AWNING

NOTE: This procedure requires opening the awning. Follow the Manual Override instructions on page 20. These steps can be done after the electrical installation when motorized power is available.

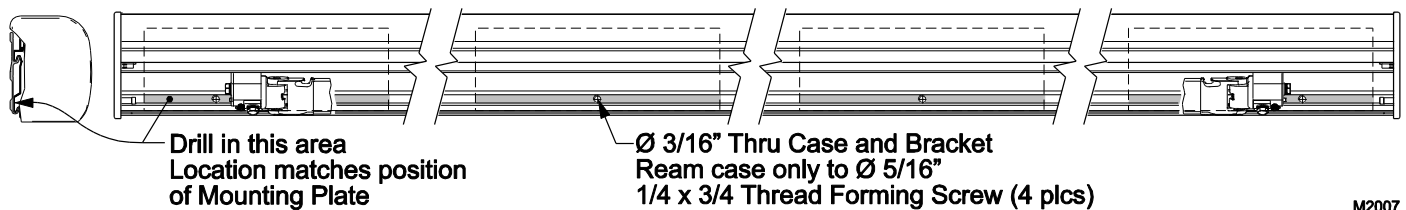

M2007

1. Adjust the awning horizontally as required.
2. Open the awning approximately 3 feet to access the back panel of the awning case.
3. Drill four (4) 3/16" holes through the case, mounting plates and into wall (do not go through interior surfaces of wall) in the gray areas shown above. The recommended areas match the positions of the mounting plates.
4. Ream out the holes in the case only to 5/16".
5. Attach the awning case to the mounting plate and wall using four (4) 1/4" x 3/4" thread forming screws.
6. From inside, seal the wires and access hole with a quality silicone sealant.

ELECTRICAL INSTALLATION



WARNING Shock Hazard. Always disconnect battery or power source before working on or around the electrical system.

IMPORTANT NOTICES:

- Failure to follow the wiring instructions in this publication may void the warranty.
- All wiring must conform to NEC (National Electrical Code) and local codes.
- DO NOT wire two or more motors to one motor controller.
- The SO cable from the 110VAC awning motor can only pass directly through a wall, it can not be laid up in the wall and must be connected to NM wire or individual wires in conduit no more than 6 inches past the point of entry.
- The installer must provide enclosed junction boxes for all 110VAC wire splices. Boxes are required in conformance with prevailing construction codes. Installers are required to furnish the UL approved electrical boxes where required.
- At the control box location, AC input is required. It is recommended that the installer provide a dedicated AC circuit for the awning system that is protected by an appropriate sized fuse/circuit breaker. Each patio awning draws a maximum of 3 amps.
- The motion sensor for the *Direct Response* system is mounted on the patio awning. 10 feet cable is available from the awning wall mount, and will require a routing path to the control box. If the control box is located at a distance greater than 10 feet, the installer must provide a terminated jumper cable from the box location to the cable end.
- Terminated cable is a 4-wire RJ11 terminated phone cord (straight, no twist).

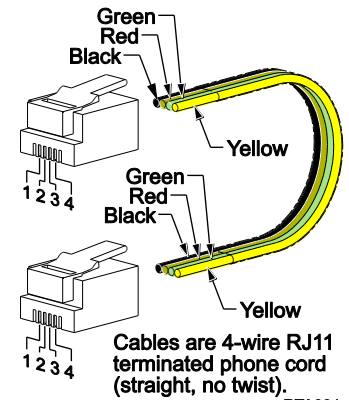

NOTE: Cable lengths of the furnished cables are listed in the chart with the system wiring diagram. If a connection requires a length greater than the supplied cable, the installer must provide a terminated jumper cable from the box location to the cable end. Terminated cables are 4-wire RJ11 terminated phone cord (straight, no twist).

KEY PAD INSTALLATION

1. Locate the mounting location of the key pad. The key pad requires a flat area approximately 2 3/4" wide by 4 1/2" tall.
2. Use the mounting plate as a template and mark the location of the two mounting holes.
3. Remove the plate, mark and cut a 1" hole in the position shown.
4. Mount the plate to the surface using the included screws.
5. Route the 25 foot RJ11 cable from the control box location through the wall and mounting plate.
6. Attach the cable to the back of the key pad then attach the key pad to the mounting plate.

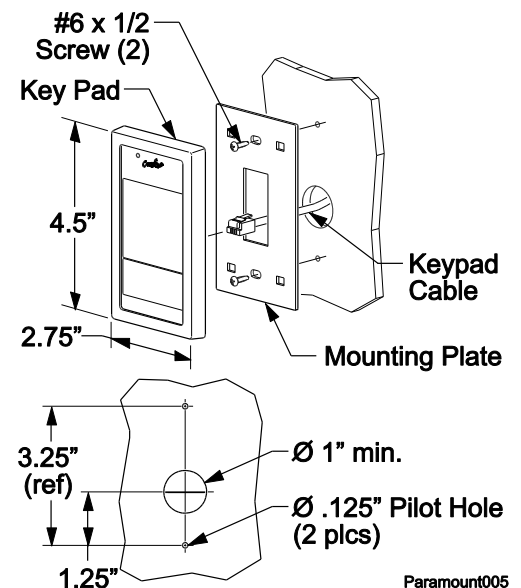

NOTE: The key pad attaches to the plate with magnetic latches. No additional attaching hardware is required.

CONTROL BOX INSTALLATION

NOTES:

- For Multiple Awning Installations:** The awning motor that is connected to the controller board marked "motor #1" will correspond with "Awning 1" on the touch pad control and remote. The awning motor connected to "motor #2" will correspond with "Awning 2" on the controls etc.
- For 4-Awning Installations:** Awnings connected to motor #1 & #2 correspond to "Passenger Side Awnings", awnings connected to motor #3 & #4 correspond to "Driver Side Awnings".
- The control boxes are not suitable for exterior installations and must be mounted in the INTERIOR of the vehicle.

For Single Awning installations: refer to wiring diagram on page 12.

For 2-Awning installations: refer to wiring diagram on page 13.

For 4-Awning installations: refer to wiring diagram on page 15.

- Locate the mounting location of the control box(es). Each box requires a flat area approximately 6 1/2" x 6 1/2" with a clearance depth of 2 3/8".

For 4 awning installations: A 60" jumper cable is used between the two control boxes. This allows approximately 55" of cable between the boxes. Position the boxes to allow the jumper to be connected and routed with some slack in the cable.

- Remove the lid. Attach the box to the mounting surface using a minimum of two (2) #8 x 3/4 screws each. The screws must be mounted in opposite corners.
- Route a 2-conductor 14AWG NM wire w/ ground from the AC power source to the box. It is recommended that the installer provide a dedicated AC circuit that is protected by an appropriate sized fuse/circuit breaker. Each patio awning draws a maximum of 3 amps.

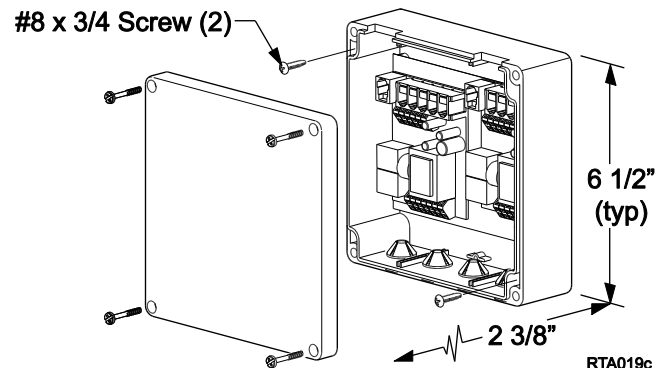

NOTE: Each board must have a 110VAC supply. The diagram shows a separate power source for each box; each power source is spliced with wire nuts to power both boards in a box.

- Connect the wires to the control box circuit boards as shown in the wiring diagram (Detail A).
- Route the motor wires from awning #1 to controller #1 (motor#1); attach the wires to the terminals as shown.

NOTE: For RH motor configurations:

RED WIRE goes to terminal (1);

BLACK WIRE goes to terminal (2).

For LH motor configurations:

RED WIRE goes to terminal (2):

BLACK WIRE goes to terminal (1).

- Attach the RJ11 cable from the sensor of awning #1 to the "AMD" receptacle of controller #1.
- Repeat step 5 and 6 for the other awnings.
- After testing connections, use Loctite 29005 or equivalent to secure screws in terminal block.
- Attach the remaining RJ11 cables as shown in the wiring diagram. Use the slot cutouts in the box to route the phone cables.

NOTE: The key pad and RF receiver only attach to controller #1.

INSTALLING THE REMOTE RECEIVER

1. Determine the location of the RF receiver:
 - 1.1 Do not mount the unit near heat producing elements such as LP appliances or engine exhaust components.
 - 1.2 For best reception, do not mount the unit near or on a metal surface.
 - 1.3 Mount the unit with the antenna pointing up.
 - 1.4 The included cable is approximately 60 inches long. Mount the unit close enough to the splitter or control box so that the cord can be connected without stressing the connections.
 - 1.5 Allow adequate room below the box to access the connector jack, programming button and indicator light.
2. Position the control box and secure using two (2) #6 x 1/2" screws.

NOTE: If the box is mounted on a surface that is less than 1/2" thick, the screws will protrude through the opposite side of the surface.
3. Connect the cable to the receiver.
4. Route the cable to the splitter; or, to the control box and connect to "EYE".

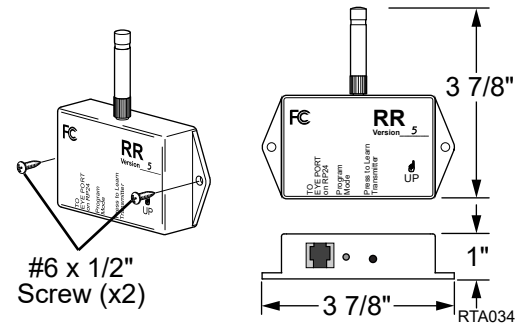

PROGRAMMING THE REMOTE RECEIVER

1. Power to the control box must be on.
2. Press and release the "Press to Learn Transmitter" button on the bottom of the receiver box. The receiver is in program mode when the red light comes on.
3. Press and release the stop button on the remote. The red light will go out after the receiver learns the remote signal.

NOTE: For single awning key FOB remotes: Pressing the stop button will cause the blue up arrow button to default as the open (extend) function. If a function button is pressed to train the receiver, it will be programmed as the open (extend) button. Example: Pressing the bottom button will program the bottom button for extend and the top button as retract.

4. Repeat for each additional remote.

OPERATIONAL NOTES:

- Transmitter and receiver operate on a frequency of 433 MHz.
- The receiver exits the program mode after ten seconds.
- If the light does not come on above, the memory is full and must be cleared. If the light still does not come on, check the continuity of the cord between the boxes and repair or replace as required. Pin 1 of the 1st connector goes to pin 1 of the 2nd connector etc.
- If the light does not go out in above, the receiver already knows the transmitter's signal or the battery in the remote needs to be replaced.
- To clear the memory: PRESS AND HOLD the transmitter learn button. While holding the button, the indicator light should be OFF for the full 5 seconds then come on.
- The system may be programmed for up to 5 remotes. Additional remotes may be ordered separately.

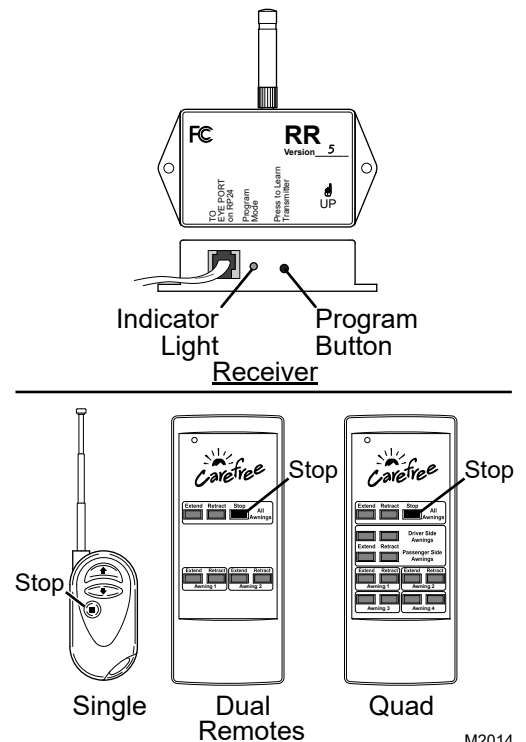

M2014

IGNITION LOCKOUT SENSOR INSTALLATION (OPTIONAL)

Two ignition lockout sensors are available with the Direct Response System.

- The STD ignition lockout module disables the extend function when the module receives a current through a switched 12VDC circuit.
- The RTL ignition lockout module will fully retract the awning and disable the extend function when the module receives a current through a switched 12VDC circuit.

A switched 12VDC source is a line that is "hot" when the ignition switch is in the on position; or, a 12VDC circuit through a relay that is "hot" when a specific condition is met (i.e. releasing the parking brake). Relays are not furnished.

1. Disconnect power to the awning. Shut off the power source or pull the appropriate circuit breaker.
 2. Locate the control box for the Direct Response System.
 3. Open the cover of the control box.
 4. For Single Awning Applications:
 - 4.1. Disconnect the remote receiver cable from the "EYE" port in the control box. Do not disconnect the cable from the receiver box.
 - 4.2. Connect the supplied 6" cable to "EYE" port in the control box.
 - 4.3. Attach the splitter to the other end of the cable.
 - 4.4. Plug the cable from the remote receiver into the splitter.
 - 4.5. Attach the Lock-Out Sensor to the end of the 60" cable. Route the cable as desired and connect the cable to the splitter.
 - 4.6. Proceed to step 6.
 5. For Multiple Awning Applications:
 - 5.1. The module may be connected to the control box as described for single awning applications.
OR
 - 5.2. The module may be directly connected to any open "EYE" port on any of the control boards. It is not necessary to use the short cable or splitter.
 - 5.3. Proceed to step 6.
- NOTE:** Wires to the module are not pin specific.
6. Attach one 18-gauge wire to a terminal of the sensor and route the wire to a suitable 12VDC ground.
 7. Attach a second 18-gauge wire to the second terminal of the sensor and route the wire to a SWITCHED 12VDC source.
 8. Bundle and secure the sensor, cable and wires as required.
 9. Reattach the control box cover.

WIRING DIAGRAM – SINGLE AWNING

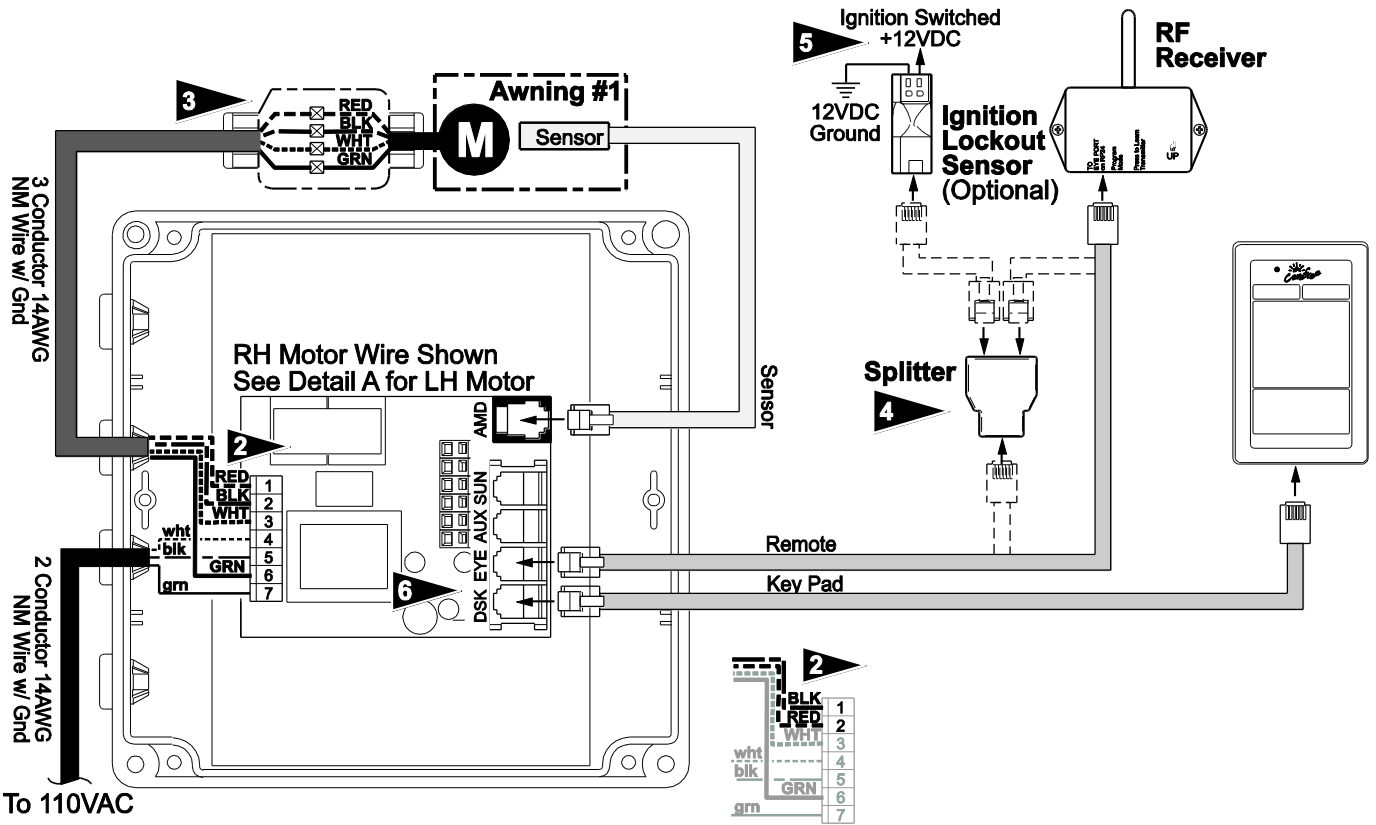

NOTES:

- 1** Wire Legend:
 - Red
 - Black
 - White
 - Green (Ground)
- 2** For RH Motor Configurations: Motor Red goes to Pin (1); Motor Black goes to Pin (2)
 For LH Motor Configurations: Motor Red goes to Pin (2) Black; Motor Black goes to pin (1)
- 3** The SO cable from the 110VAC awning motor can only pass through a wall, it cannot be laid up in the wall and must be connected to NM wire or individual wires in conduit no more than 6 inches past the point of entry.
- 4** Splitter is used only when Optional Lock-Out Sensor is installed. Connect RF Receiver directly to "EYE" if Lock-Out is not installed.
- 5** Wires for the Ignition Lock-Out Sensor are not pin specific.

Detail A
 For LH Configuration
 Reverse Red & Black Wires

DR012a

	FROM		TO (RH CONFIGURATION)		TO (LH CONFIGURATION)	
	Wire Color	Terminal	Wire Color	Terminal	Wire Color	Terminal
Motor	Black	Control Box	1	Control Box	2	
	Red	Control Box	2	Control Box	1	
	White	Control Box	3	Control Box	3	
	Ground	Control Box	6	Control Box	6	
AC Power Source	White	Control Box	4	Control Box	4	
	Black	Control Box	5	Control Box	5	
	Ground	Control Box	7	Control Box	7	
Awning Sensor	10' Cable	Control Box	"AMD"	Control Box	"AMD"	
Key Pad	60" Cable	Control Box	"DSK"	Control Box	"DSK"	
Splitter	60" Cable	Control Box	"EYE"	Control Box	"EYE"	
RF Receiver	60" Cable	Splitter		Splitter		
Ignition Lockout	60" Cable	Splitter		Splitter		

Notes: 1. Cable lengths are the lengths of the furnished cables. If a connection requires a length greater than the supplied cable, the installer must provide a terminated jumper cable from the box location to the cable end.

WIRING DIAGRAM – 2-AWNINGS

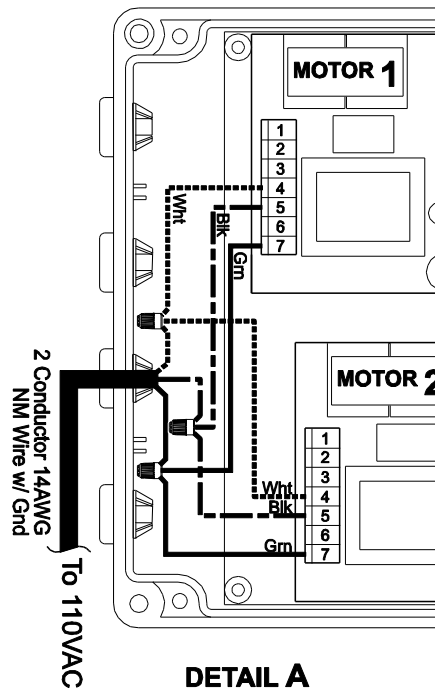
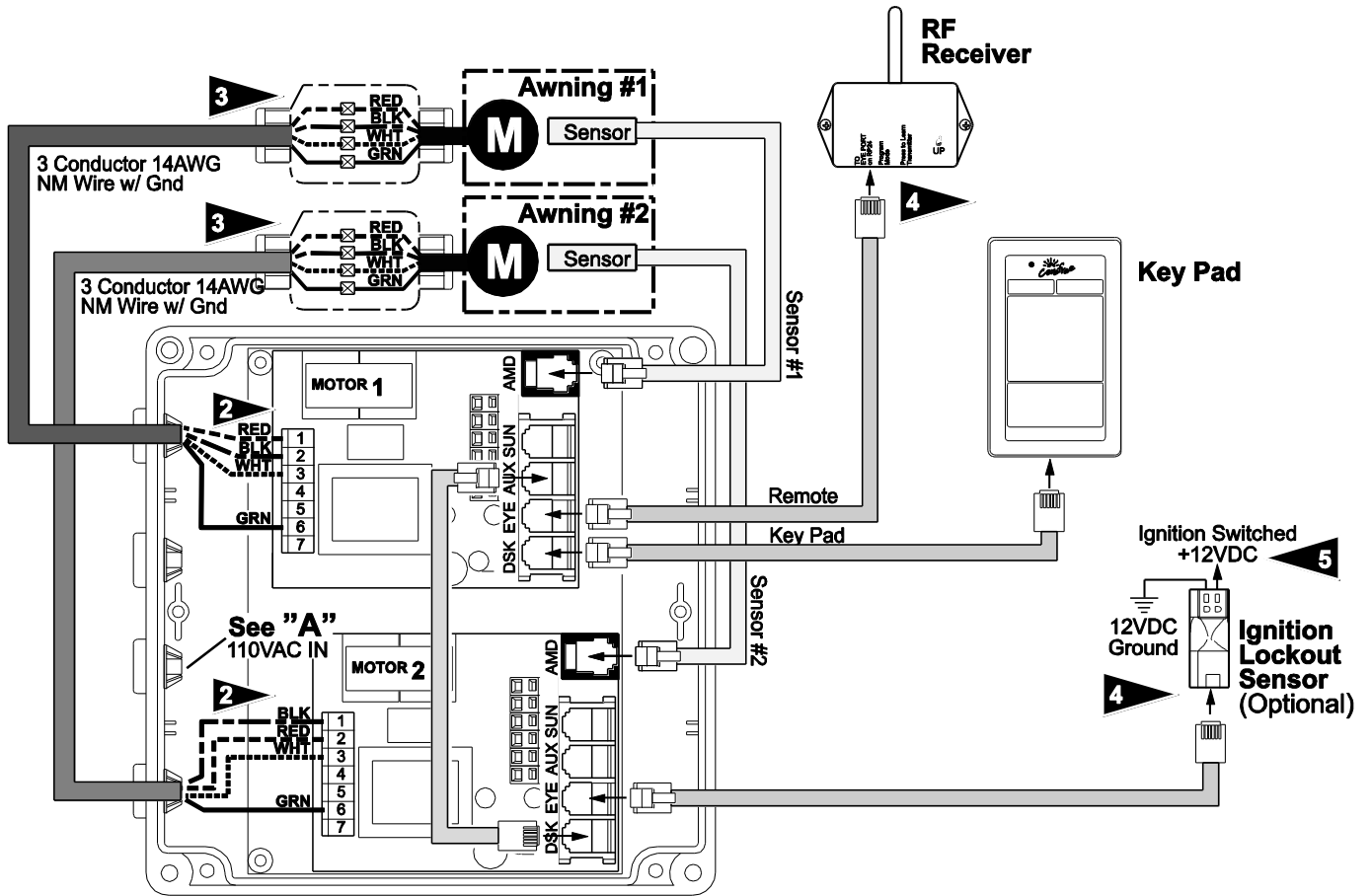

DR014a

NOTES:

- 1 Wire Legend
- Red
 - Black
 - White
 - _____ Green (Ground)

- 2 Awning #1 shown as RH Motor, Awning #2 shown as LH Motor
- For RH Motor Configurations:**
 Motor Red goes to Pin (1); Motor Black goes to Pin (2)
- For LH Motor Configurations:**
 Motor Red goes to Pin (2); Motor Black goes to Pin (1)

- 3 The SO cable from the 110VAC awning motor can only pass directly through a wall; it cannot be laid up in the wall and must be connected to NM wire or individual wires in conduit no more than 6" past the point of entry.

- 4 The RF Receiver and the optional Ignition Lockout may be plugged into any open "EYE" port.

- 5 Wires for Ignition Lock-Out Sensor are not pin specific.

- 6 For screw type terminals: After testing connections, use Loctite 29005 or equivalent to secure screws in terminal block

- 7 Cables are 4-wire RJ11 terminated phone cord (straight, no twist).

- 8 Terminal block designations are for reference only. Actual boards may not be marked.

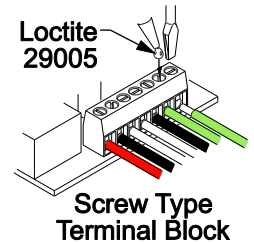

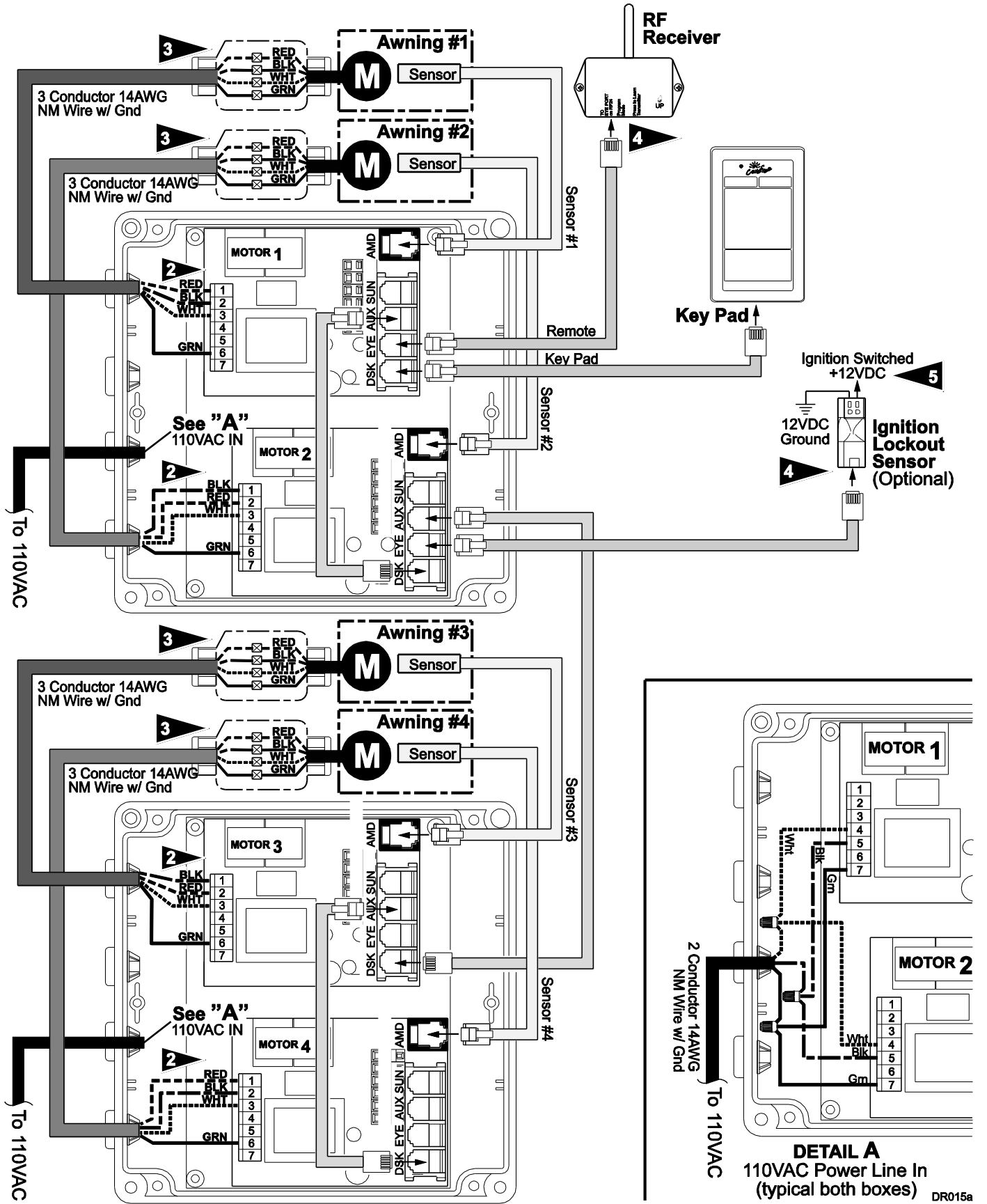

FROM		TO CONTROL BOARD		
		MOTOR #1	MOTOR #2	
AC Power Source	White	4	4	
	Black	5	5	
	Ground	7	7	
Awning #1 Motor	Black	Refer to Flag Note 2		
	Red			
	White			3
	Ground			6
Awning #2 Motor	Black		Refer to Flag Note 2	
	Red			
	White			3
	Ground			6
#1 Sensor	10' Cable	"AMD"		
#2 Sensor	10' Cable		"AMD"	
Key Pad	25' Cable	"DSK"		
RF Receiver	60" Cable	"EYE" see note 4		
Ignition Lockout	60" Cable	"EYE" see note 4		

WIRING DIAGRAM – 4 AWNINGS





NOTES:

- 1  Wire Legend
 - Red
 - Black
 - White
 - _____ Green (Ground)

- 2  Awnings #1 & #4 shown as RH Motor, Awnings #2 & #3 shown as LH Motor
 - For RH Motor Configurations:**
Motor Red goes to Pin (1); Motor Black goes to Pin (2)
 - For LH Motor Configurations:**
Motor Red goes to Pin (2); Motor Black goes to Pin (1)

- 3  The SO cable from the 110VAC awning motor can only pass directly through a wall; it cannot be laid up in the wall and must be connected to NM wire or individual wires in conduit no more than 6" past the point of entry.

- 4  The RF Receiver and the optional Ignition Lockout may be plugged into any open "EYE" port.

- 5  Wires for Ignition Lock-Out Sensor are not pin specific.

- 6  For screw type terminals: After testing connections, use Loctite 29005 or equivalent to secure screws in terminal block

- 7  Cables are 4-wire RJ11 terminated phone cord (straight, no twist).

- 8  Terminal block designations are for reference only. Actual boards may not be marked.

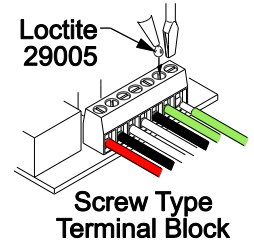

FROM		TO CONTROL BOARD				
		MOTOR #1	MOTOR #2	MOTOR #3	MOTOR #4	
AC Power Source	White	4	4	4	4	
	Black	5	5	5	5	
	Ground	7	7	7	7	
Awning #1 Motor	Black	Refer to Flag Note 2				
	Red					
	White					3
	Ground					6
Awning #2 Motor	Black		Refer to Flag Note 2			
	Red					
	White					3
	Ground					6
Awning #3 Motor	Black			Refer to Flag Note 2		
	Red					
	White					3
	Ground					6
Awning #4 Motor	Black				Refer to Flag Note 2	
	Red					
	White					3
	Ground					6
#1 Sensor	10' Cable	"AMD"				
#2 Sensor	10' Cable		"AMD"			
#3 Sensor	10' Cable			"AMD"		
#4 Sensor	10' Cable				"AMD"	
Key Pad	25' Cable	"DSK"				
RF Receiver	60" Cable	"EYE" see note 4				
Ignition Lockout	60" Cable	"EYE" see note 4				

CONNECTION FLEX W/ "110VDR" CONTROL BOXES

The wiring diagrams show the standard installation for multiple awning configurations. For control boxes marked w/ "110VDR", the installer may adjust the cable interconnections for greater flexibility during installation.

1. The key pad may be installed in the unused DSK port of any board with the jumper cables sequentially connected from the AUX port to the DSK port of the next board.

Example: Placing the keypad in the DSK of Board 3.

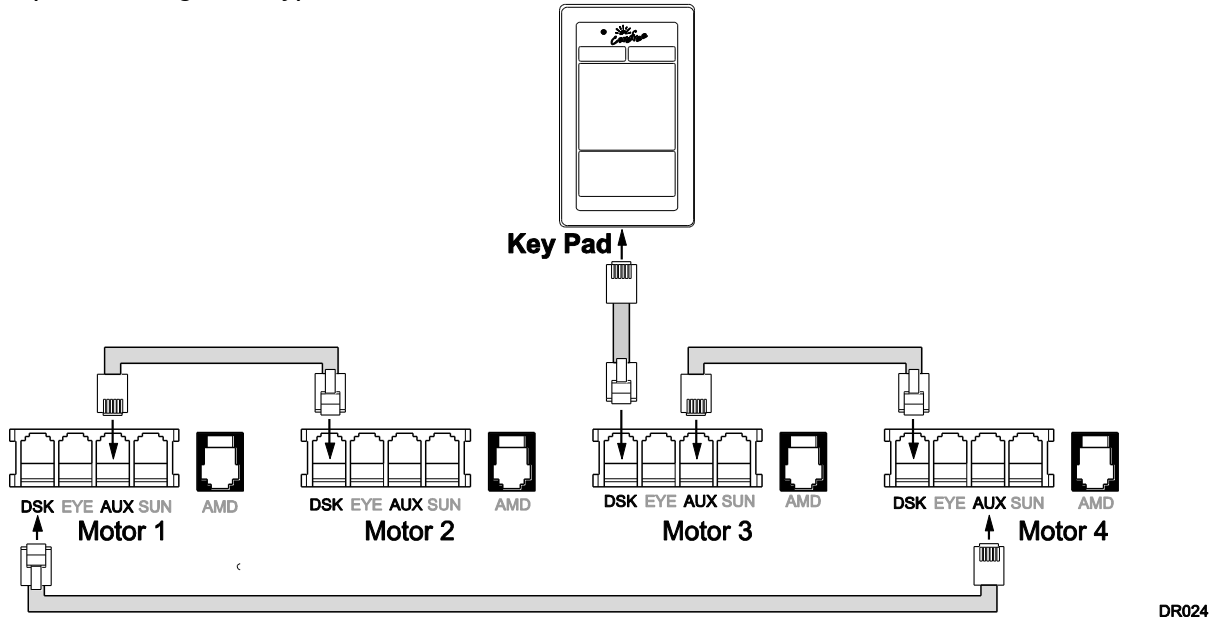

2. The RF Receiver and the optional ignition lock-out can be plugged into any unused "EYE" port. It is not necessary to use the splitter as shown in the diagrams.
3. The "110VDR" control boxes are compatible with integrator interfaces. Contact Carefree engineering for information and system requirements.

OPTIONAL MANUAL BYPASS SWITCH

Installers may elect to install a manual bypass switch for testing or emergency operation of the awning. The simple switch allows the operator to extend or retract the awning without using the keypad control panel. For multiple awning installations, a separate switch must be installed for each awning.

1. Open the control box and identify the terminal block next to the phone cord jacks.
2. Connect the switch to the terminal block as shown in the diagram.

The switch is a single pole, double throw, momentary ON, center OFF. Components are installer furnished.

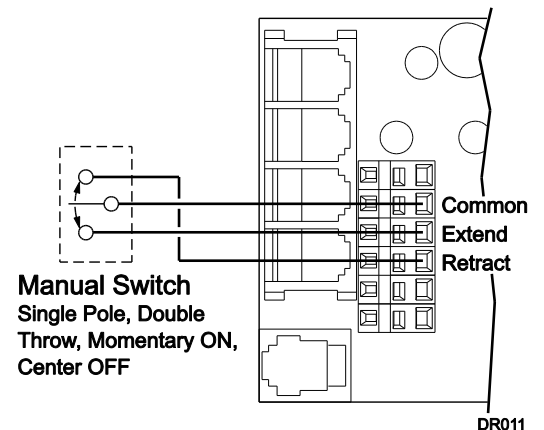

OPTIONAL LED LIGHTING SWITCH INSTALLATION

An optional factory installed LED light strip is available for the Mirage 2-Stage awning. The strip is mounted in the lead rail; the harness is routed through the awning with the Direct Response cable.

For multiple awning installations, each LED strip may be attached to an individual switch or two LED strips can be hooked in parallel to a single switch.

NOTE: Installers may choose to furnish the control switch. The installation requires that the power line (+12VDC) be attached to a dedicated 2A circuit breaker or a 2A in-line fuse must be installed between the switch and power source. For easy access, locate the fuse close to the switch.

1. Route the harness into the vehicle with the Direct Response cable and the motor power cable.
2. Determine the location of the switch.
3. At the switch location, cut a 1 1/8" x 1 1/2" hole.

4. Wire the switch as shown below. Wire terminals at the switch are .187, 18-24 awg female disconnects.

NOTE: Allow adequate slack in the 12VDC power line so that the in-line fuse (installed in step 4) can be accessed from behind the switch.

5. Install the in-line fuse:
 - 5.1. Near the switch, cut the red 12VDC power line to the switch. Do not strip the insulation.
 - 5.2. Insert a wire end into one of the wire channels until it butts up against the stop.
 - 5.3. Fold that half of the connector body over until the element contacts the wire. Use pliers to crimp the connector closed.
 - 5.4. Repeat for the second wire end.
 - 5.5. Slide the fuse into the fuse port. Ensure that is firmly seated.

6. Press the in-line fuse, wires and switch into the mounting hole. Secure the switch using two (2) #6 x 1/2" screws.
7. Snap the switch bezel over the switch frame.
8. Kit SR0101 is available from Carefree and includes switch, fuse holder and 2A fuse.

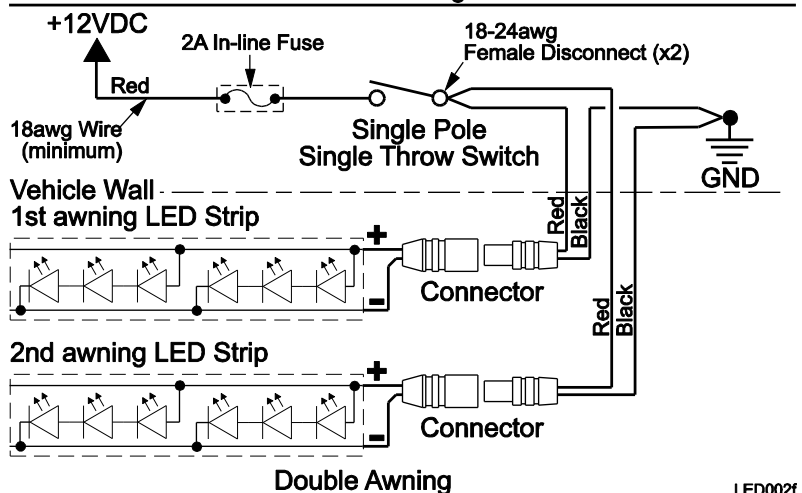
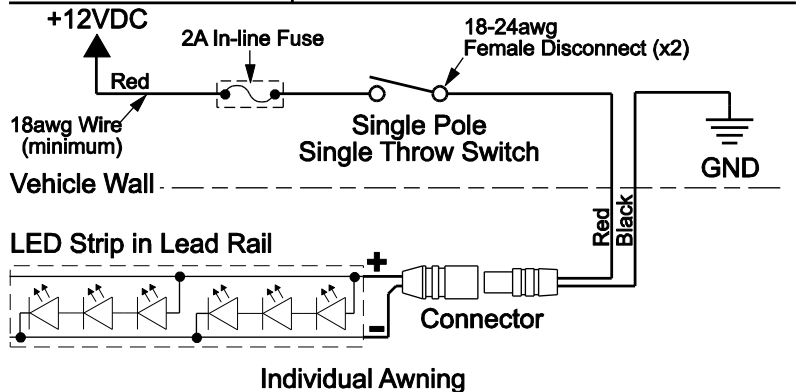
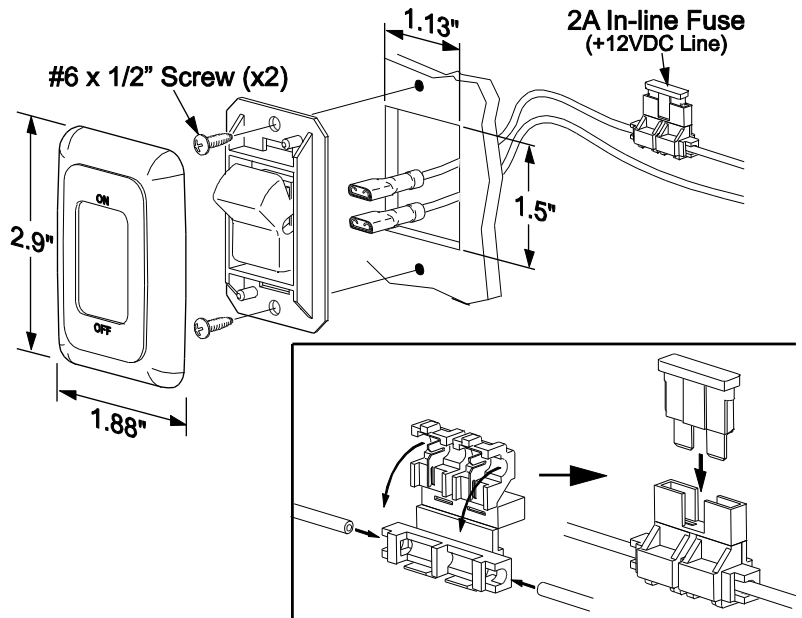

LED002f

TESTING THE SYSTEM

All function buttons are press ON. The auto-functions continue until the awning is fully extended or retracted. Pressing the button a second time will stop the function (does not apply to the "Extend All" or Retract All" commands). It is not necessary to hold the button while the function is active.

1. While observing the control panel, have a second person initiate 110VAC power to the coach and awning system. The following should occur:
 - 1.1 The System Indicator and Sensitivity Level LEDs will briefly illuminate.
 - 1.2 The system then goes to the default settings: The default settings are the last known state when the AC power source was suspended. Example: If power was "ON" and the sensitivity was set to "2", when AC power is applied, power will be on and sensitivity will be set to "2".
2. If ON press the POWER "OFF". ALL LEDs should be extinguished. The POWER ON/OFF button disables all functions including Auto-Retract and the RF remote. It does not disconnect the 110VAC power.
3. Check the extend function.
 - 3.1 Press the POWER "ON".
 - 3.2 Press the Awning #1 EXTEND button. The awning should extend.
 - 3.3 Press the extend button again. The awning should stop
 - 3.4 Press the extend button a third time. Observe the awning, it should fully extend. The system performs an auto-tension action when the awning is fully extended. The awning rolls in reverse to tension the fabric. The auto-tension feature works only with the extend function when the awning is fully extended.
4. Check the retract function.
 - 4.1 Press the Awning #1 RETRACT button. The awning should retract.
 - 4.2 Press the retract button again. The awning should stop
 - 4.3 Press the retract button a third time. Observe the awning; it should fully retract to the closed position.

NOTE: If the awning moves in the opposite direction than the label, the red and black MOTOR wires are reversed in the control box.
5. Repeat steps 3 and 4 for each of the Extend/Retract button combinations.
6. Test the Auto-Retract function:
 - 8.1 Fully extend awning #1.
 - 8.2 Set the WIND SPEED to the lowest setting.
 - 8.3 Create a firm but gentle vertical rocking motion with the leading edge of the awning. The awning should retract after 2-3 seconds of the motion. The awning will retract to the slide-out position.
7. Repeat step 6 for each of the awnings.
8. *If the optional Ignition Sensor is installed:*
 - 10.1 Partially retract the awning.
 - 10.2 Turn the vehicle ignition key ON.
 - 10.3 If the RTL lockout is installed, the awning(s) will retract.
 - 10.4 Press the EXTEND button. The awning(s) should not extend.

STANDARD SYSTEM ADJUSTMENTS

ADJUSTING THE PITCH

NOTICE During installation or when the pitch of the awning is adjusted, it is important that the leadrail is parallel to the awning housing.

1. Extend the awning fully.

To Lower the Pitch:

2. SLIGHTLY loosen the M12 hex screw on the side of the knuckle.
3. On the front of arm knuckle turn the M12 hex screw COUNTERCLOCKWISE to lower the pitch.
4. Tighten the M12 setscrew until snug.

To Raise the Pitch:

5. SLIGHTLY loosen the M12 hex screw on the side of the knuckle.
6. Loosen the M12 set screw several rotations.
7. On the front of arm knuckle turn the M12 hex screw CLOCKWISE to raise the pitch.

NOTE: When raising the pitch, it is helpful to have a second person lift up on the lead rail.

8. Tighten the M12 set screw until snug.
9. Repeat steps 5 through 8 for the other end.
10. When the pitch adjustments are completed, tighten the M12 screws on the side of the knuckle.

When the pitch is adjusted, it is necessary to adjust the angle of the lead rail for the awning to close correctly.

11. SLIGHTLY loosen the M12 nut on the side of each arm knuckle on the lead rail.
12. Turn the M12 setscrews of each knuckle to increase or decrease the angle of the lead rail. The bottom of the lead rail should be parallel with the ground.
13. When the lead rail adjustments are completed, tighten the nut on the side of the knuckles.

MANUAL OVERRIDE

If 110V power is not available to the vehicle, the awning can still be safely retracted using the manual override. The bypass may be accessed from inside the case on the motor housing or from the top of the case above the motor housing.

To use the inside bottom access: The awning must be open a minimum of 8" to afford access to the override.

To use the top bypass access: Remove the screw and well nut that is used to secure the end cap.

1. Chuck the 7mm hex key into a 3/8" battery powered drill.
2. Insert the hex key into the manual override on the awning. For the top access, it will be necessary to locate the hex by feel; it is not visible with the key inserted in the hole.
3. Operate the drill in the forward (clockwise) direction to close the awning. Reverse the drill to open the awning.

NOTE: When using the bottom override, the awning can only be closed within 6-8". It will be necessary to use the top access to close the awning completely.

4. When done, return the screw and well nut to the top of the case if removed.

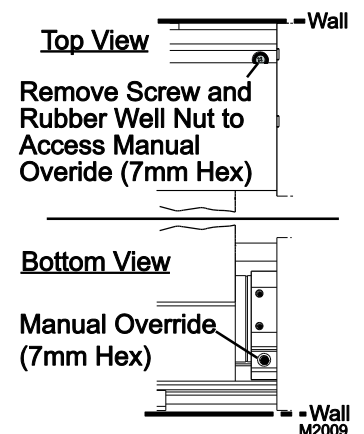
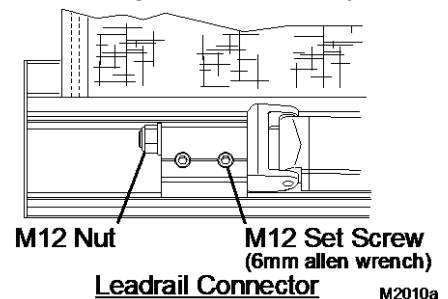
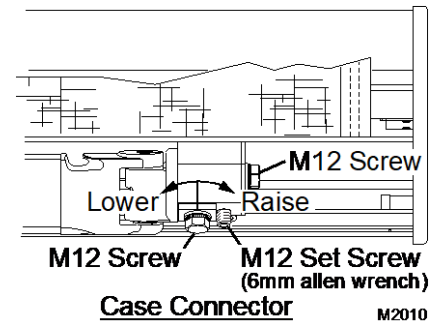

SETTING THE MOTOR LIMITS

The motor limit switches are preset at the factory for best operation. The "OUT" limit switch is used to stop the motor when the awning is fully extended. The "IN" limit is NOT USED with the *Direct Response* system.

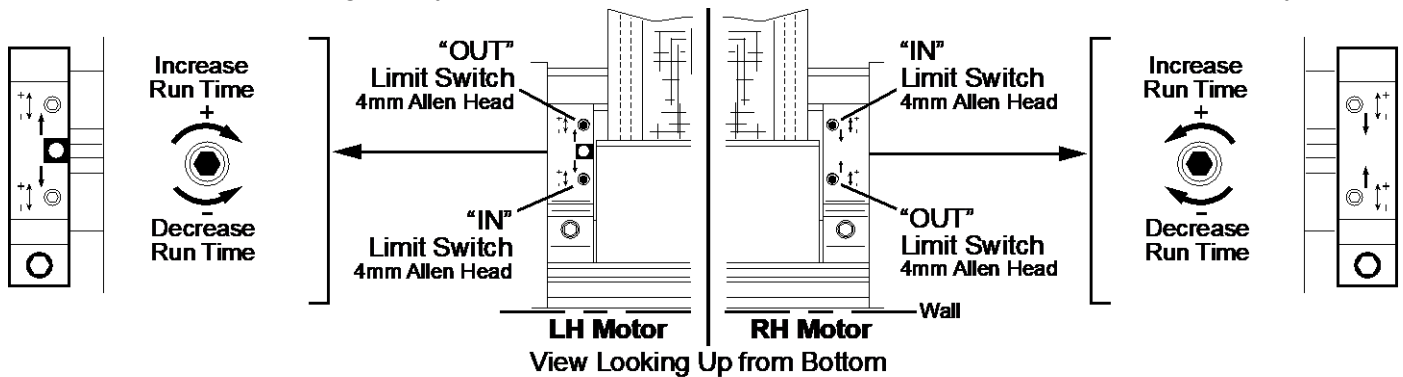

The limit switches are located inside the case, near the end cap. To access the switches, extend the awning 6-8".

MIRAGE023a

Adjusting the OUT Limit Switch

NOTE: During normal operation, the awning will extend out then roll back slightly to tension the fabric.

1. Extend the awning out completely.
2. Confirm that the arms are fully extended. The motor should stop and the fabric should be tight. If the motor continues to run, the fabric will sag; or, if the motor quits before the arms are fully extended, it will be necessary to adjust the "OUT" limit switch.

NOTE: It is best to make the adjustments in increments of a single turn. 3 full turns of the screw equals approximately 2" of fabric extension.

3. If the fabric sags:
 - 3.1. Retract the awning until the fabric is tight then retract an addition 10"-12".
 - 3.2. Using a 4mm Allen wrench turn the "OUT" limit switch COUNTERCLOCKWISE to reduce the time the motor runs.
 - 3.3. Extend to confirm that the adjustment is correct.
 - 3.4. Repeat the procedure until the awning extends correctly.
4. If the arms do not extend completely:
 - 4.1. Retract the awning approximately 10"-12".
 - 4.2. Using a 4mm Allen wrench turn the "OUT" limit switch CLOCKWISE to increase the time the motor runs.
 - 4.3. Extend to confirm that the adjustment is correct.
 - 4.4. Repeat the procedure until the awning extends correctly.

Adjusting the IN Limit Switch

NOTE: The "IN" limit switch is not adjusted with the Direct Response system. The system electronics monitors the motor and shuts the motor off when the awning is fully retracted.

If the IN limit switch is accidentally adjusted, the motor may shut off before the awning is fully closed. If this occurs, turn the "IN" adjustment screw to INCREASE the motor run time. It is not necessary that the screw matches the closed position.

NOTE: It is normal for the lead rail to slightly relax after the awning closes completely.

OEM Representative (please print)

OEM Signature

OEM Position

Date

Carefree Representative (please print)

Carefree Signature/Date

Disclaimer: Carefree performs audits as a service for our customers to help identify situations where installations may not conform to installation instructions, and to identify any potential installation errors. Audits are a random, one-time checkin time and do not verify all the attributes specified in the installation instructions. Carefree cannot be held responsible for any damage or costs as a result of incorrect installation. OEMs must always install products according to installation instructions. This document does not constitute liability or culpability on Carefree’s part for incorrect installations performed by the OEM, dealer, service provider or the consumer.