



# FREEDOM RM ADAPTOR BRACKETS

Kit No: BS0002

**Kits**

4M AND SMALLER SPRINTER BRACKET

**PACKAGE CONTENTS:**

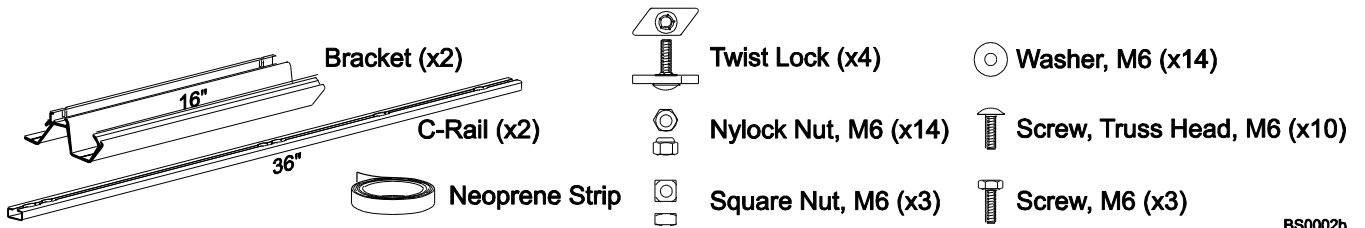

BS0002b

**ATTACHING THE CAREFREE C RAILS**

When the Sprinter van is not equipped with the OEM Sprinter mounting rails, two (2) c-rails are included in the mounting bracket kit. The rails are pre-drilled to match stud locations for the OEM rail.

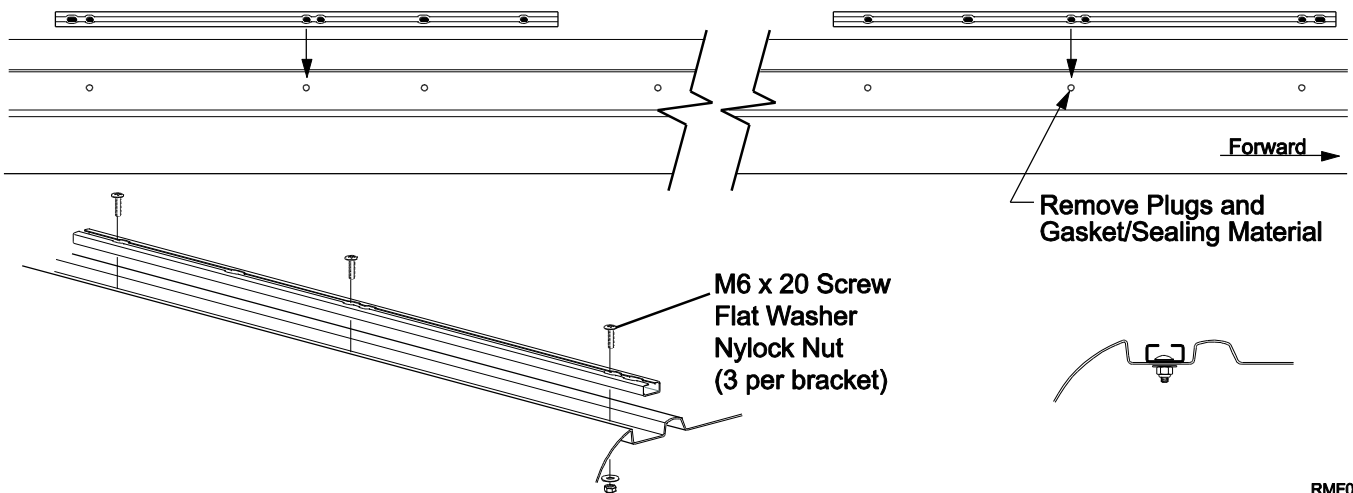

RMF022

1. Set the rails on the van to determine the correct mounting holes to be used. Each rail must be attached with 3 screws. It may be necessary to turn the rail mounted at the rear of the vehicle 180° to match the existing mounting locations.  
**NOTE: The rail must be positioned to support the entire length of the mounting bracket.**
2. Remove the hole plugs from the roof and clean any gaskets and sealing material.
3. Coat the bottom of the rails with a quality silicone sealant and place the rails in position.
4. Coat the hole locations with sealant then attach each rail to the roof using 3 ea M6-20 screws, flat washers and nylock nuts.
5. Seal the edges of the rail.

**MOUNTING THE BRACKETS**

1. Mark the position of the awning.
  - 1.1. On the interior of the van, determine which roof cross members the awning will cover. Generally, the awning is placed forward to go over the sliding door. The front cross member will be the first cross member above the door.
  - 1.2. Detach any wiring that is routed along the cross members to avoid damage during drilling and installation.
  - 1.3. Using a common reference point such as the center of a mounting stud location for the sprinter rail, measure the location of the inner and outer edges of the cross member flanges inside the vehicle. Do this for each of the cross members that the awning brackets will sit across.
  - 1.4. Using a non-permanent method of marking, on the exterior (using the same reference point) measure and mark the locations of the inner and outer edges of the flanges.

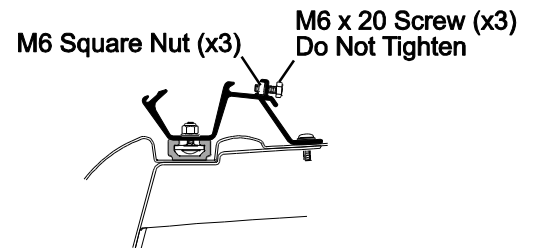
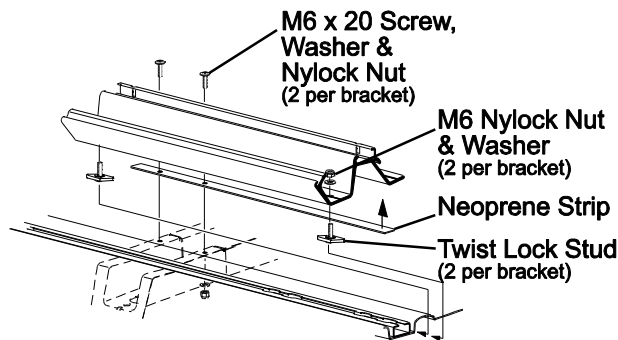
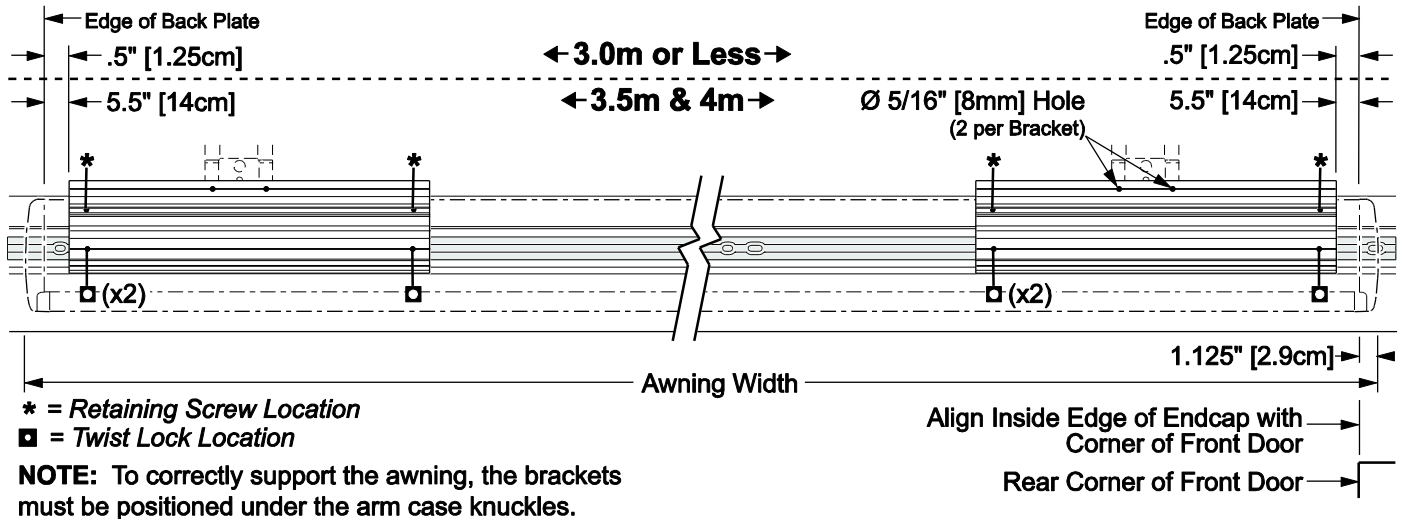
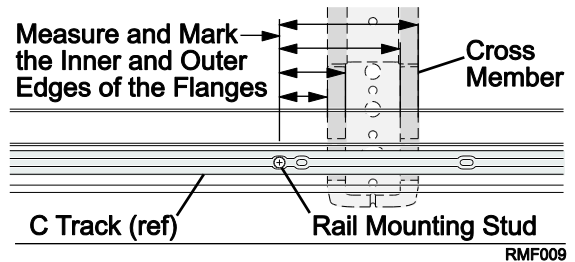

2. Remove the release paper from the neoprene strip and attach to the rear bottom face of the brackets. Trim for best fit.
3. On each bracket, loosely attach a twist lock stud with a flat washer and nylock nut to each end.
4. From one end of the track, slide the brackets onto the rail with the twist lock fasteners inside the rail.
5. Position the brackets on the roof.
  - 5.1. The brackets must straddle the roof cross members, they do not need to be centered over the cross members. Reference the marks made previously.
  - 5.2. Make sure that the outer edges of the brackets are within the dimension range (D) shown for the end of the awning. Adjust the bracket position as necessary.
6. Tighten the nuts for the twist lock fasteners.
7. For each bracket, drill two (2) 5/16" [8mm] holes through the bracket, roof and cross member flanges.
8. Secure the brackets to the roof using two (2) each M6 x 20 screws, flat washers and nylock nuts.
9. In the rear track of the mounting brackets, start three (3) M6 x 20 screws and square nuts through the retaining screw holes (these are marked with a "\*" in the above illustration). Do not tighten at this time.
10. Mount the awning according to the installation manual for the awning.