

# SWITCH REPLACEMENT KIT

**SINGLE SWITCH INSTALLATION KIT  
USED FOR 12V AWNINGS**

**Models:** Travel'r, Eclipse (single switch), Freedom Series Awnings, Marquee

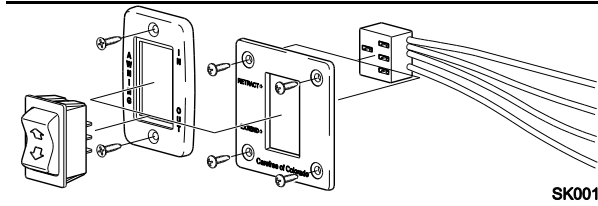

SK001

Switch  
Connector  
Narrow Switch Plate  
Square Switch Plate  
Screws

This kit includes two switch plates:

The narrow plate is for new installations and uses a rectangular hole to mount the switch or may be used for replacement of existing switches that uses the same plate.

The square plate is for new installations when a round mounting hole is preferred or may be used for replacement of existing switches that used a round mounting hole.

## NEW SWITCH INSTALLATION

1. Route the motor wires from the awning per the instructions in the awning installation manual.
2. Determine the switch plate style desired (see description above).
3. At the switch location:
  - 3.1. For the narrow switch plate (detail A), cut a rectangular hole 1.25" (3.2cm) x 1.88" (4.8cm) through the mounting surface.
  - 3.2. For the square switch plate (detail B), use a 2" (5cm) hole saw and cut a hole through the mounting surface.
4. Determine the switch orientation:
  - 4.1. The wires of the connector extend from the side of the switch with 3 terminals on the back.
  - 4.2. For wire routing on the right side of the switch as shown in Details A and B, orient the switch with the 3 terminals on the right.
  - 4.3. For wire routing on the left side of the switch as shown in Detail C, orient the switch with the 3 terminals on the left.
  - 4.4. Push the switch into the faceplate until the tabs on the switch "click" into place behind the faceplate. Ensure that the switch and faceplate are oriented so that the lettering is up and the wires are oriented as desired.
  - 4.5. Set switch aside and go to "Wiring the Connector on page 2.

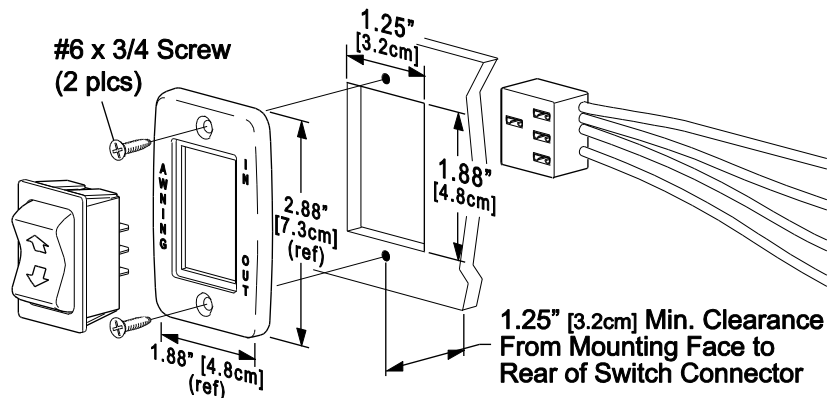

**DETAIL A** Narrow Plate w/ Right Side Orientation

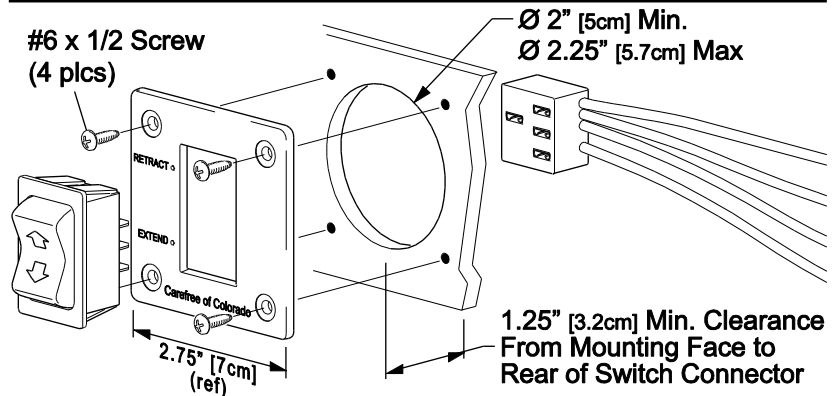

**DETAIL B** Square Plate w/ Right Side Orientation

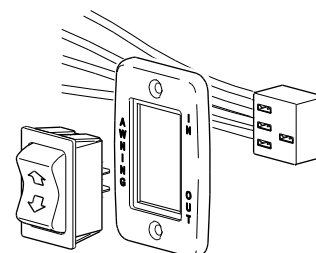

**DETAIL C**  
Example of Left Side Orientation

SK002

### REPLACING AN EXISTING SWITCH

This section is for replacing existing 4 terminal and 6 terminal rocker switches.

1. Remove the existing switch and switch plate.
2. Disconnect the wires. Make a note of which wires are the Power, Ground and Motor wires.
3. Remove any spade connectors that are on the wires.
4. Measure the existing mounting hole. The hole should be 2"-2.25" (5cm – 5.7cm) in diameter. If the hole is smaller than 2" in diameter, it will be necessary to enlarge the hole to the minimum 2" (5cm) diameter.
5. Determine the switch orientation (refer to details B & C on page 1):
  - 5.1. The wires of the connector extend from the side of the switch with 3 terminals on the back.
  - 5.2. For wire routing on the right side of the switch as shown in Details A and B, orient the switch with the 3 terminals on the right.
  - 5.3. For wire routing on the left side of the switch as shown in Detail C, orient the switch with the 3 terminals on the left.
  - 5.4. Push the switch into the square switch plate until the tabs on the switch "click" into place behind the faceplate. Ensure that the switch and faceplate are oriented so that the lettering is up and the wires are oriented as desired.
  - 5.5. Set switch aside and go to "Wiring the Connector on page 2.

### WIRING THE CONNECTOR

1. Route the awning motor wires through the switch hole and attach to the switch connector:

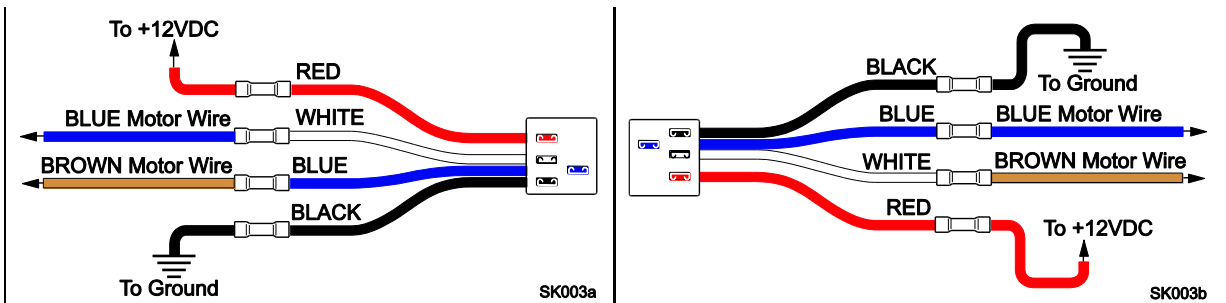

| CONNECTOR WIRE COLOR | LH CONNECTOR ORIENTATION |                    |            | RH CONNECTOR ORIENTATION |                    |            |
|----------------------|--------------------------|--------------------|------------|--------------------------|--------------------|------------|
|                      | Eclipse Travel'r         | Freedom WM Marquee | Freedom RM | Eclipse Travel'r         | Freedom WM Marquee | Freedom RM |
| RED→                 | +12VDC                   | +12VDC             | +12VDC     | +12VDC                   | +12VDC             | +12VDC     |
| WHITE→               | RED                      | BLUE               | BROWN      | BLACK                    | BROWN              | BLUE       |
| BLUE→                | BLACK                    | BROWN              | BLUE       | RED                      | BLUE               | BROWN      |
| BLACK→               | Ground                   | Ground             | Ground     | Ground                   | Ground             | Ground     |

2. Run a 16 awg (minimum) wire from the power distribution panel (auxiliary battery circuit) or equivalent. The circuit should be protected by a 15-amp fuse.
3. Run a 16 awg (minimum) wire to system ground.
4. Route the two wires through the mounting hole. Butt splice the 12VDC wire to the RED connector wire. Butt splice the ground wire to the BLACK connector wire.
5. Attach the connector to the switch.
6. Restore power and test the switch operation.
7. If the awning operates opposite to the switch plate markings:
  - Shut off power;
  - Reverse motor wires connected to the blue and white connector wires;
  - Restore power and test.
8. Push the wires, connector and switch into the mounting hole and secure the switch plate.
  - For the narrow plate, use two (2) #6 x 3/4" flat head screws.
  - For the square plate, use four (4) #6 x 1/2" oval head screws.