



SOKIII AND SOKIII XL

Product Style Codes: BC, BD, BE, BF, BH, BK, BL, BN, BP, UP, UQ, ZL, ZM

RV

SLIDEOUT COVER



Read this manual before servicing this product. Failure to follow the instructions and safety precautions in this manual can result in personal injury and/or cause the product to not operate properly.

This manual contains installation instructions for the standard SOKIII (units with lengths 191" or less), page 5; and the SOKIII XL (units longer than 191"), page 9.



TABLE OF CONTENTS

Installing an Awning Rail (if required):	4
Installation - Standard SOKIII	5
Component Checklist.....	5
Setting the Deflector Mounting Brackets	6
Adaptor Brackets	6
Mounting the Deflector Assembly	7
Installing the Roll Bar Assembly.....	7
Attaching the Front Cover	8
Cover Bumpers.....	8
Installation - SOKIII XL (OEM Model Only)	9
Component Checklist.....	9
Setting the Deflector Mounting Brackets	10
Mounting the Deflector Assembly	11
Installing the Roll Bar Assembly.....	12
Attaching the Front Cover	13

Cover Bumpers..... 13

PROPRIETARY STATEMENT

The SOKIII Slide-Out Cover is a product of Carefree of Colorado, located in Broomfield, Colorado, USA. The information contained in or disclosed in this document is considered proprietary to Carefree of Colorado. Every effort has been made to ensure that the information presented in the document is accurate and complete. However, Carefree of Colorado assumes no liability for errors or for any damages that result from the use of this document.

The information contained in this manual pertains to the current configuration of the models listed on the title page. Earlier model configurations may differ from the information given. Carefree of Colorado reserves the right to cancel, change, alter or add any parts and assemblies, described in this manual, without prior notice.

Carefree of Colorado agrees to allow the reproduction of this document for use with Carefree of Colorado products only. Any other reproduction or translation of this document in whole or part is strictly prohibited without prior written approval from Carefree of Colorado.

SAFETY INFORMATION



This is the safety alert symbol. It is used to alert individuals to potential personal injury hazards. Obey all safety messages that follow this symbol to avoid possible personal injury or death.



Indicates a hazardous situation, which if not avoided, could result in death or serious bodily injury.



Indicates a hazardous situation, which if not avoided, may result in minor or moderate bodily injury.



Indicates a situation that may result in equipment-related damage.

General Safety:



This product can expose you to chemicals including Di-isodecyl phthalate (DIDP), Vinyl Chloride and Formaldehyde, which are known to the state of California to cause cancer or birth defects or other reproductive harm. For more information visit www.P65warnings.ca.gov



Shock Hazard. Always disconnect battery or power source before working on or around the electrical system.



Always wear appropriate safety equipment (i.e. goggles).



Always use appropriate lifting devices and/or helpers when lifting or holding heavy objects.



When using fasteners, do not over tighten. Soft materials such as fiberglass and aluminum can be "stripped out" and lose the ability to grip and hold.

INSTALLING AN AWNING RAIL (IF REQUIRED):

NOTES:

- a) The awning rail for the XL is shipped in two pieces.
- b) Clean and deburr the mating ends of the rails so that there are no sharp edges at the joint.
- c) When mounting the rails, make sure that the two pieces are aligned and straight.

If it is necessary to mount an awning rail:

1. Position the awning rail along the roofline (line where roof and wall meet) or 1"-2" above the room flange. The awning rail must be level and parallel with the room.
2. Seal the back of the rail with silicone sealant or putty tape.
3. Align the centerline of the awning rail. Attach the rail using #10 x 3/4 screws.

To aid sliding the fabric into the awning rail:

4. Using a screwdriver slightly spread open one end of the awning rail.
5. Spray inside the awning rail track with silicone lubricant.

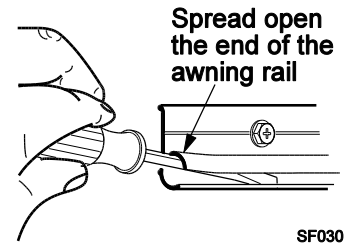

INSTALLATION - STANDARD SOKIII

COMPONENT CHECKLIST

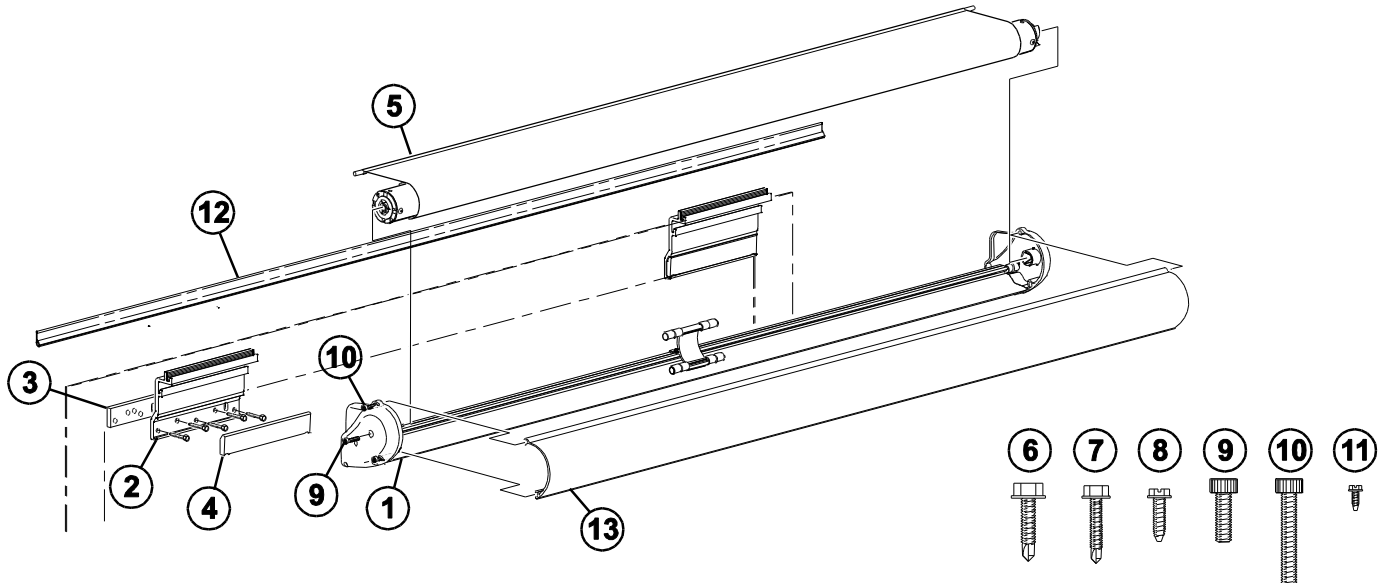

ITEM	DESCRIPTION	QTY	NOTE
<input type="checkbox"/> 1	Deflector Assy	1	
<input type="checkbox"/> 2	Bracket, Deflector Assy, Short	NOTE	3
<input type="checkbox"/> 3	Shim, 1/4", Deflector Bracket	NOTE	1
<input type="checkbox"/> 4	Cover, Bracket, Deflector Assy	1 per bracket	
<input type="checkbox"/> 5	Roll Bar Assy	1	
<input type="checkbox"/> 6	Screw, Self Drilling, HWH	#12 x 1	10
<input type="checkbox"/> 7	Screw, Self Drilling, HWH	#10 x 1	4
<input type="checkbox"/> 8	Screw, HWH, Thread Type A	#10 x 3/4	51
<input type="checkbox"/> 9	Screw, Socket Head, Roll Bar (this screw shipped installed)	1/4-20 x 3/4	1
<input type="checkbox"/> 10	Screw, Socket Head, Cover (2 screws are shipped installed)	1/4-20 x 1 1/2	4
<input type="checkbox"/> 11	Screw, Self Tapping, HWH	#6 x 3/8	2
<input type="checkbox"/> 12	Awning Rail	1	
<input type="checkbox"/> 13	Front Cover Assy	1	2

SOKiii001

- NOTES:
- Bracket Shim (item 3) is optional and must be specified at time of order.
 - The Front Cover Assembly is optional and specified at time of order.
 - Quantity of brackets: 2 for units 155" or less; 3 for units 156" - 191". Dimensions are based on order length not overall length

- Unpack the shipping cartons and remove the front cover (if installed). The cover is attached by two (2) socket head screws (1 per end cap); back the screws out until the end of the screw clears the edge of the cover. It is not necessary to remove the screws from the end caps.
- The roll bar assembly is shipped in the deflector assembly. Remove the allen head screw and save, DO NOT DISCARD. Remove the left end of the roll bar then slide the right end out. Remove packing material.

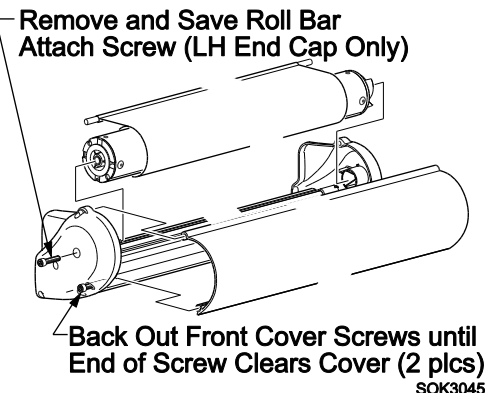

SETTING THE DEFLECTOR MOUNTING BRACKETS

Adaptor Brackets

Some vehicles may have competitor's "prep brackets" installed for mounting their shorter slideout awnings. The Carefree Slide Topper Prepped Access Plate Adapter Kit (BX0013-2-WHT or BX0013-2-BLK) allows installers to mount Carefree slideout awnings on these "prep brackets". Refer to installation supplement "070045-001 BX0013 Carefree Slide Topper Prepped Access Plate Adapter Kit" for mounting instructions using the adaptor kit brackets.

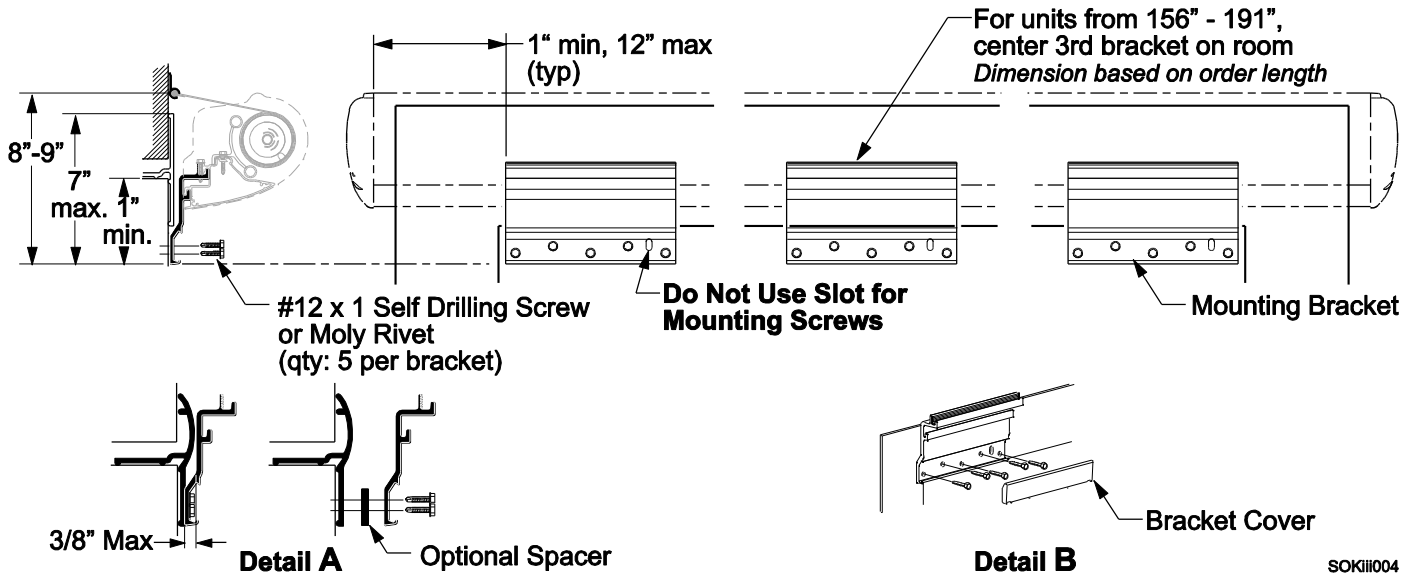
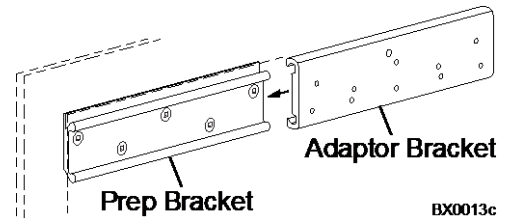

NOTE: If the thickness of the room flange exceeds the 3/8" maximum as shown in detail A, a 1/4" spacer is available. Spacer is ordered separately.

- Vertically position the bottom of deflector brackets on the room face 8"-9" below the centerline of the awning rail. Horizontally position the brackets as shown above.

NOTE: The bottom of the brackets must not be positioned more than 7" below the top of the flange or less than 1" from the top of the room

- Attach the brackets.
 - Using a quality silicone sealant, coat the mounting surface of the bracket with particular attention around the mounting holes.
 - If attaching into structure, position the brackets and optional shims (if used) and attach using five (5) #12 x 1 self-drilling screws.
 - Where there is no structure for the screws, use moly rivets. Moly rivets require a 1/4" pilot hole.
- Snap the bracket cover on to the bracket to cover the screw heads. The tab on the back of the cover goes into the slotted hole of the bracket.

NOTE: If it is necessary to remove the cover after installation, slide a small pin (e.g. paper clip) in the end under the cover. Lift the locking tab and gently pull out the end of the cover. Repeat for other side of the cover.

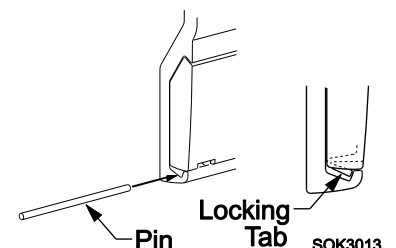

MOUNTING THE DEFLECTOR ASSEMBLY

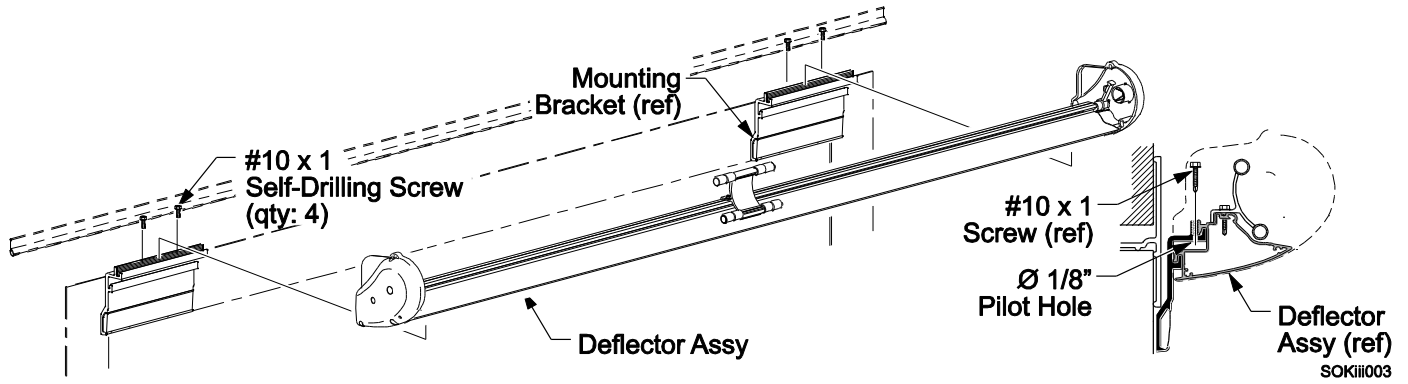

1. Lift the deflector assembly up and onto the mounting brackets. The deflector hooks into the brackets.
2. Horizontally center the assembly over the room.
3. In the screw groove formed between the bracket and deflector, drill a 1/8" pilot hole through the bottom of the bracket in the screw groove. If the deflector moves during drilling, complete the drilling operation then realign the deflector in the brackets.
4. Secure the deflector assembly to the bracket using four (2 per bracket) #10 x 1 self-drilling screws.

INSTALLING THE ROLL BAR ASSEMBLY

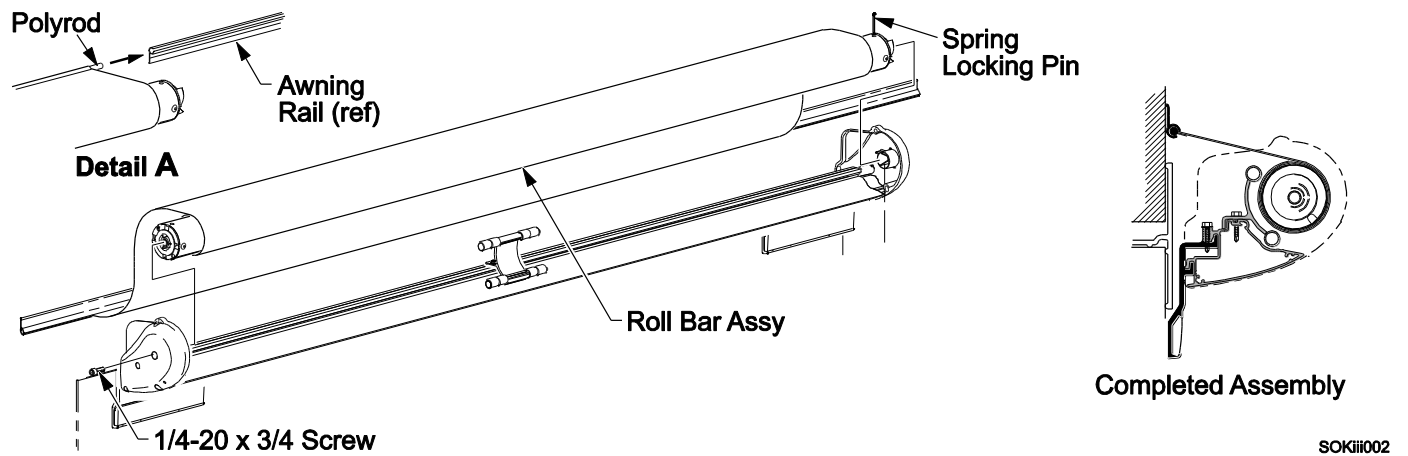

1. Close the room if open.
2. Unroll some of the fabric from the roll bar.
3. Slide the polyrod and fabric into the awning rail. Center the fabric over the room.
4. Roll up the slack material onto the roll bar.

NOTICE Failure to roll up the slack before installing the roller tube will reduce the spring tension. Reduced spring tension may cause the fabric to sag and not roll up correctly when the room is closed.

5. Slide the right end of the roll bar into the right end cap then set the left end of the roll bar into the left end cap. Attach with one (1) 1/4-20 x 3/4 socket head screw through the left end cap.
6. Remove the spring locking pin from the roll bar. This is located on the right end of the roll bar.
7. Open and close the room to ensure that the fabric is rolling up straight on the roller tube.
8. Secure the fabric to the awning rail using two #6 x 3/8 screws through the rail and fabric.

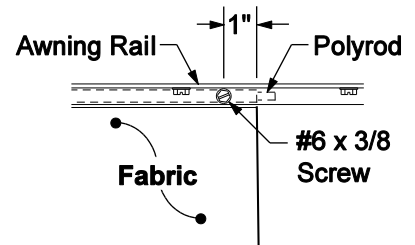
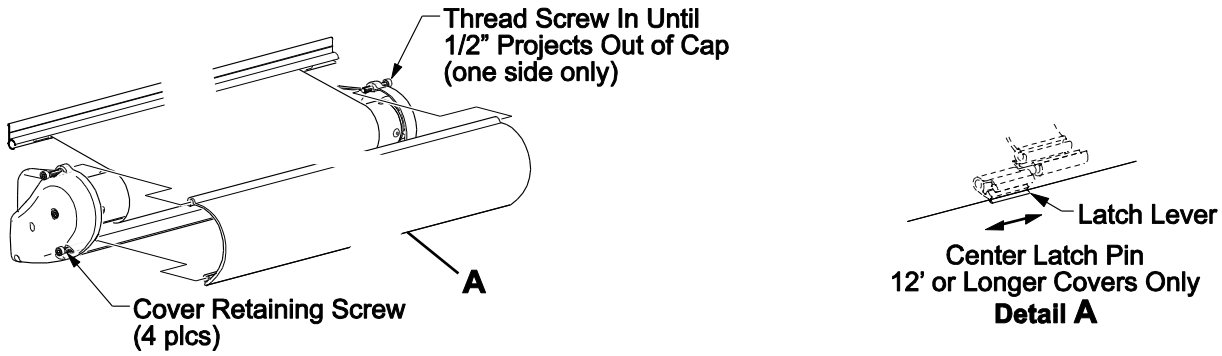

Figure 1. Securing the Fabric.

ATTACHING THE FRONT COVER



SOK3046

1. If removed, thread the 1/4-20 x 1 1/2 socket head screws into the end caps. On one side thread the screws until flush with the inside of the end cap. On the other side, thread the screws until they project out of the end cap approximately 1/2".
NOTE: The bottom screw holes are threaded at the factory. It will be necessary to force-thread the top holes in the end cap using the supplied screws.
2. Lift the cover up and place one end over the screws that project out of the end cap. The screws fit into the slots of the cover.
3. Align the cover with the other end cap and thread in all the attach screws thru the end caps and into the cover. Hand tighten only.
4. *For covers 12 feet and longer:* Locate the latch lever at the center of the cover. Using a screw driver or similar tool, push the lever to the left and hold; press the cover into position then release the latch lever. The latching pin is spring loaded and will slide into the locking channel.

Cover Bumpers

The SOK III cover is shipped with bumpers to prevent rattling. Quantities are two (2) for units under 10"; three (3) for units 10' to 12' and five (5) for units 12' and longer.

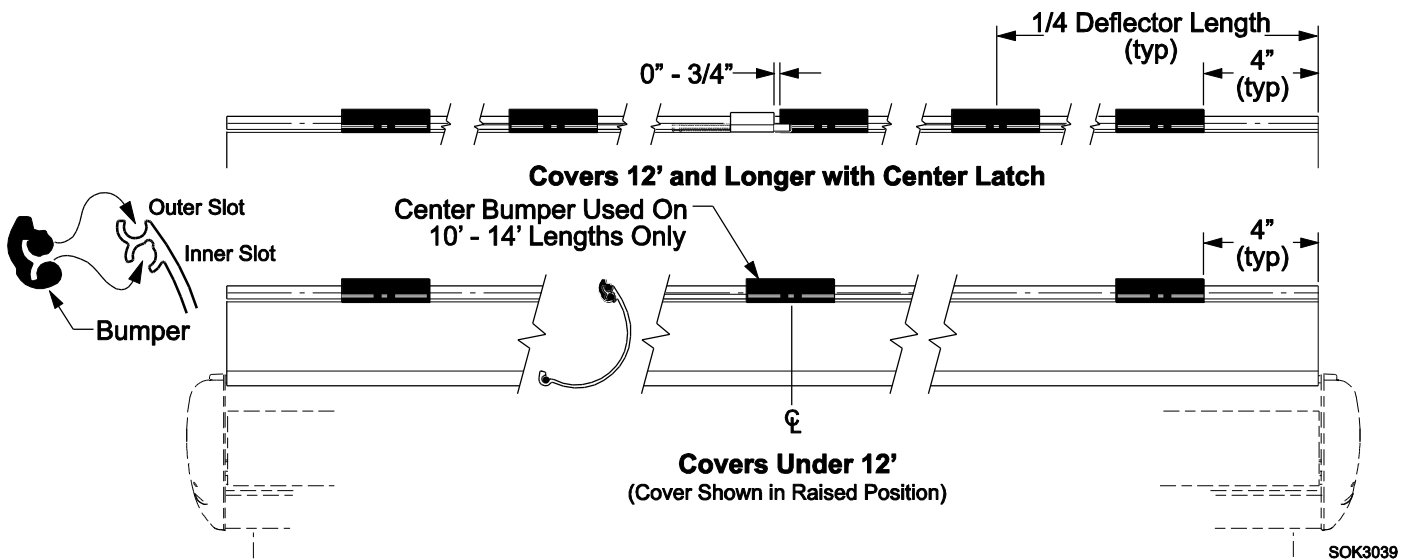

SOK3039

To replace missing or damaged bumpers:

1. In the positions shown, fully press the first round section into the inner slot. This is the same slot that the cover retaining screws are mounted in. Please note the orientation of the bumper.
Tip: Press one end of the bumper into the slot. While holding the bumper in place, gently stretch the bumper. This will temporarily make the diameter smaller and easier to press into the slot.
2. Stretch the bumper around and press the second round section into the outer slot.

INSTALLATION - SOKIII XL (OEM MODEL ONLY)

COMPONENT CHECKLIST

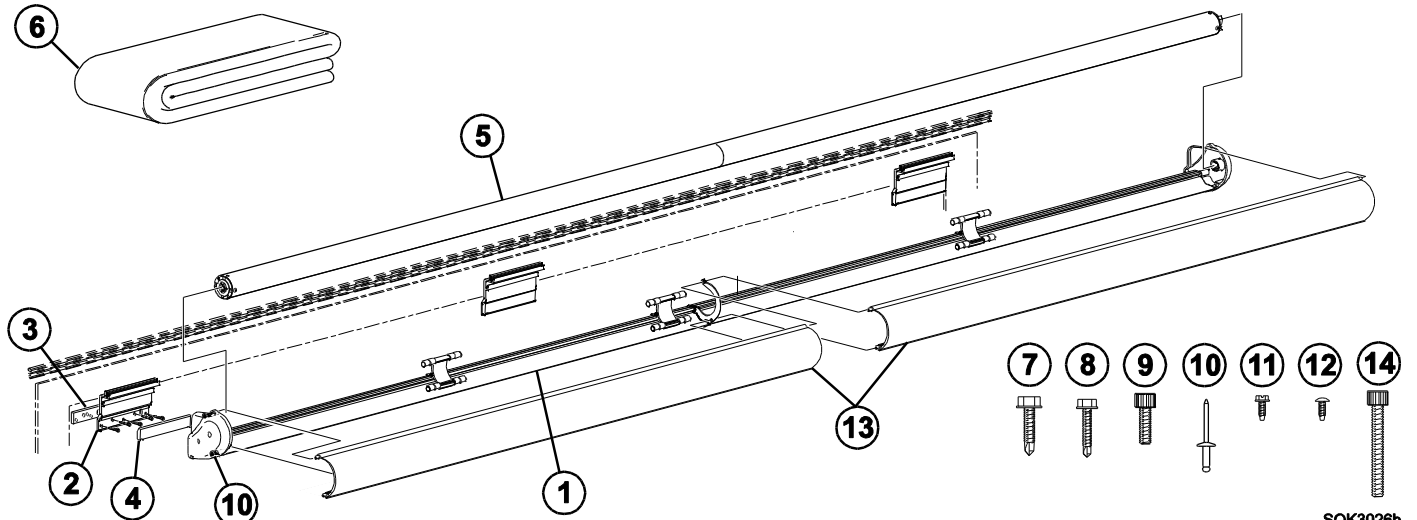

U	ITEM	DESCRIPTION		QTY	NOTE
<input type="checkbox"/>	1	Deflector Assy		1	2
<input type="checkbox"/>	2	Bracket, Deflector, Short		3	3
<input type="checkbox"/>	3	Spacer, 1/4", Deflector Bracket		3	3,4
<input type="checkbox"/>	4	Cover, Bracket, Deflector Assy		3	
<input type="checkbox"/>	5	Roll Bar Assy		1	2
<input type="checkbox"/>	6	Fabric		1	
<input type="checkbox"/>	7	Screw, Self Drilling, HWH	#12 x 1	15	
<input type="checkbox"/>	8	Screw, Self Drilling, HWH	#10 x 1	6	
<input type="checkbox"/>	9	Screw, Socket Head	1/4-20 x 3/4	1	
<input type="checkbox"/>	10	Pop Rivet	3/16	4	
<input type="checkbox"/>	11	Screw, Self Tapping, HWH	#6 x 3/8	2	
<input type="checkbox"/>	12	Screw, Phillips Head	#6 x 3/8	2	
<input type="checkbox"/>	13	Front Cover Assy		1	2
<input type="checkbox"/>	14	Screw, Socket Head (2 screws are shipped installed in end caps)	1/4-20 x 1 1/2	4	

- Notes:
- Specific configurations are specified at time of order, including awning length, fabric, color etc. Check awning assembly against original purchase order.
 - Deflector assy (item 1), Roll Bar assy (item 4), and Front Cover assy (item 14) are shipped in two sections and assembled during installation.
 - For rooms 283" or longer, quantity of brackets (items 2) is 5.
 - Bracket Shim (item 3) is optional and must be specified at time of order.

SETTING THE DEFLECTOR MOUNTING BRACKETS

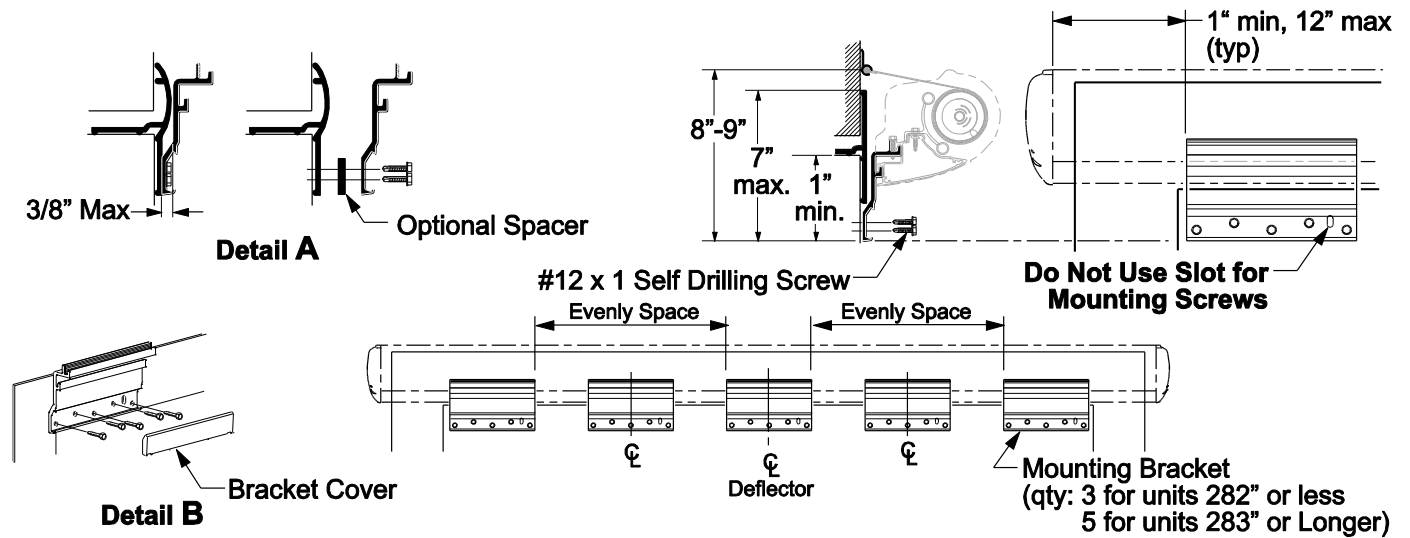

NOTE: If the thickness of the room flange exceeds the 3/8" maximum as shown in detail A, a 1/4" spacer is available. Spacer is ordered separately.

- Vertically position the bottom of deflector brackets on the room face 8"-9" below the centerline of the awning rail. Horizontally position the brackets as shown above.

NOTE: The bottom of the brackets must not be positioned more than 7" below the top of the flange or less than 1" from the top of the room

- Horizontally position the brackets as shown above. The center bracket must be positioned so that the center splice of the deflector will rest near the center of the bracket. For units with 5 brackets; the middle brackets may be adjusted $\pm 12"$ to avoid vents or other projections.
- Attach the brackets.
 - Using a quality silicone sealant, coat the mounting surface of the bracket with particular attention around the mounting holes.
 - Use #12 x 1 self-drilling screws. (5 per bracket).
- Snap the bracket cover on to the bracket to cover the screw heads. The tab on the back of the cover goes into the slotted hole of the bracket.

NOTE: If it is necessary to remove the cover after installation, slide a small pin (e.g. paper clip) in the end under the cover. Lift the locking tab and gently pull out the end of the cover. Repeat for other side of the cover.

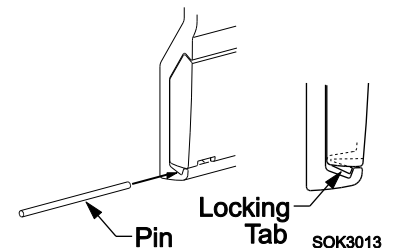

MOUNTING THE DEFLECTOR ASSEMBLY

The deflector is shipped in two sections. The RH section has the RH end cap and the center splice assembly. The LH section has the LH end cap only.

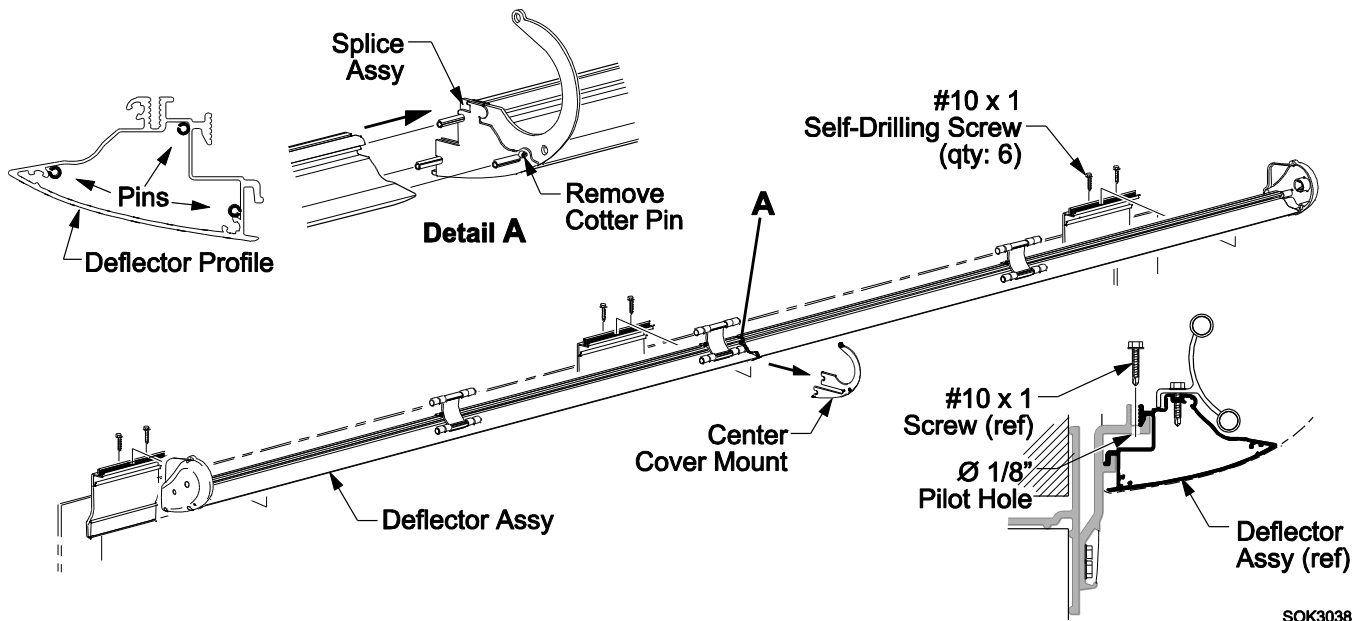

5. Lift the RH deflector assembly up and onto the mounting brackets. The deflector hooks into the brackets.
6. Horizontally align the center splice assembly with the centerline of the room. This should coincide with the center line of the center mounting bracket.
7. In the screw groove formed between the RH bracket and deflector, drill a 1/8" pilot hole through the bottom of the bracket in the screw groove. Secure the assembly to the bracket using two (2) #10 x 1 self drilling screws. If the deflector moves during drilling, complete the drilling operation then realign the deflector. Do not attach the deflector to the center bracket at this time.
8. From the splice assembly, remove the cotter pin and the center cover mount. Set both components aside to reinstall later.

NOTE: The cover mount is not installed if the optional cover is not to be installed.

9. Lift the LH section of the deflector up and onto the brackets.
10. Align the LH section with the RH section and press the LH section onto the split pins of the splice assembly.

Tip: The split pins are a tension fit. If necessary, remove the LH end cap and set aside. Use a rubber mallet and tap the LH section onto the pins. Use care to not bend or distort the deflector. When the inner end is tight against the splice assembly, reattach the end cap.

11. For the left and center brackets: In the screw groove formed between the bracket and deflector, drill a 1/8" pilot hole through the bottom of the bracket in the screw groove. Secure the assembly to the brackets using #10 x 1 self drilling screws (2 per bracket).

INSTALLING THE ROLL BAR ASSEMBLY

NOTICE Because of the length and weight of the roller tube and fabric, it will be necessary to have 3 people to install the roller tube; one person at each end, with the third person to support the center.

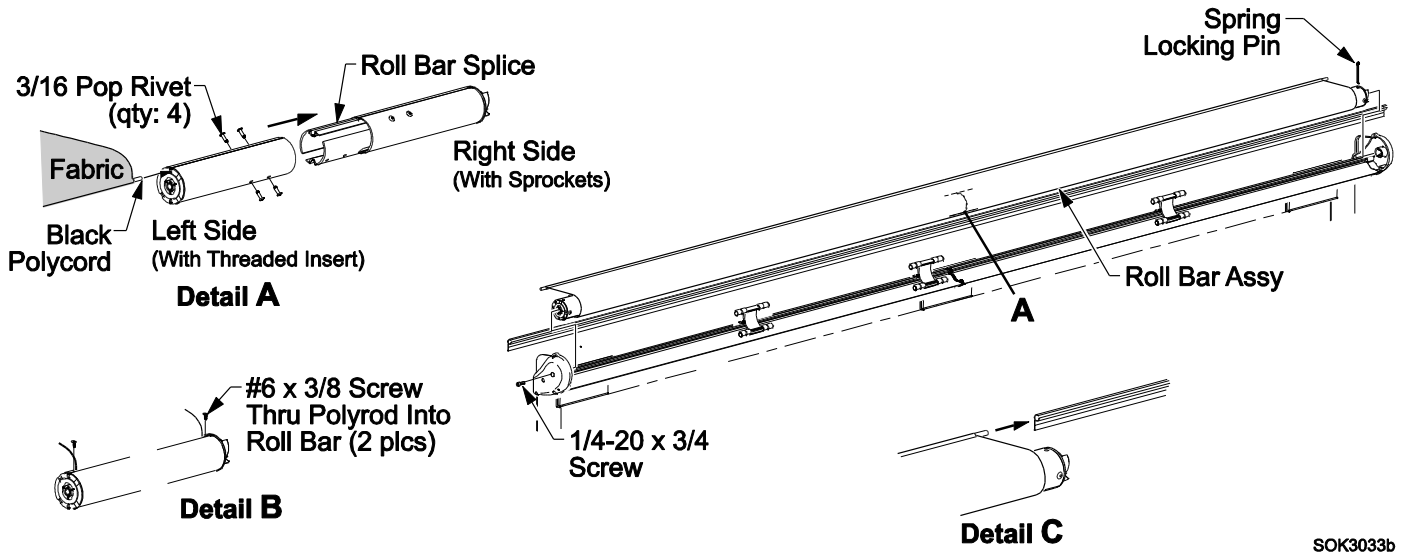

SOK3033b

9. Close the room if open.
10. (Detail A) Slide the two roll tube halves together. The splice is a tension fit. It may be necessary to tap one end of the roll tube to press the two halves together. Align the predrilled rivet holes in the roll tube and splice.

NOTICE Use care to not bend or distort the roller tube. If it is necessary to tap the end of the roll bar, use care to not damage the endcap.

11. Attach the roll bar half to the splice using four (4) 3/16" pop rivets.

NOTE: If the rivets holes are slightly misaligned, use a #10 drill bit and ream the holes to allow the pop rivet to be pushed in.
12. Unfold the fabric and slide the edge of the fabric (edge with black polycord) into the roller tube. The fabric can only be inserted from the left side of the roller tube.
13. (Detail B) Center the fabric on the roll bar and secure using two (2) #6 x 3/8 phillips head screws through the polycord and roller tube. Do not put the screws through the fabric.
14. Roll the fabric onto the roller tube. The fabric must be oriented around the roll bar as shown.
15. (Detail C) Slide the white polyrod and fabric into the awning rail. Center the fabric over the room.
16. Roll up the slack material onto the roll bar.

NOTICE Failure to roll up the slack before installing the roller tube will reduce the spring tension. Reduced spring tension may cause the fabric to sag and not roll up correctly when the room is closed.

17. Slide the right end of the roll bar into the right end cap then set the left end of the roll bar into the left end cap. Attach with one (1) 1/4-20 x 3/4 socket head screw through the left end cap.
18. Remove the spring locking pin from the roll bar. This is located on the right end of the roll bar.
19. Open and close the room to ensure that the fabric is rolling up straight on the roller tube.
20. Secure the fabric to the awning rail using two #6 x 3/8 screws through the adaptor and fabric.

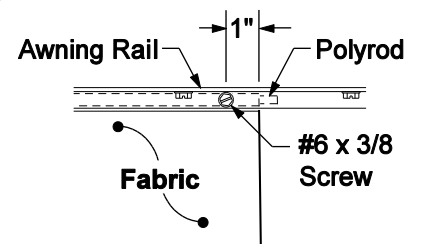

SOK3034a

ATTACHING THE FRONT COVER

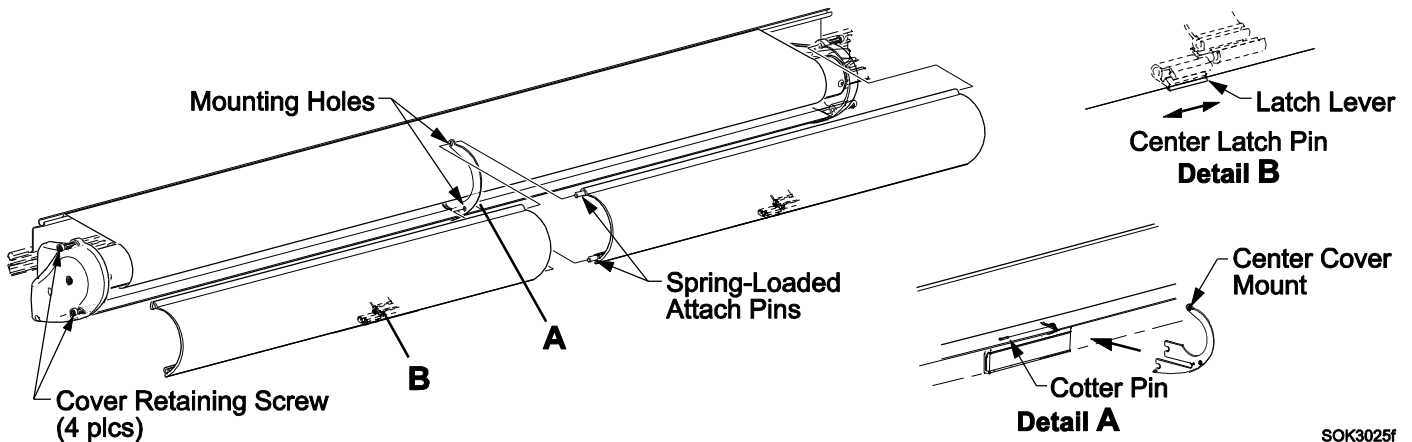

SOK3025f

5. Insert the center cover mount into the deflector splice and around the rolled fabric. Secure with the cotter pin removed earlier.
6. Examine the two cover halves. One half has spring loaded attachment pins on one end, the second has none. Lift the first cover half with the pins and insert the pins through the mounting holes of the center cover support.
7. Align the cover with the end cap and screw the cover retaining 1/4-20 x 1 1/2 socket head screws through the end cap and into the cover. Hand-tighten only.

NOTE: The bottom screw holes in the end caps are threaded at the factory. It will be necessary to force-thread the top holes in the end cap using the supplied screws.

8. Lift the second cover half up and slide the inside end onto the protruding attach pins of the first cover.
9. Align the second cover with the end cap and screw the cover retaining screws through the end cap and into the cover. Hand-tighten only.
10. Locate the latch lever at the center of the covers. Using a screw driver or similar tool, push the lever to the left and hold; pres the cover into position then release the latch lever. The latching pin is spring loaded and will slide into the locking channel.

Cover Bumpers

The SOKIII cover is shipped with bumpers to prevent rattling. Quantities are three (3) for units under 14' and five (5) for units 14' and longer.

To replace missing or damaged bumpers:

3. In the positions shown, fully press the first round section into the inner slot. This is the same slot that the latch springs are mounted in. Please note the orientation of the bumper.

Tip: Press one end of the bumper into the slot. While holding the bumper in place, gently stretch the bumper. This will temporarily make the diameter smaller and easier to press into the slot.

4. Stretch the bumper around and press the second round section into the outer slot.

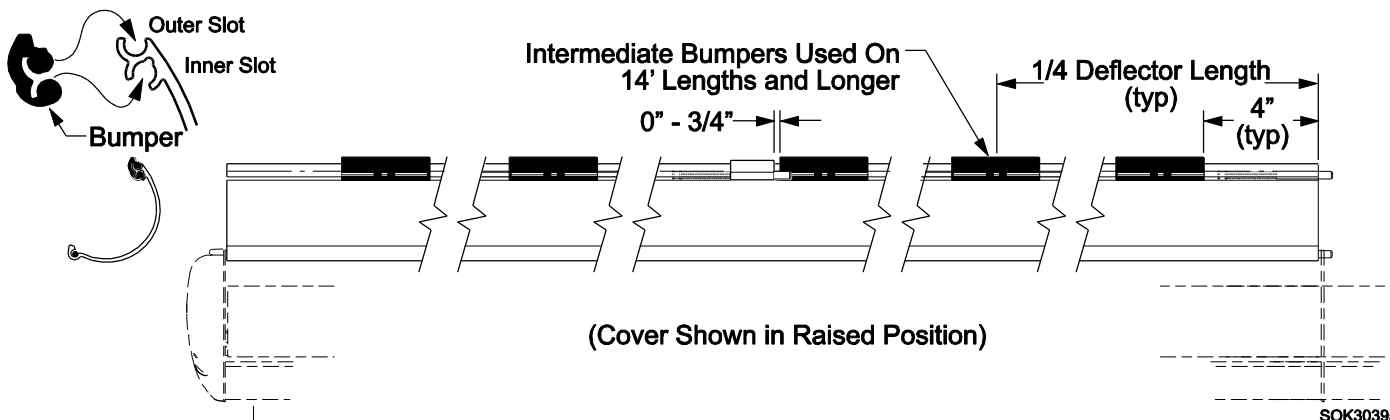

SOK3039a

OEM Representative (please print)

OEM Signature

OEM Position

Date

Carefree Representative (please print)

Carefree Signature/Date

Disclaimer: Carefree performs audits as a service for our customers to help identify situations where installations may not conform to installation instructions, and to identify any potential installation errors. Audits are a random, one-time checkin time and do not verify all the attributes specified in the installation instructions. Carefree cannot be held responsible for any damage or costs as a result of incorrect installation. OEMs must always install products according to installation instructions. This document does not constitute liability or culpability on Carefree’s part for incorrect installations performed by the OEM, dealer, service provider or the consumer.