



Service Manual - Marquee

Product style codes: 34, 43, 48, 89

WINDOW AND OVER THE DOOR (OTD) AWNINGS



Read this manual before installing or servicing this product. Failure to follow the instructions and safety precautions in this manual can result in personal injury and/or cause the product to not operate properly.

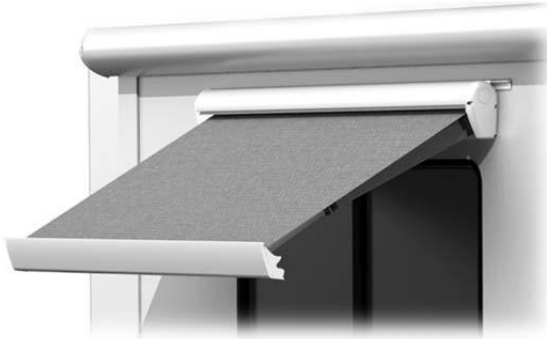

Window



OtD

TABLE OF CONTENTS

Product Overview	1
Canopy Replacement	2
Spring Arm Replacement	3
Replacing the Lead Rail Connector	4
Replacing the Case Connector.....	4
Motor Replacement	5
Preliminary Steps	5
Motor Replacement w/ 2-Slot Roller Tube (kit no. R001531)	5
Motor Replacement w/ 3-Slot Roller Tube (kit no. R001651)	7
Setting the Motor Limits	8
Out Limit Switch	8
IN Limit Switch	8
Wiring Diagrams	9
Switch Installation – No Relay	9
Switch Installation w/ Relay Module.....	10
Removing the Awning	10
Manual Override	11
Standard Maintenance	11
Fabric Care	11

Arm Care.....	12
Motor Maintenance.....	12
Part Number Listing.....	12
Part Number Location.....	12
Illustrated Parts List (<i>Units Built Prior to July 2010</i>).....	13
Illustrated Parts List (<i>Units Built After to July 2010</i>).....	14

Printed in USA

March 2026

PROPRIETARY STATEMENT

The Marquee Awning is a product of Carefree of Colorado, located in Broomfield, Colorado, USA. The information contained in or disclosed in this document is considered proprietary to Carefree of Colorado. Every effort has been made to ensure that the information presented in the document is accurate and complete. However, Carefree of Colorado assumes no liability for errors or for any damages that result from the use of this document.

The information contained in this manual pertains to the current configuration of the models listed on the title page. Earlier model configurations may differ from the information given. Carefree of Colorado reserves the right to cancel, change, alter or add any parts and assemblies, described in this manual, without prior notice.

Carefree of Colorado agrees to allow the reproduction of this document for use with Carefree of Colorado products only. Any other reproduction or translation of this document in whole or part is strictly prohibited without prior written approval from Carefree of Colorado.

SAFETY INFORMATION

This is the safety alert symbol. It is used to alert individuals to potential personal injury hazards. Obey all safety messages that follow this symbol to avoid possible personal injury or death.

Indicates a hazardous situation, which if not avoided, could result in death or serious bodily injury.



Indicates a hazardous situation, which if not avoided, may result in moderate to serious bodily injury.



NOTICE Indicates a situation that may result in equipment-related damage. **General Safety:**



This product can expose you to chemicals including Di-isodecyl phthalate and Formaldehyde, which are known to the state of California to cause cancer or birth defects or other reproductive harm. For more information visit www.P65warnings.ca.gov

Shock Hazard. Always disconnect battery or power source before working on or around the electrical system.



WARNING

Always wear appropriate safety equipment (i.e. goggles).



CAUTION

Always use appropriate lifting devices and/or helpers when lifting or holding heavy objects.



NOTICE When using fasteners, do not over tighten. Soft materials such as fiberglass and aluminum can be "stripped out" and lose the ability to grip and hold.

PRODUCT OVERVIEW

The Marquee Window and OtD (Over the Door) Awnings are state of the art lateral arm awnings. When retracted, the housing provides protection against the elements while the streamlined styling blends in with the coach side wall. The full tension canopy fabric allows the awning to be partially or fully extended for best shade coverage. No vertical arms interfere with coach sidewalls, custom graphics or equipment that may be mounted on the sidewalls.

Awning Specifications:

- Fully retractable and self storing;
- The sealed awning motor operates on standard 12VDC (range 10VDC to 14VDC); □ Fabric is woven acrylic;
- Case and frame are constructed of high-strength aluminum extrusions, protected with a polyester paint finish; □ Stainless steel fasteners and hardware.

EXTENSION: 36"	AVAILABLE WIDTHS:	<i>OtD</i>	44" - 72"
		<i>Window</i>	44" - 156"

LEADING EDGE POSITION ACTUATION AND CONTROL

<i>Power:</i>	Lateral Arm Spring	
<i>Minimum Tension</i>	Open	
<i>Position Control:</i>	<i>Motorized:</i>	Roll Out/In Controlled by Electrical Motor

MOTOR SPECIFICATIONS

<i>Motor Type:</i>	Tubular		
<i>Power:</i>	12VDC	<i>Minimum:</i> 8VDC	<i>Output:</i> 30 Watts
	<i>Nominal Current:</i> 2.5Amps		<i>Max Current:</i> 14Amps (stall @ min voltage)
<i>Power Source:</i>	Motor and controls are routed and hardwired into the vehicle's 12V system		
<i>Torque</i>	<i>Continuous:</i> 6Nm/4.5 ft-lbs.		<i>Tightening:</i> 18Nm/13.2 ft-lbs.
<i>Speed</i>	15 rpm		

COLORS AVAILABLE

<i>Case</i>	Standard: White, Black
<i>Fabric</i>	Woven Acrylic Fabric (refer to sales literature for colors available)

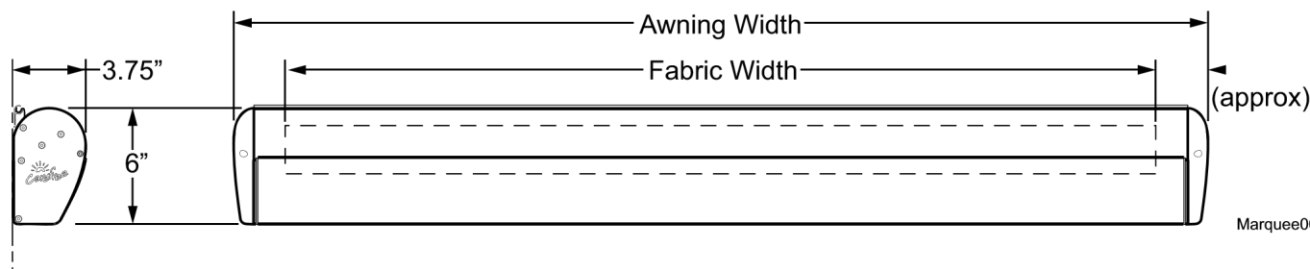
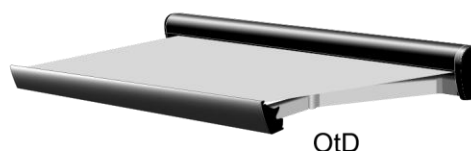

CANOPY REPLACEMENT

1. Open the awning several inches to expose the arm elbows.
2. (Refer to Detail A) Using a minimum 1/2" rope, firmly tie the elbows of the spring arms together, do not use bungee cords. When tying the rope, use a non-slip knot such as a square knot or equivalent.

CAUTION Failure to secure the lead rail as described will allow the spring arms to unexpectedly extend out possibly causing personal injury and damage to the awning.

3. Use the extend button to unroll the canopy until the fabric slot in the tube is aligned with the awning case opening.

4. Disconnect power to the awning.
5. Remove the idler side end cap and lead rail end plate and set aside.
6. On the opposite end of the lead rail, remove the fabric retaining screw (middle screw) from the end plate.

NOTICE It will be necessary to firmly support the roll bar and keep it from coming out of the case and off of the motor during the next steps.

7. From the idler end of the roller tube, simultaneously slide the old canopy out of the roller tube and lead rail.
8. Inspect the slots in the roll bar and lead rail. Clean and deburr as required. Lightly spraying the inside of the slots with a dry silicone lubricant will aid in sliding the new fabric in.
9. Slide the new canopy into the lead rail and roller. Both edges must be done at the same time. Orient the fabric so that the large polycord goes into the lead rail, the smaller polycord goes into the roll bar. The hem should be on the down side.
10. Center the canopy into the slots of the roller tube and lead rail.
11. Remove any support material from the roller tube and attach the case end cap.
12. Restore power to the awning and roll the canopy onto the roller tube. The fabric rolls under the roll bar. Ensure the fabric rolls evenly onto the roller tube without wrinkling or folding.
13. Once the fabric is rolled taut, remove the rope used to tie the arms together.
14. Extend the awning.
15. Attach the lead rail end plate using the top and bottom screws only.
16. Center the canopy into the slots of the roller tube and lead rail.
17. Hold the fabric in place and attach using the fabric retaining screw (middle screw) through one lead rail end plate.
18. On the opposite end of the lead rail, stretch the fabric smooth and attach using the fabric retaining screw (middle screw) through the end plate.

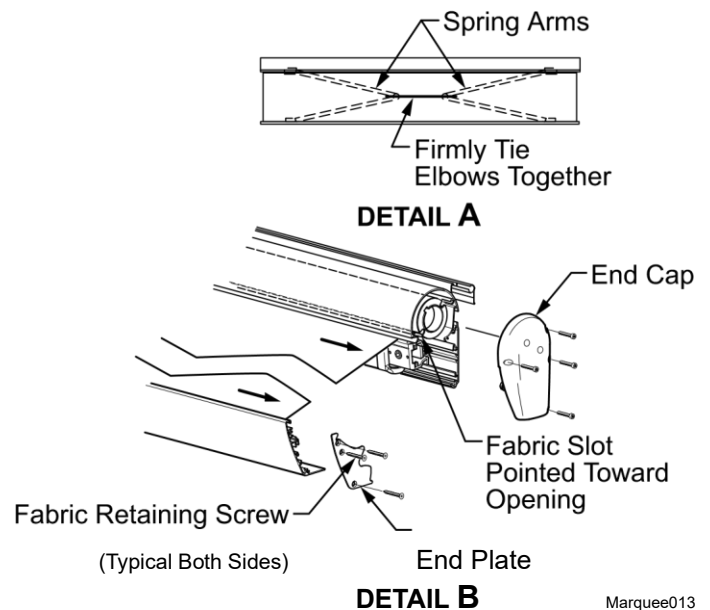

Marquee013

19. After replacing the canopy, it will be necessary to adjust the motor limits. Follow the procedure on page 6.

SPRING ARM REPLACEMENT



CAUTION

The spring arm is under tension to open. Use extreme care to firmly hold the spring arms during assembly and disassembly to avoid any sudden or unexpected movement by the arm. Serious personal injury and /or property damage could occur.

NOTE: On replacement arms, the connector assemblies are not included and must be ordered separately if the parts are to be replaced.

The following procedure requires two people.

1. Open the awning to the maximum extension or as wide as possible. This is to minimize the spring tension in the arms during this procedure.
2. Disconnect power to the awning.
3. Use a scaffold, ladder or other means to firmly support the lead rail.
4. (refer to *Detail A*) At the lead rail, remove the e-ring and rotation pin from the arm and connector assembly.

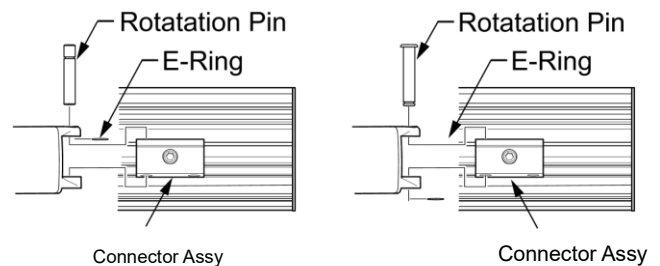
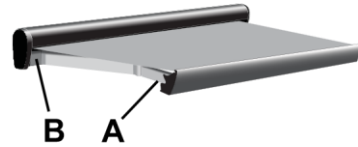

NOTE: For early configurations, the e-ring is located Early Pin Configuration Current & Replacement Pin Configuration between the arm clevis and the connector. Newer Pin Configuration arms and replacements use a stepped pin with the e-**Detail A** ring located at the end of the pin. **(Lead Rail Connector)**

5. Firmly grasp the spring arm and allow the arm to extend to its maximum length outside the lead rail. Have a second person hold or otherwise support the unattached end.
6. (refer to *Detail B*) Inside the case, remove the 6-32 x .25 set screw from the case connector and save.
7. Remove the rotation pin and arm from the awning.

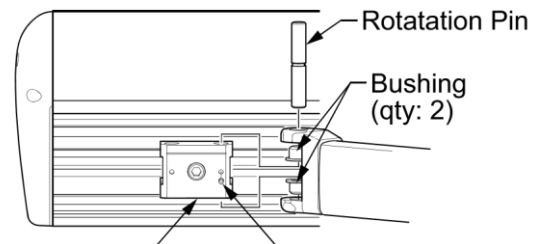

Connector Assy **Detail B** 6-32 x .25 set screw

8. Remove the bushings from the flanges from the arm. **(Case Connector)** Marquee010
9. *If replacing the lead rail connector or case connector, go to page 4 then return to step 10.*
10. Firmly hold the ends of the new arm assembly and remove the shipping ties. Allow the arm to slowly open to its maximum extension.



CAUTION

When the arm is closed, it can open with significant force. Use care when opening the arm.

11. Insert the two bushings into the rear flanges of the new arm assy.
12. Lift the new arm up and position the rear arm flanges over the case connector.
13. Slide the rotation pin through the arm flanges and case connector. Align the groove in the pin with the set screw hole in the connector bracket.

14. Secure the pin in place with the 6-32 x .25 set screw removed previously.
15. Carefully bend the arm and place the front flanges of the arm over the lead rail connector.
16. Attach the arm using the rotation pin and e-ring removed previously. The e-ring goes into the groove of the pin and between the top of the connector and upper flange.
17. Restore power and test operation.

REPLACING THE LEAD RAIL CONNECTOR

1. Carefully mark the location of the existing connector in the lead rail. Make note of the bracket orientation.
2. Remove the lead rail end plate.
3. Loosen the large hex screw in the center of the bracket and slide the out bracket out of the lead rail.
4. Insert the new connector assembly into the lead rail and position at the marks made previously.
5. Tighten the securing screw.
6. Attach the lead rail end plate.

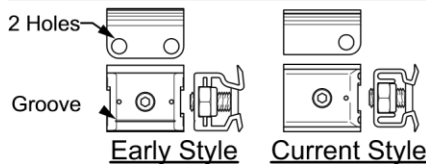
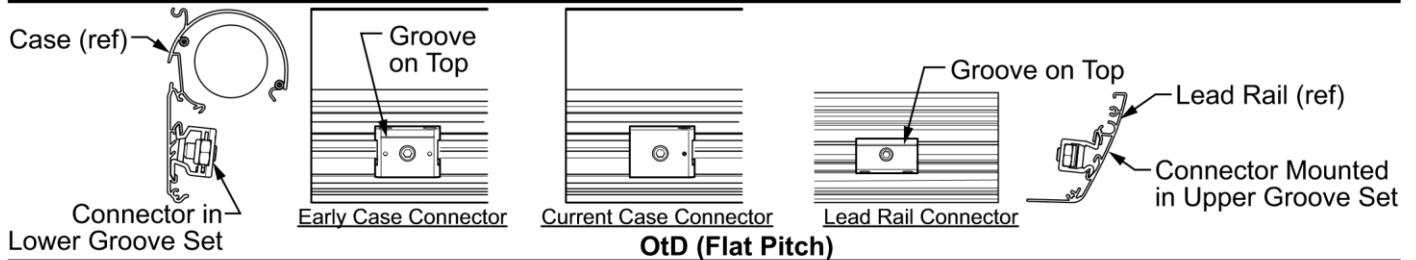
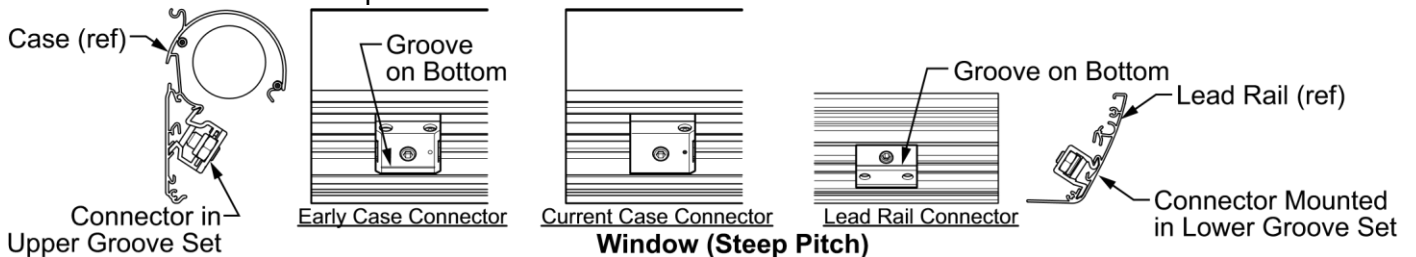

Two case connector configurations are used on the Marquee. The older style can be identified by the groove on the front face and the two holes through the top. The early and current connectors are not interchangeable.

Marquee011

REPLACING THE CASE CONNECTOR

1. Carefully mark the location of the existing connector in the case. Make note of the bracket orientation.
2. Remove the end cap. (Refer to details on page 2)
 - *For the idler side*, remove the screws and slide the end cap off of the roll bar idler and set aside. It will be necessary to support the roller tube.
 - *For the motor side*, remove the end cap screws and slide the end cap and motor out from the case and roller tube about 3"-4". It will be necessary to support and hold the roll bar when separating the motor. **NOTICE** When pulling the motor out of the case, the servicing technician must use care to not break or damage the motor cables.

When pulling the motor, do not let the roller tube come out more than 1"; otherwise the roller tube idler will disengage from the opposite end plate. If this occurs, reinsert the idler into the endplate before continuing.
3. Loosen the clamping screw on the connector and slide the old connector out of the case.

4. Insert the new connector assembly into the case and position at the marks made previously.
5. Tighten the clamping screw.
6. Reinstall the end plate. Ensure that the idler pin of the roll bar is properly seated. Ensure that the motor and crown are properly seated in the roller tube.
7. Reinstall the end caps.
8. Return to step 10 on the previous page.

MOTOR REPLACEMENT

This operation can be done while the awning is mounted on the RV. Use care to not damage the walls etc.

PRELIMINARY STEPS

1. Disconnect power to the awning.
2. If the awning is extended: (Refer to Detail A) Carefully push the lead rail toward the case so that the arms collapse. While holding the lead rail in this position, firmly tie the elbows of the spring arms together. Use a minimum 1/2" rope - do not use bungee cords.

When tying the rope, use a non-slip knot such as a square knot or equivalent.

3. If the awning is closed: Firmly brace the lead rail in the closed position. A second person can hold the lead rail steady during the disassembly process.



CAUTION Failure to secure the lead rail as described will allow the spring arms to unexpectedly extend out possibly causing personal injury and damage to the awning.

4. Determine the type of roller tube that is used on the unit. Examine the idler end cap. End caps without a removable plug uses a 2-slot roller tube, follow the procedure on page 6. End caps with the removable plug uses a 3-slot roller tube, follow the procedure on page 6.

Firmly Tie Elbows Together

MOTOR REPLACEMENT W/ 2-SLOT ROLLER TUBE (KIT NO. R001531)

1. Remove the four (4) screws holding the end cap to the case. Do not remove the two (2) motor screws.



CAUTION If the awning is closed when the end cap is detached, the spring arms will try to open. Continue to hold the lead rail closed.

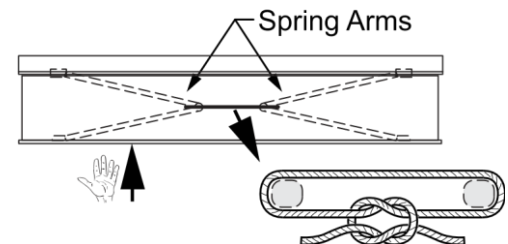

Marquee012

Figure 1. Tying the Arms.

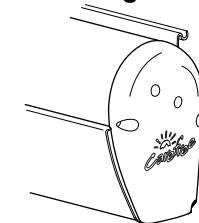

End Cap Without Removable Plug

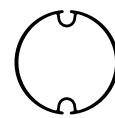

2-Slot Roller Tube

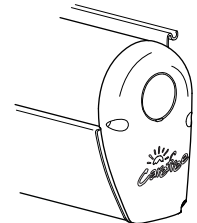

End Cap With Removable Plug



3-Slot Roller Tube

Marquee028

- Pull the end cap and motor partially out.

NOTICE When pulling the motor out of the roller tube, the servicing technician must use care to not break or damage the motor cables.

- Disconnect the motor wires from inside the vehicle and pull out or clip the motor wires. If cutting the motor wires be sure to leave enough wire that can be stripped and spliced.
- Pull the motor and end cap out of the roller tube.

CAUTION If the awning is closed

when the end cap is removed, the spring arms will try to open. Support the roller tube and allow the awning to open slowly then secure the arms as described previously.

- Remove the end cap and closeout from the old motor.

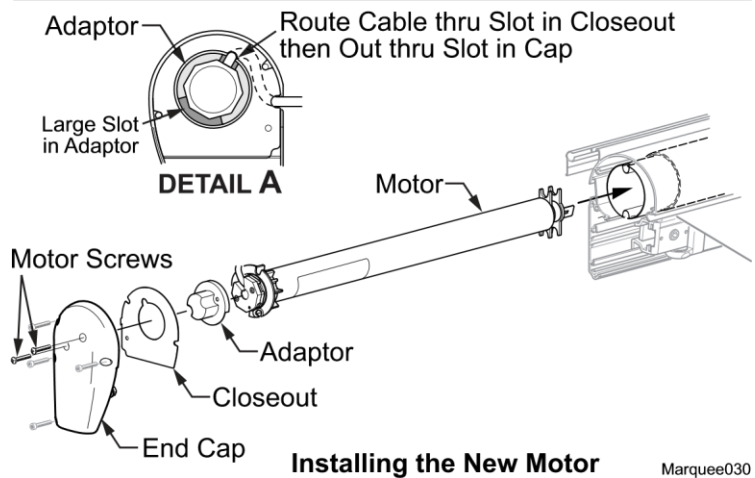
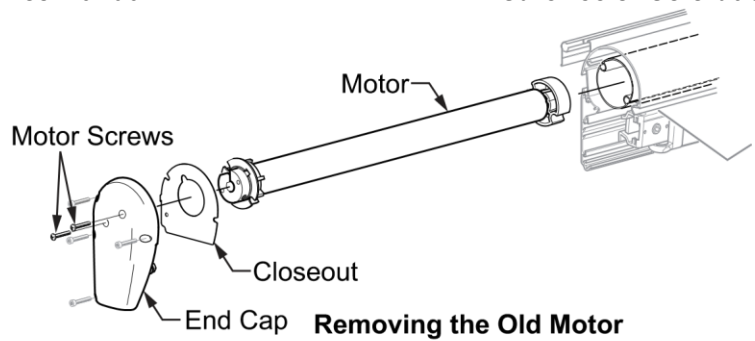

- Hold the closeout on the end cap and push the adaptor into the motor mount post in the end cap. Align the motor screw holes in the end cap, new adaptor and new motor. Attach the motor to the end cap using two (2) M4 x 25 screws. Note the orientation of the adaptor, motor and wire shown in Detail B.

IMPORTANT NOTE: On early units the motor was attached with M4 x 20mm screws; current production uses M4 x 25mm screws. When replacing a motor that is attached using the shorter screws, discard the existing screws and attach the motor using the longer screws and washers included with the motor replacement kit. Do not use the washers for units that already use the longer screws.

- (Detail A) Route the motor cable through the slot in the closeout then between the closeout and cap. Pull the cable out of the rear slot of the end cap.
 - Partially slide the new motor assembly into the roller tube. Ensure that the motor drive is properly seated inside the roller tube.
 - Route the new motor wire into the vehicle and attach or if the wires were cut, splice the new wires to the existing wires. Match the wires (Blue to Blue and Brown to Brown). Push the splices into the vehicle then use a quality silicone sealant to seal the wire hole into the vehicle.
- NOTE:** If splicing the wires, allow enough lead wire from the motor so that the completed splices can be pushed into the wall before sealing. There is not clearance room in the case for the wires and splices.
- Finish pressing the motor into the roller tube; make sure that the bearing is aligned with the roller tube. Attach the end cap to the case.
 - While holding the lead rail, carefully remove any roller tube supports and arm ties. Allow the lead rail to extend until the fabric is taut.
 - To test, restore power then extend and retract the awning.
 - After replacing the motor, it will be necessary to adjust the motor limits (page 8).

MOTOR REPLACEMENT W/ 3-SLOT ROLLER TUBE (KIT NO. R001651)



CAUTION

If the awning is closed when the end cap is removed, the spring arms will try to

open. Support the roller tube and allow the awning to open slowly then secure the arms by tying the elbows together as described above.

1. Remove the three (3) screws holding the end cap to the case. Remove the two (2) motor screws.
2. (Detail C) Carefully pull the end cap away from the case and remove the retaining ring and motor wire from the end cap. Set the end cap aside.
3. (Detail B) Remove the retaining screw from the bearing and roller tube. Pull the motor partially out from roller tube.

NOTICE When pulling the motor out, the servicing technician must use care to not break or damage the motor cables.

4. Disconnect the motor wires from inside the coach and pull out *or* clip the motor wires. If cutting the motor wires be sure to leave enough wire that can be stripped and spliced.

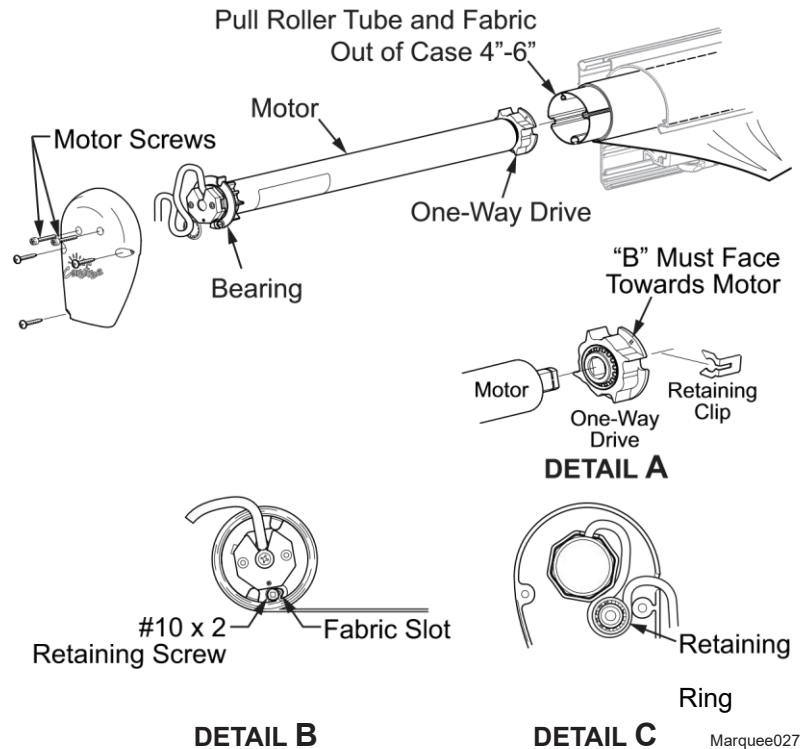

5. Pull the motor out of the roller tube and set aside.
6. (Detail A) On the new motor, check that the one-way drive is installed with the "B" facing the motor.

NOTICE The one-way drive must be oriented with the "B" facing the motor. If the drive is not oriented correctly, the awning will not operate and the arms will spring out when released.

7. (Detail B) Slide the new motor into the roller tube and attach the retaining screw through the bearing and in the fabric slot. The screw must be positioned to thread into the metal of the roller tube slot and the edge of the polycord. DO NOT OVER TIGHTEN, maximum torque 16 in-lbs.
8. Carefully pull the roller tube and fabric out of the case 4"-6". This will pull the roller tube out of the idler side.
9. Attach the end cap to the new motor. Note that the orientation is with the wire pointing up.
10. (Detail C) Route the wire in the end cap as shown. Secure using the retaining ring removed previously.
11. Route the new motor wire into the coach and attach or if the wires were cut, splice the new wires to the existing wires. Match the wires (Blue to Blue and Brown to Brown. Push the splices into the coach then use a quality silicone sealant to seal the wire hole into the coach.

NOTE: If splicing the wires, allow enough lead wire from the motor so that the completed splices can be pushed into the wall before sealing. There is no room in the case for the splices.

12. Align the roller tube on the idler side and slide the roller tube and fabric into the awning.

13. Align the screw holes in the end cap and attach to the awning case.
14. While holding the lead rail, carefully remove any roller tube supports and arm ties. Allow the lead rail to extend until the fabric is taut. If the lead rail continues to extend after the fabric is taut, the one way drive was installed backwards. Retie the arms, remove the motor and orient the one way drive as shown above.
15. To test, restore power then extend and retract the awning.
16. After replacing the motor, it will be necessary to adjust the motor limits (page 8).

SETTING THE MOTOR LIMITS

The limit switches are located inside the case, near the end cap. It is necessary to extend the awning to access the switches. The "OUT" limit switch stops the motor when the awning is fully extended. The "IN" limit switch stops the motor when the awning is fully retracted.

The limit switches are located inside the case. It is necessary to open the awning to access the switches.

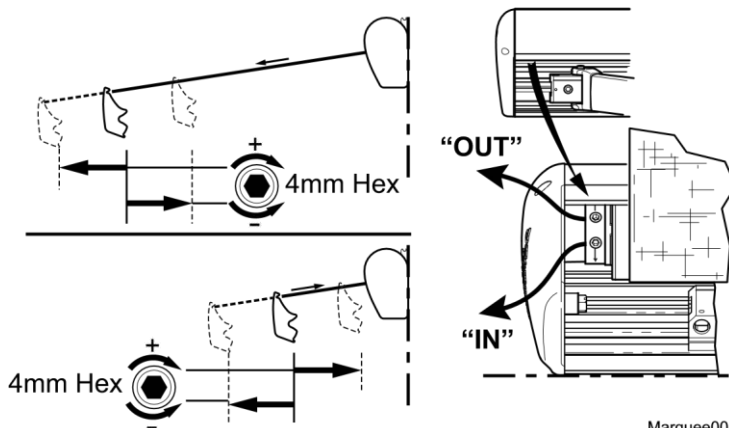

Marquee008

Out Limit Switch

1. Extend the awning out completely.
2. Confirm that the arms are fully extended. The motor should stop and the fabric should be tight. If the motor continues to run, the fabric will sag; or, if the motor quits before the arms are fully extended, it will be necessary to adjust the "OUT" limit switch.

NOTE: It is best to make the adjustments in increments of a single turn. 3 full turns of the screw equals approximately 2" of fabric extension.

3. If the fabric sags:
 - 3.1. Retract the awning until the fabric is tight then retract an addition 10"-12".
 - 3.2. Using a 4mm Allen wrench turn the "OUT" limit switch COUNTERCLOCKWISE to reduce the time the motor runs.
 - 3.3. Extend to confirm that the adjustment is correct.
 - 3.4. Repeat the procedure until the awning extends correctly.
4. If the arms do not extend completely:
 - 4.1. Retract the awning approximately 10"-12".
 - 4.2. Using a 4mm Allen wrench turn the "OUT" limit switch CLOCKWISE to increase the time the motor runs.
 - 4.3. Extend to confirm that the adjustment is correct.
 - 4.4. Repeat the procedure until the awning extends correctly.

IN Limit Switch

1. Retract the awning in completely.
2. Confirm that the arms are fully retracted. The motor should stop when the awning is fully retracted. If the motor quits before the arms are fully retracted; or, if the motor continues to run after the awning is closed, it will be necessary to adjust the "IN" limit switch.

NOTE: It is best to make the adjustments in increments of a single turn. 3 full turns of the screw equals approximately 2" of fabric extension.

3. If the motor stops before the awning is fully retracted:

- 3.1. Extend the awning 10"-12".
- 3.2. Turn the "IN" limit switch CLOCKWISE to increase the time the motor runs.
- 3.3. Retract the awning to confirm that the adjustment is correct.
- 3.4. Repeat the procedure until the awning retracts correctly.
4. If the motor continues to run:
 - 4.1. Extend the awning approximately 10"-12".
 - 4.2. Turn the "IN" limit switch COUNTERCLOCKWISE to decrease the time the motor runs.
 - 4.3. Extend and retract to confirm that the adjustment is correct.
 - 4.4. Repeat the procedure until the awning extends correctly.

WIRING DIAGRAMS

SWITCH INSTALLATION – NO RELAY

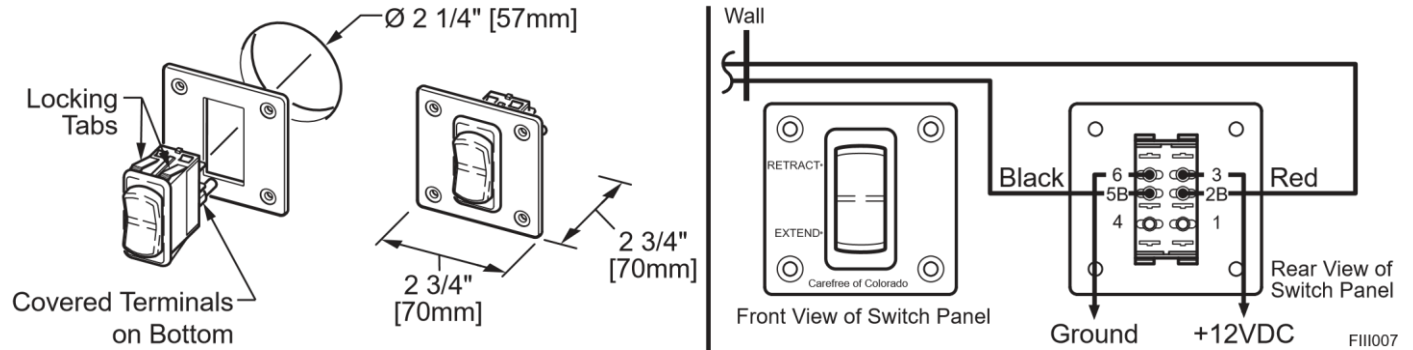

Through July, 2010

Switch hardware shown above has been discontinued. For wiring replacement switches, use instructions provided with the Single Switch Kit.

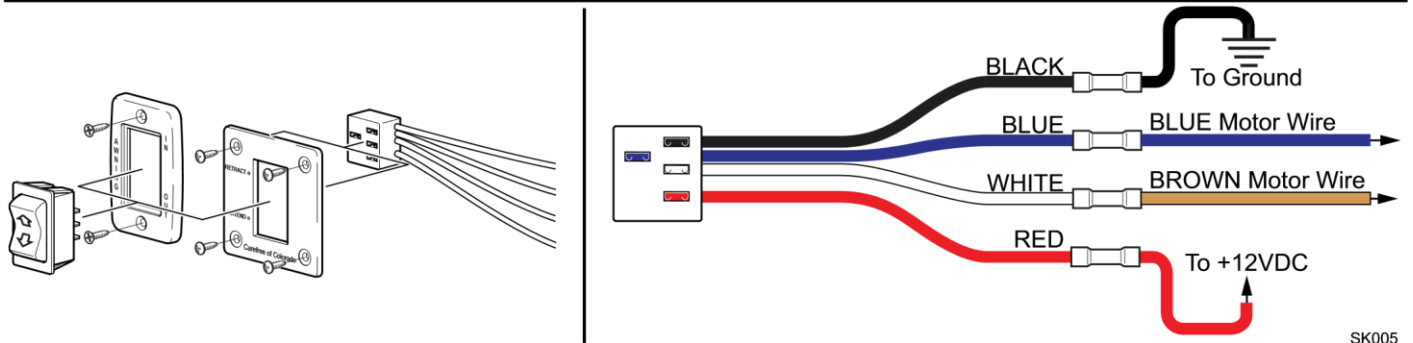

July, 2010 and On and Replacement Switches NOTES:

1. If connector block is oriented with wires to the left, reverse the motor wires. WHITE connector block wire goes to BLUE motor wire, BLUE connector wire goes to BROWN motor wire.
2. For first time replacement installation, refer to installation instructions furnished with replacement switch kit.

SWITCH INSTALLATION W/ RELAY MODULE

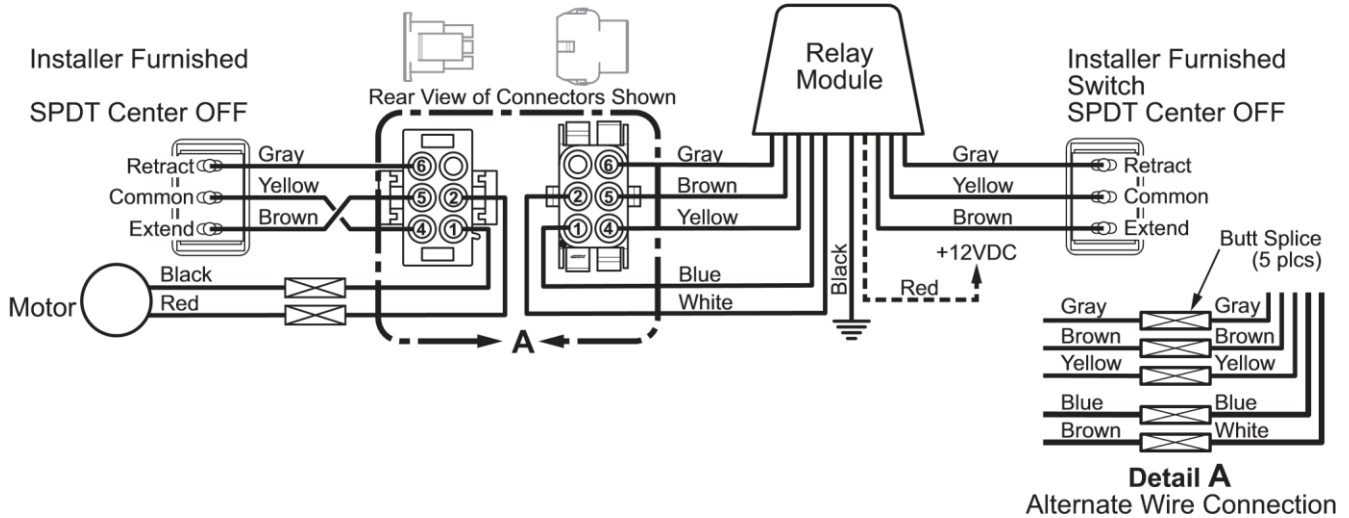

Switch

PV3007

The relay module allows installations to use up to two (2) single pole switches (not available from Carefree).

Switch characteristics: Single Pole, Double Throw (DPDT), Momentary ON, center OFF (Momentary ON – OFF – Momentary ON)

REMOVING THE AWNING

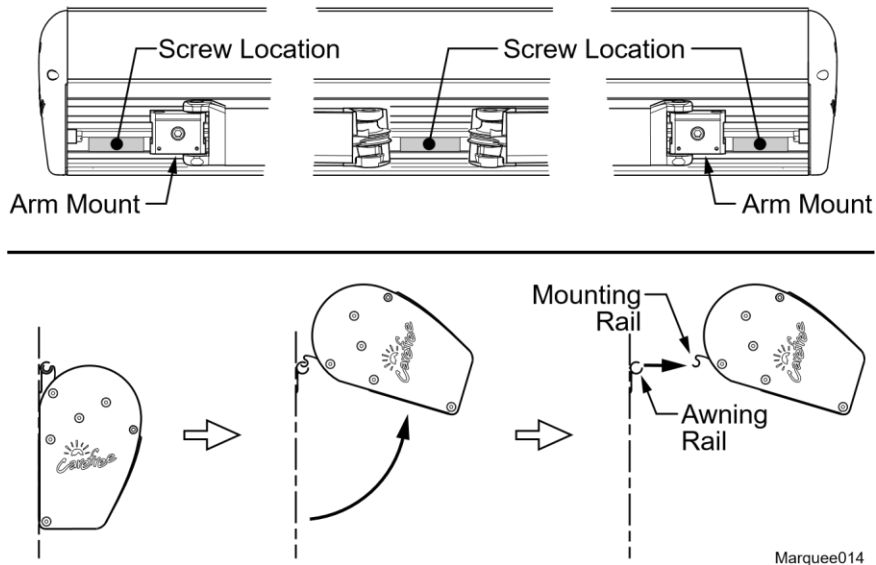

1. Open the awning
2. Remove the three screws that are through the bottom of the case.
3. Close the awning.
4. Disconnect power to the awning.
5. Disconnect the motor wires from the switch.
6. Rotate the awning upward in the awning rail.
7. Pull the wire out of the RV wall.
8. Using one person at each end of the awning, continue rotating the awning upward until the awning mounting rail slides out of the awning rail on the RV.

MANUAL OVERRIDE

For models built after July 2010, a manual override is available.

If power to the vehicle is not available, the awning can be safely retracted using the manual override located on the idler (right) end of the case.

NOTE: This procedure cannot be used to extend the awning.

1. Remove the plug from the right endcap and save.
2. Insert a 3/8" socket drive extension and handle into the square drive hole inside the endcap.
3. Turn the handle counterclockwise until the awning is retracted.

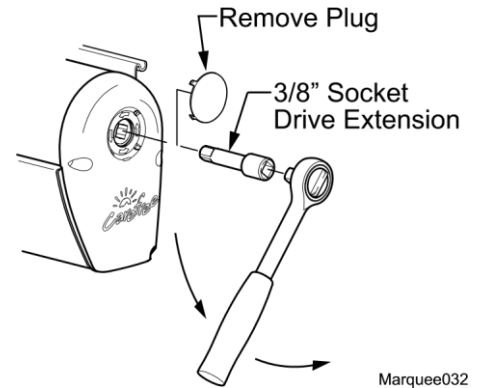

NOTICE After closing the awning with the manual override, the lead rail may move out from the case 1/4' – 1'2". This is normal and the awning is secure for travel until power is restored or repairs are completed. Do not attempt to force the lead rail in with the override, serious damage can occur to the awning.

STANDARD MAINTENANCE

Maintaining a Carefree Awning is easy. Just follow these basic steps:

- Always operate the awning according to the instructions.
- Periodically check that the fasteners are tight. Tighten if necessary.
- Keep the awning fabric and arms clean.

FABRIC CARE

NOTICE Do not use oil based cleaners or any caustic, granulated, or abrasive type cleaners on your Carefree product.

1. One of the best ways to keep the fabric looking good and to delay the need for deep or vigorous cleanings is to hose fabrics off on a monthly basis with clear water. This practice will help prevent dirt from becoming deeply imbedded in the fabric. In most environments, a thorough cleaning will be needed every two to three years.
2. When it's time for a thorough cleaning, the fabric can be cleaned while still on the awning frame. Use a stiff brush and warm water with soap.
3. When cleaning the fabric, it is important to observe the following:
 - Always use a natural soap, never detergent.
 - Water should be cold to lukewarm, never more than 100°F.
 - Air-dry only. Never apply heat to the fabric.
 - Always allow the fabric to dry thoroughly before rolling up the awning.

Mildew

Mildew is a fungus growth that looks like dirt. Vinyl coated polyester fabrics are mildew resistant because of a chemical biocide in the vinyl coating. Under ordinary conditions, mildew will not appear. However, in areas where high temperature and humidity are common, mildew can be a problem and required the material to be washed more frequently. Thoroughly rinse the fabric with clean water and allow to air dry completely before rolling up the awning.

Pooling

When water collects on the top of the fabric, this is known as "pooling". This can occur during inclement weather or if a running air conditioner discharges over the awning. The water is dumped when the awning is retracted. It is recommended that if water accumulates on the top; retract the awning in steps (8"-12") to dump the water. This will help prevent the fabric from stretching or distorting.

The effects of wind and rain on an awning are unpredictable. Severe damage to the awning and the vehicle may result. IF WIND OR EXTENDED PERIODS OF RAIN ARE EXPECTED, RETRACT THE AWNING.

ARM CARE

The best method of keeping the arms operating smoothly is to clean them.

Periodically wash out the channels with running water (i.e. a hose) to keep them clean. If the channels still do not slide easily, lightly spray the joints with a dry silicone lubricant, after the arms have been cleaned and dried thoroughly.

Hardware Maintenance

- Replace any parts that become damaged.
- Periodically check all mounting hardware, screws, lags, etc., and re-tighten when necessary.

MOTOR MAINTENANCE

- Check all wiring and connections for wear. Repair when needed.
- Check that the sealant is providing a good seal and no water is accumulating on the wiring.

PART NUMBER LISTING

PART NUMBER LOCATION

The part number/serial number is located on the inside of the lead rail.

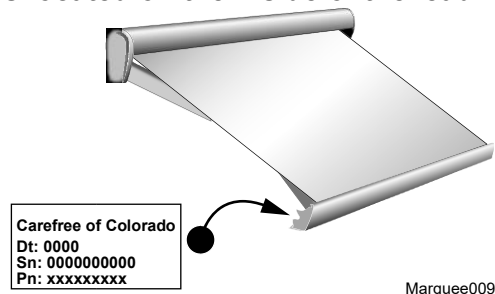

ILLUSTRATED PARTS LIST (UNITS BUILT PRIOR TO JULY 2010)

Use this page for units that do not have an end plug in the RH end cap. Use the next page if the unit has an end plug.

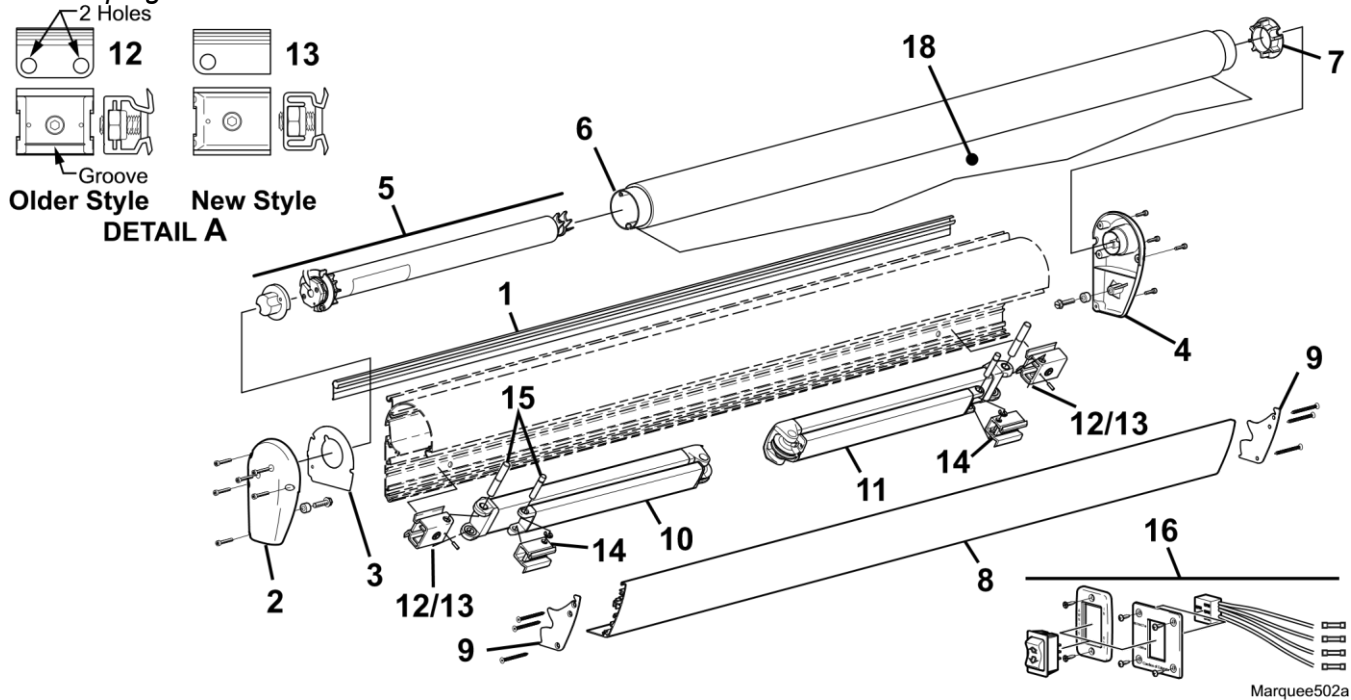

Marquee502a

ITEM	PART NUMBER	DESCRIPTION	NOTES
1	610700-xxxXXX	Awning Rail	See Hardware and Accessories
2	R037318-005	End Cap, White Only	LH 2
3	R054017-001	Wall, Closeout	
4	R037319-00X	End Cap	RH 2
5	R001531	Motor Kit	
6		Roller Tube	See Hardware and Accessories
7	R040751-001	Bearing, Roller Tube, RH	
8	R001781XXX-xxx	Lead Rail	7
9	R001725-00X	End Plate Kit	2,6
10	R012530-TB32L	Spring Arm Assy	LH 5
11	R012530-TB32R	Spring Arm Assy	RH 5
12	R019804-001	Connector Assy, Case	Window 3
	R019804-002	Connector Assy, Case	OtD 3
13	R019853-001	Connector Assy, Case	Window and OtD 3
14	R019799-001	Connector Assy, Lead Rail	
15	R001630	Hardware Pack, Arm Attach, 1 Arm	5
16	R001605	Switch Kit	
17	R019819-001	Owners Kit (manual & mounting screws)	
18		Canopy Only	Refer to Canopy Order Form

- Notes: 1. XXX = Color; xxx = Length in inches.
 2. 00X = 005 for White; 006 for Black
 3. Two case connector configurations are used on the Marquee (item 12 - original, item 13 - new). Refer to Detail A, older style can be identified by the groove on the front face and the two holes through the top. The new and old connectors are not interchangeable. Identify the correct connector before ordering.
 4. Motor kit (item 5) includes bearing, drive and end spacer.

5. Attaching hardware is not furnished with spring arm assemblies. Order item 16. Item 16 includes pins, set screw, retaining ring and bushings.
6. End plate kit (item 9) includes two end plates and hardware. End plates are universal and may be used on the left or right side.
7. Lead rail (item 8) includes end plate kit (item 9).

ILLUSTRATED PARTS LIST (UNITS BUILT AFTER TO JULY 2010)

Use this page for units that do have an end plug in the RH end cap. Use the previous page if the unit does not have an end plug.

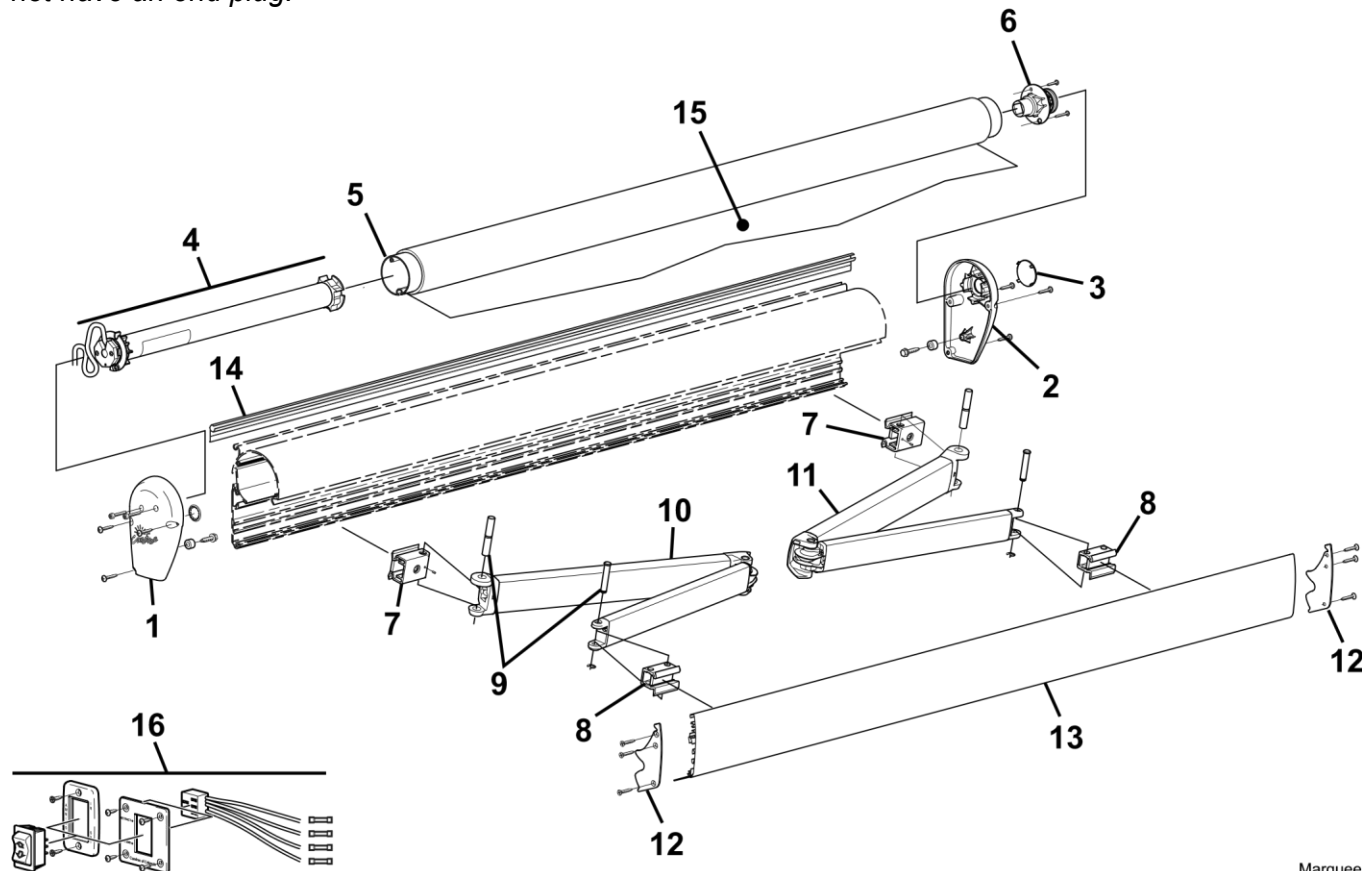

Marquee504

ITEM	PART NUMBER	DESCRIPTION	NOTES
1	R001660XXX	End Cap LH	
2	R001661XXX	End Cap RH	
3	R040792-00X	End Plug, Manual Override	
4	R001651	Motor Kit	2
5	610400-xxx	Roller Tube	
6	R001623	Roller Tube End Plug, RH	
7	R019853-001	Connector Assembly, Case	
8	R019799-001	Connector Assembly, Lead Rail	
9	R001630	Hardware Pack, Arm Attach, 1 Arm	
10	R012530-TB32L	Spring Arm Assembly, LH	3
11	R012530-TB32R	Spring Arm Assembly, RH	3
12	R001725-00X	End Plate Kit	2,5
13	R001362XXX-xxx	Lead Rail	6
14	610700-xxxXXX	Awning Rail	
15		Canopy Only	Refer to Canopy Order Form

Notes: 1. XXX = Color; xxx = Length. WHT= White; BLK = Black

2. 00X = 005 for White; 006 for Black

3. Motor Kit includes bearing and one-way drive.

4. Attaching hardware not included with spring arm assemblies. Order item 9. Item 9 includes pins, set screw and retaining ring.

5. End plate kit (item 12) includes two end plates and hardware. End plates are universal and may be used on the left or right side.

6. Lead rail (item 14) includes end plate kit (item 12).

For LED replacement parts and service procedures refer to 070013-301 “LED Service Manual for Box Awnings” available on-line at www.carefreeofcolorado.com