



**CAREFREE**

# SL WINDOW AWNING

Product style codes: IB, IF, IG, IK, IN, IP

Arm style codes: IC OR IA

## MANUAL PULL DOWN WINDOW AWNING

### RV



*Before operating the awning, carefully review the Owner's Manual. The manual contains important safety information, detailed operating instructions, common maintenance procedures and other useful information.*

## ***Installation and Operations Manual***

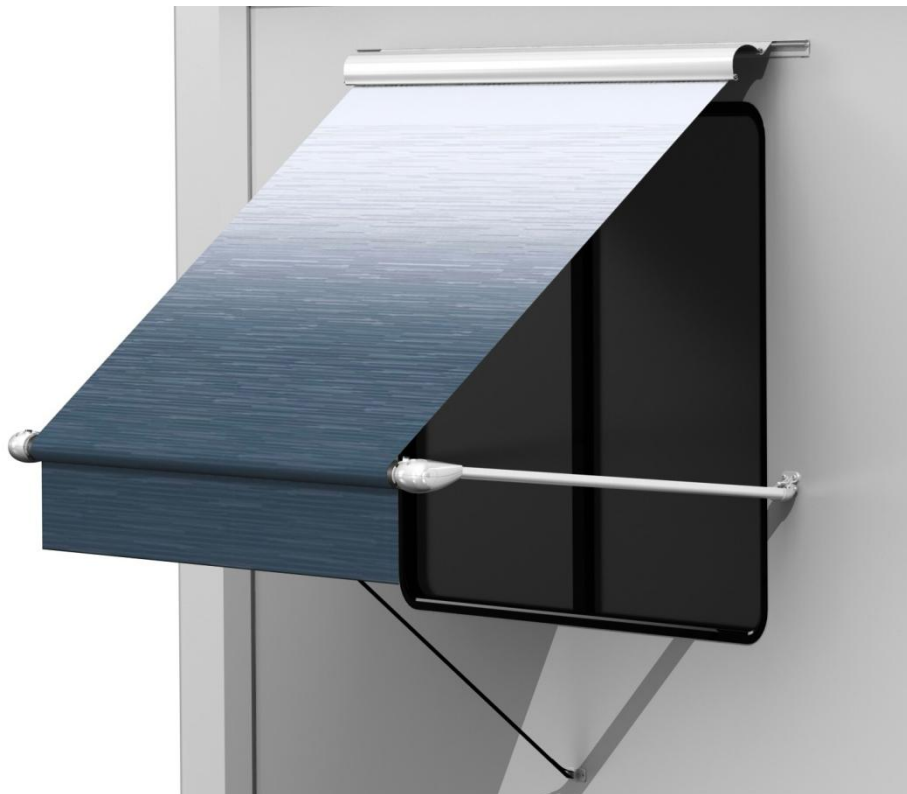

### **TABLE OF CONTENTS**

<b>Product Overview</b> .....	<b>1</b>
Component Checklist.....	1
<b>Installation</b> .....	<b>2</b>
Installing the Awning Rail.....	2
Installing the Awning.....	2
<b>Operation</b> .....	<b>4</b>
Cleaning .....	4
Mildew .....	4
Leaking.....	4
Arm Care .....	4
Hardware Maintenance.....	4

**Carefree Major Product Limited Warranty..... 5**



## PROPRIETARY STATEMENT

The SL Window Awning is a product of Carefree of Colorado, located in Broomfield, Colorado, USA. The information contained in or disclosed in this document is considered proprietary to Carefree of Colorado. Every effort has been made to ensure that the information presented in the document is accurate and complete. However, Carefree of Colorado assumes no liability for errors or for any damages that result from the use of this document.

The information contained in this manual pertains to the current configuration of the models listed on the title page. Earlier model configurations may differ from the information given. Carefree of Colorado reserves the right to cancel, change, alter or add any parts and assemblies, described in this manual, without prior notice.

Carefree of Colorado agrees to allow the reproduction of this document for use with Carefree of Colorado products only. Any other reproduction or translation of this document in whole or part is strictly prohibited without prior written approval from Carefree of Colorado.

## SAFETY INFORMATION



This is the safety alert symbol. It is used to alert individuals to potential personal injury hazards. Obey all safety messages that follow this symbol to avoid possible personal injury or death.



Indicates a hazardous situation, which if not avoided, could result in death or serious bodily injury.



Indicates a hazardous situation, which if not avoided, may result in minor or moderate bodily injury.



Indicates a situation that may result in equipment-related damage.

### General Safety:



This product can expose you to chemicals including Di-isodecyl phthalate (DIDP), Vinyl Chloride and Formaldehyde, which are known to the state of California to cause cancer or birth defects or other reproductive harm. For more information visit [www.P65warnings.ca.gov](http://www.P65warnings.ca.gov)



Shock Hazard. Always disconnect battery or power source before working on or around the electrical system.



Always wear appropriate safety equipment (i.e. goggles).



Always use appropriate lifting devices and/or helpers when lifting or holding heavy objects.



When using fasteners, do not over tighten. Soft materials such as fiberglass and aluminum can be "stripped out" and lose the ability to grip and hold.

## PRODUCT OVERVIEW

The SL Window awning is a manual extend/retract awning styled to match Carefree's Eclipse Patio Awning.

- Window awnings are available in 6 inch increments from 3 feet to 7 feet and in 12 inch increments from 7 feet to 15 feet.

Measure the width of the window, including the frame. Add 6" for mounting brackets. This is the minimum required width of the awning. Use the awning length one increment above the minimum required width.

*Example:* Window and frame measures 35" adding 6" equals 41". The correct awning width would be 42".

- Available in vinyl and acrylic fabrics.
- The optional Carefree Uniguard® metal wrap system is available to protect the awning from inclement weather conditions.

If Uniguard is installed, the awning requires 2.5" clearance below any projections above the window awning (i.e. window awning is mounted below a patio awning).

- An XL model is available for windows with 36" or more height.

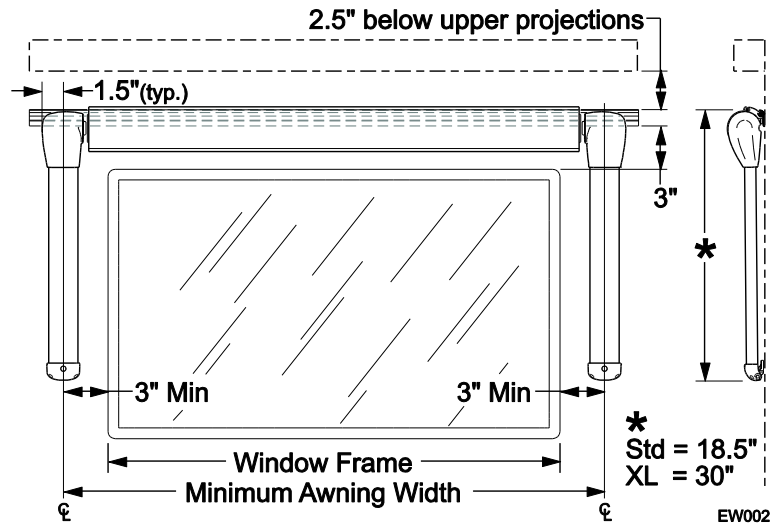

## COMPONENT CHECKLIST

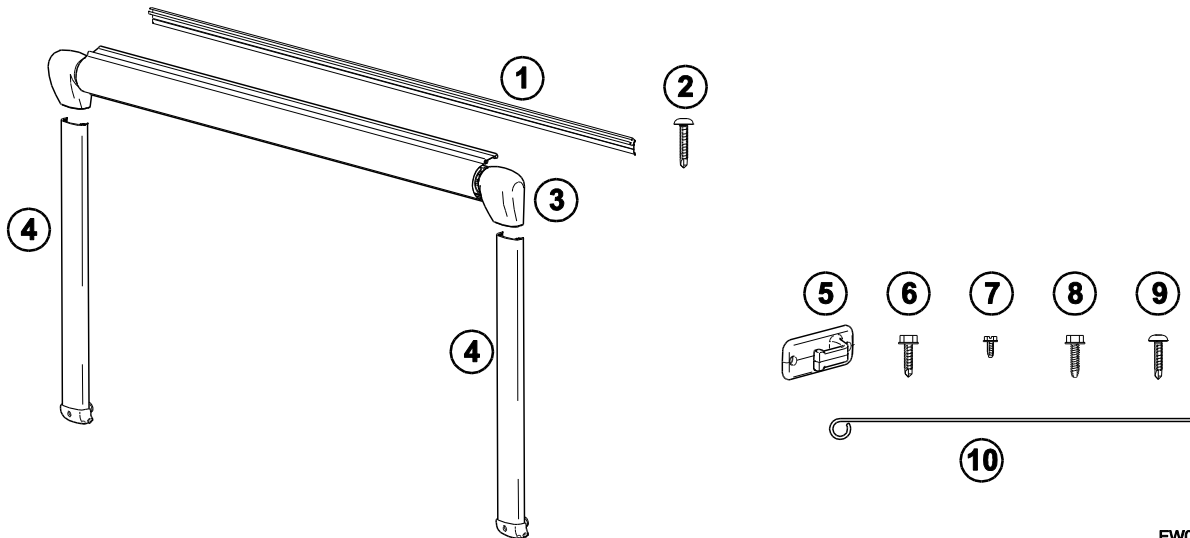

U	ITEM	DESCRIPTION		EW001 QTY	NOTE
<input type="checkbox"/>	1	Awning Rail		1	
<input type="checkbox"/>	2	Screw, Truss Head Square Drive, Awning Rail Attach	#10 x 1	NOTE	1
<input type="checkbox"/>	3	Roller Assembly		1	
<input type="checkbox"/>	4	Arm Assembly		2	
<input type="checkbox"/>	5	Pull Strap Catch		1	
<input type="checkbox"/>	6	Screw, Hex Washer Head	#10 x 3/4	2	
<input type="checkbox"/>	7	Screw, Hex Washer Head	#6 x 3/8	2	
<input type="checkbox"/>	8	Screw, Hex Washer Head, Stainless Steel	#10 x 3/4	2	
<input type="checkbox"/>	9	Screw, Truss Head Square Drive	#8 x 1	6	
<input type="checkbox"/>	10	Pull Cane	Ordered Separately	1	

**NOTE:** 1. Quantity for screw (item 2) depends on length of awning. Under 8' = 17; 8'-12' 11" = 38; 13' and longer = 50.

# INSTALLATION

## INSTALLING THE AWNING RAIL

Page 1 shows the general installation layout for the SL Window Awning.

1. Park the vehicle on a flat surface and level the unit.
2. Thoroughly clean the vehicle walls where the arms and awning rail are to be attached. Remove any old caulking or sealant.
3. Determine the optimum positioning of the awning so that the arms will not interfere with the window frame or light fixtures.
4. The bottom of the awning rail must be a minimum of 3 inches above the window frame.
5. The awning rail must be level.
6. After determining mounting position, mark the position with a chalk line.
7. Seal the back of the rail with silicone sealant or putty tape.
8. Align the awning rail onto the wall and secure with the supplied truss head #10 x 1" screws. The awning rail must be installed with the slot pointing up.

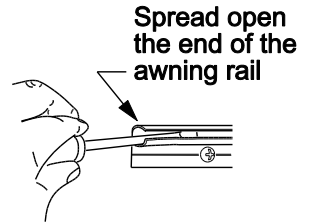
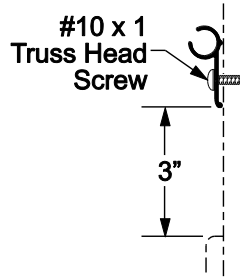

EW005

**NOTICE** Make sure the screws are securely mounted to the structural frame of the vehicle.

9. Use a screwdriver to spread open one end of the awning rail track on the installation side.
10. File any sharp edges or burrs from the end of the rail. This will help protect the awning fabric from damage during installation.
11. Spray inside the awning rail track with silicone lubricant.

## INSTALLING THE AWNING

### NOTES:

- The illustrations show the Uniguard. The instructions apply to awnings with or without Uniguard.
- Screws used to mount the components of the awning must go into structure. If there is no structure at the mounting location, drill a 7/32" hole through the skin and use 3/16" moly rivet (not included).

1. Assemble the arms and roll bar assembly.
  - Slide the arm into the end cap.
  - Secure using one #10 x 3/4 stainless steel screw through the back of the end cap.
  - Repeat for the other arm.

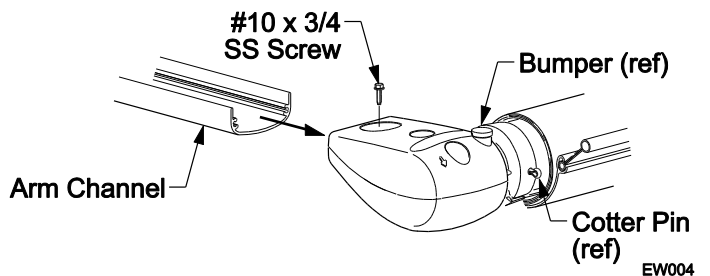

EW004

2. (refer to Detail A) With one person holding each arm, a third person should thread the polyrod (the plastic rod on the edge of the fabric) into the awning rail. Carefully move across the vehicle, gently pulling the fabric into the rail until the awning is centered over the window.

**NOTE:** While the awning fabric is fairly robust, exercise care to not snag it on the awning rail.

3. (refer to Detail B) Position the arms. The bumper pad on the back of the end caps must align and contact the flat portion of the awning rail and should be approximately 1/8" below the rail protrusion.

**NOTE:** If an awning rail screw interferes with the bumper, it will be necessary to remove the screw. The bumper must set flat on the flat portion of the awning rail.

*Tip: Make a temporary 1/8" shim to position the bumper during installation. (Refer to Detail B)*

4. (Refer to Detail C) Ensure that the arm is perpendicular to the awning rail. Secure the lower mounting bracket using one #8 x 1 truss head screw through the access hole in the end cap of the arm.
5. Repeat step 4 for the second arm. Make sure that the rollbar is parallel with the awning rail and that the arm is perpendicular to the awning rail.
6. Remove the spring locking pins from each end of the roll bar.

**NOTICE** Failure to remove the spring locking pins before attempting to open the awning can cause damage to the awning and/or coach.

7. Carefully open the awning by pulling down on the pull strap.
8. Horizontally position the pull strap on the rollbar.
9. (refer to Detail D) Insert the pull strap catch into the loop of the pullstrap.
10. Hold the awning arms with the valance pointing down from the bottom of the roller tube. While holding the pull strap taut and position the catch against the coach wall; then attach the catch using two (2) #10 x 3/4 screws.
11. (refer to Detail E) With the awning open, finish attaching the lower brackets. Secure using two (2) #10 x 1 truss head screws for each arm.
12. Open and close the awning several times. This is to center the awning in the awning rail.
13. (refer to Detail F) To secure the canopy, place a #6 x 3/8 screw through awning rail, polyrod and canopy approximately 1 inch from the end of the fabric.

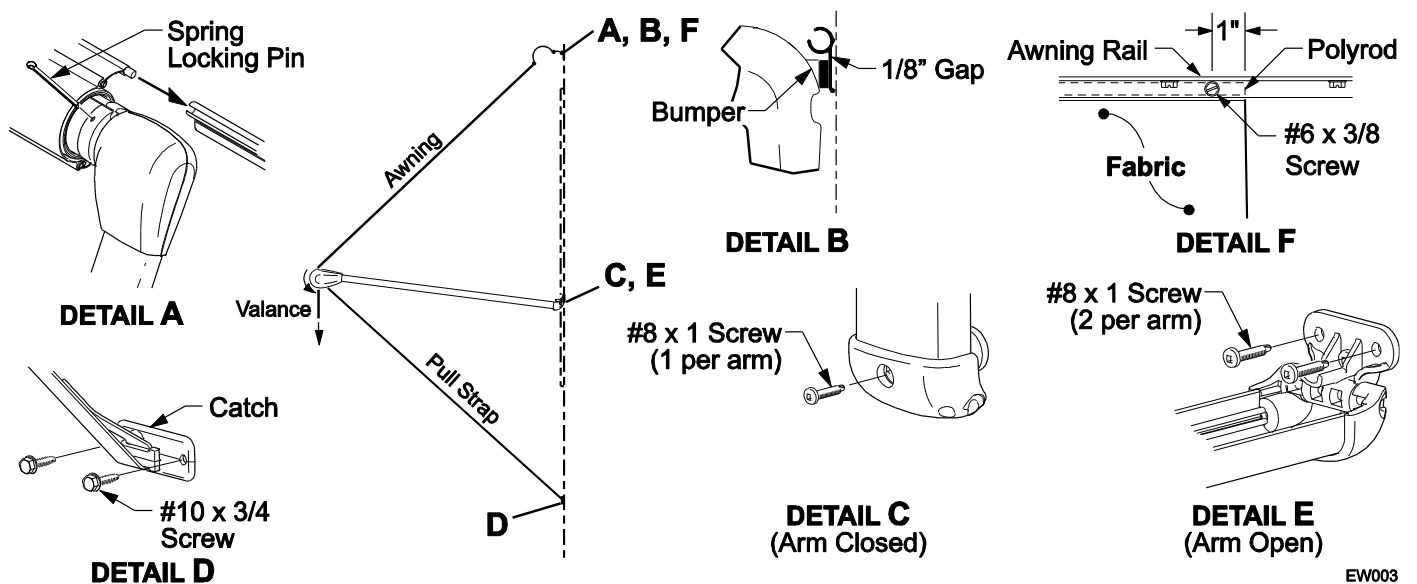

EW003

## OPERATION

*To Lower the Awning:* Using the pull cane, hook or grasp the pull strap and pull the awning down. Hook the loop of the pull strap onto the catch.

*Tip: During windy conditions, the strap may vibrate and "hum". To reduce this effect, twist the strap 1 turn before hooking onto the catch.*

*To Raise the Awning:* Remove the pull strap from the catch and untwist if necessary. Allow the awning to roll up while holding onto the strap.

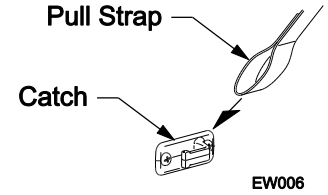

**CAUTION** Do not release the strap until the awning is against the coach wall. Releasing the strap early will cause the awning to slam against the wall causing damage to the awning and/or vehicle.

*Tip: When rolling up the awning, hold the end of the pull strap off center. This keeps the strap from rolling up on itself causing stretch marks in the fabric. This also reduces the amount of strap that hangs below the roller in the travel position.*

## CLEANING

**NOTICE** Do not use oil based cleaners or any caustic, granulated, or abrasive type cleaners on your Carefree product.

- One of the best ways to keep the fabric looking good and to delay the need for deep or vigorous cleanings is to hose fabrics off on a monthly basis with clear water. This practice will help prevent dirt from becoming deeply imbedded in the fabric. In most environments, a thorough cleaning will be needed every two to three years.
- When it's time for a thorough cleaning, the fabric can be cleaned while on the awning frame.
  - For Vinyl Fabric – Use a soft brush and warm water with soap.
  - For Acrylic Fabric – Use a stiff brush and warm water with soap.
- When cleaning the fabric, it is important to observe the following:
  - Always use a natural soap. Never detergent.
  - Water should be cold to lukewarm. Never more than 100 degrees.
  - Air-dry only. Never apply heat to the fabric.

### Mildew

Mildew is a fungus growth that looks like dirt. Vinyl coated polyester fabrics are mildew resistant because of a chemical biocide in the vinyl coating. Under ordinary conditions, mildew will not appear. However, in areas where high temperature and humidity are common, mildew can be a problem and require the material to be washed more frequently. THOROUGHLY rinse the fabric with clean water and allow to air dry completely before rolling up the awning.

### Leaking

On vinyl canopies, side hems and poly cords are stitched in with a sewing machine. On occasion, this stitching may allow water to seep or leak through the stitches. This is normal and not a defect covered by warranty. Treat the seams with a quality seam sealer.

## ARM CARE

The best method of keeping the arms operating smoothly is to clean them. Dirt and debris can cause the arms not to move easily. Periodically wash out the channels with running water (i.e. a hose) to keep them clean. If the arms still do not move easily, lightly spray the joints with a dry silicone lubricant after the arms have been cleaned and dried thoroughly.

### Hardware Maintenance

- Replace any parts that become damaged.
- Periodically check all mounting hardware, screws, lags, etc., and re-tighten when necessary.

## **CAREFREE MAJOR PRODUCT LIMITED WARRANTY**

Carefree of Colorado (hereafter referred to as Carefree) warrants to the first retail Purchaser that the Carefree Product is free of defects in material and workmanship within the terms and conditions as set forth in the warranty statement available online at [www.carefreeofcolorado.com](http://www.carefreeofcolorado.com). Carefree's obligation under this warranty is limited to the repair or replacement, at Carefree's option, of any defective component with new or factory refurbished components.

OWNER MUST RETAIN THE ORIGINAL PROOF OF PURCHASE AND/OR HAVE THE PRODUCT WARRANTY REGISTRATION ON FILE AT CAREFREE FOR WARRANTY CLAIMS.

THIS WARRANTY IS NOT TRANSFERABLE.

Visit [www.carefreeofcolorado.com](http://www.carefreeofcolorado.com) for

- Warranty Duration;
- Warranty Coverage and Exclusions;
- Warranty Terms of Coverage; and,
- Warranty Claim Procedures

*Register your Carefree products online at [www.carefreeofcolorado.com](http://www.carefreeofcolorado.com)*

**IMPORTANT NOTICE:** It is strongly recommended that adjustments and repairs not described in this book be performed by trained technicians at your Authorized Carefree Dealer. Work performed by non-authorized persons or businesses may void warranty.





