



Residential

THIS PUBLICATION COVERS THE FOLLOWING MODELS:

- Universal Sola
- Sola XL

TABLE OF CONTENTS

Introduction 2

Product Overview 2

 Sola Patio Awning Specifications: 2

 Sola Patio Awning Options: 2

Safety Information..... 2

 Safety Notes: 2

Components Checklist..... 3

Installation 4

Pre-Installation Layout and Preparation 4

 Installing the Awning Rail 5

 Awning Arm Mounting Surface 5

Assembling the Awning 6

Mounting the Awning 7

Wiring 8

Wiring Diagram 9

Final Assembly 10

Attaching the Fascia and Bottom Cover 10

Securing the Fabric..... 10

Removing the Temporary Assembly Pins..... 11

Installing the Alumaguard Tractioners 11

Operation 12

Switch Operation – Wall Mounted 12

Emergency Operation..... 12

Adjusting the Pitch..... 13

Rain Release Setting..... 13

Maintenance..... 14

Fabric Care 14

 Mildew 14

 Pooling 14

Arm Care 14

Motor Maintenance..... 14

Limited Warranty 15

INTRODUCTION

PRODUCT OVERVIEW

The Sola Patio Awning uses unique “scissor” style arms that do not require vertical ground support. The arms provide easy to use pitch adjustment—simply push together the pins on the arms, snap into the hole set desired, and the pitch is set! The pitch can be left in any position and the Sola will roll up completely! When the awning is rolled back out, it rolls out to pitch setting previously set.

The awning rollbar and arms are made from light weight, no-rust aluminum. The awning fabric is woven acrylic, one of the most durable, strongest, weather-resistant and fade resistant fabrics on the market.

Sola Patio Awning Specifications:

	SOLA UNIVERSAL	SOLA XL
<i>Maximum Extension:</i>	8 foot	9 foot
<i>Maximum Length:</i>	21 feet	21 feet
<i>Drop @ Min. Pitch:</i>	approximately 12 inches	approximately 13.5 inches
<i>Drop @ Max Pitch:</i>	approximately 40 inches	approximately 45 inches
<i>Extend Actuation:</i>	Gas Shock	Gas Shock
<i>Retract Actuation:</i>	Motorized roll up	Motorized roll up w/ supplemental spring tension
<i>Position Control:</i>	Motorized roll out/in	
<i>Power Requirements:</i>	12VDC (operating range 10VDC to 14VDC)	
<i>Circuit Rating:</i>	20 amp	
<i>Power Source:</i>	Power Converter	
	<i>Input:</i> 108VAC - 132VAC	<i>Input Watts:</i> 500 Watts
	<i>Output:</i> 13.4 VDC	<i>Output Amps:</i> 30 Amps
<i>Emergency Retract:</i>	Electrical override system (12VDC external power source)	

Sola Patio Awning Options:

- | | |
|---------------------------------------|--------------|
| • Alumaguard Awning Wrap ¹ | • SunBlocker |
|---------------------------------------|--------------|

NOTE:

1. Selected at time of initial order.

SAFETY INFORMATION

WARNING

A WARNING INDICATES A POTENTIALLY HAZARDOUS SITUATION THAT, IF NOT AVOIDED, COULD RESULT IN DEATH OR SERIOUS INJURY AND/OR MAJOR PROPERTY DAMAGE.

CAUTION

A CAUTION INDICATES A POTENTIALLY HAZARDOUS SITUATION THAT MAY CAUSE MINOR TO MODERATE PERSONAL INJURY AND/OR PROPERTY DAMAGE. IT MAY ALSO BE USED TO ALERT AGAINST UNSAFE PRACTICES.

NOTE: A note indicates further information about a product, part, or step.

Safety Notes:

- Always disconnect power source before working on or around the electrical system.
- Always wear appropriate safety equipment (i.e. goggles).
- Always use appropriate lifting devices and/or helpers when lifting or holding heavy objects.

CAUTION

IT IS RECOMMENDED THAT AT LEAST THREE PEOPLE INSTALL THE AWNING DUE TO ITS SIZE AND WEIGHT.

COMPONENTS CHECKLIST

Rollbar (ordered separately)

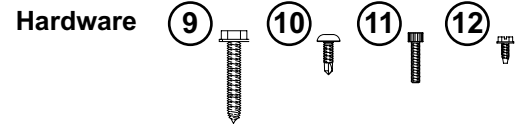
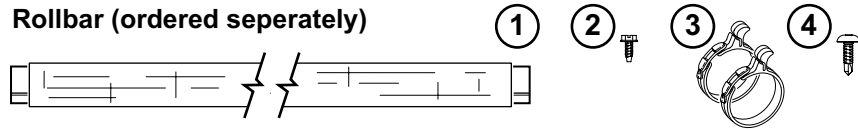

Arm Assemblies (see notes 1, 2)

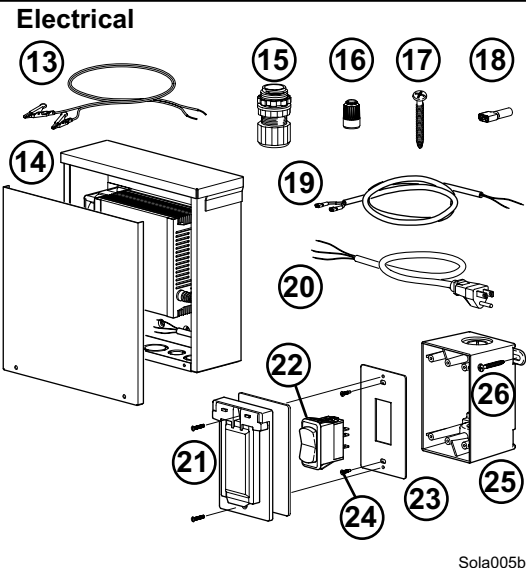
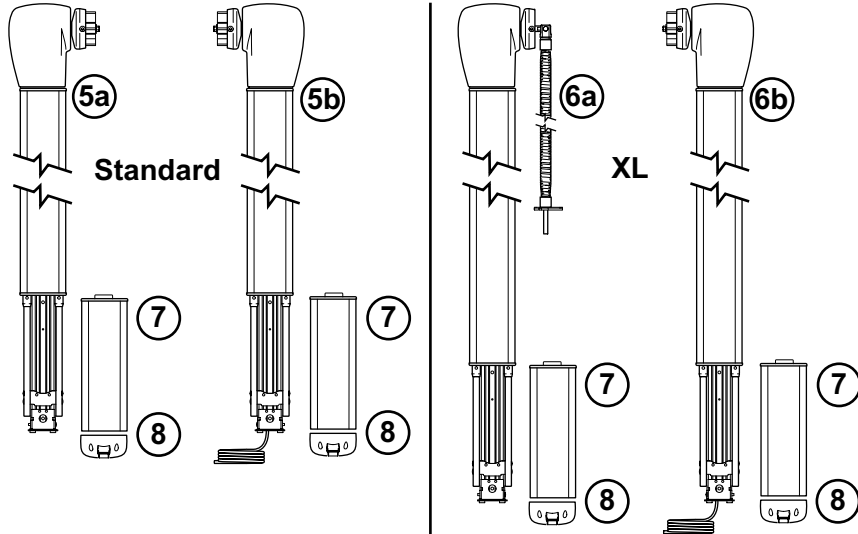

Sola005b

Figure 1. Component Checklist.

<input checked="" type="checkbox"/>	ITEM	DESCRIPTION	QTY	NOTE
<input type="checkbox"/>	1	Rollbar Assembly	1	
<input type="checkbox"/>	2	Screw, HWHC #6 x 3/8	2	
<input type="checkbox"/>	3	Tractioner	2	3
<input type="checkbox"/>	4	Screw, Truss Head, SQ Drive #10 x 5/8	2	3
<input type="checkbox"/>	5a	LH Arm Assy, Idler	1	2
<input type="checkbox"/>	5b	RH Arm Assy, Motorized	1	2
<input type="checkbox"/>	6a	LH Arm Assy, Idler, XL only	1	2
<input type="checkbox"/>	6b	RH Arm Assy, Motorized, XL only	1	2
<input type="checkbox"/>	7	Fascia Assy	2	
<input type="checkbox"/>	8	Bottom Cover w/o switch	2	
<input type="checkbox"/>	9	Screw, Lag 1/4 x 2 1/4	8	
<input type="checkbox"/>	10	Screw, Truss Head, SQ Drive #10 x 5/8	4	
<input type="checkbox"/>	11	Screw, SHC #8 x 3/4	4	
<input type="checkbox"/>	12	Screw, HWHC #6 x 3/8	2	
<input type="checkbox"/>	13	Jumper Cable	1	
<input type="checkbox"/>	14	Transformer w/ Junction Box	1	
<input type="checkbox"/>	15	Strain Relief Connector	4	
<input type="checkbox"/>	16	Wire Nut	3	
<input type="checkbox"/>	17	Screw, PPH 1/4 x 2 1/4	4	
<input type="checkbox"/>	18	Spade Connector, Female	2	
<input type="checkbox"/>	19	Jacketed Wire, 16/2 6 ft	1	
<input type="checkbox"/>	20	Plug and Wire 2 ft	1	
<input type="checkbox"/>	21	Switch Cover	1	
<input type="checkbox"/>	22	Switch	1	
<input type="checkbox"/>	23	Switch Plate, Mounting	1	
<input type="checkbox"/>	24	Screw #6-20 x 1/2	2	
<input type="checkbox"/>	25	Junction Box	1	
<input type="checkbox"/>	26	Screw, Lag #10 x 2	8	

- Notes:
- Awning configuration is specified at time of order, including awning length, fabric, color etc. Check awning assembly against original purchase order.
 - The arm assemblies are configuration specific and are not interchangeable.
 - Screws and Tractioners are furnished with rollbar assemblies equipped with optional Alumaguard.

INSTALLATION

PRE-INSTALLATION LAYOUT AND PREPARATION

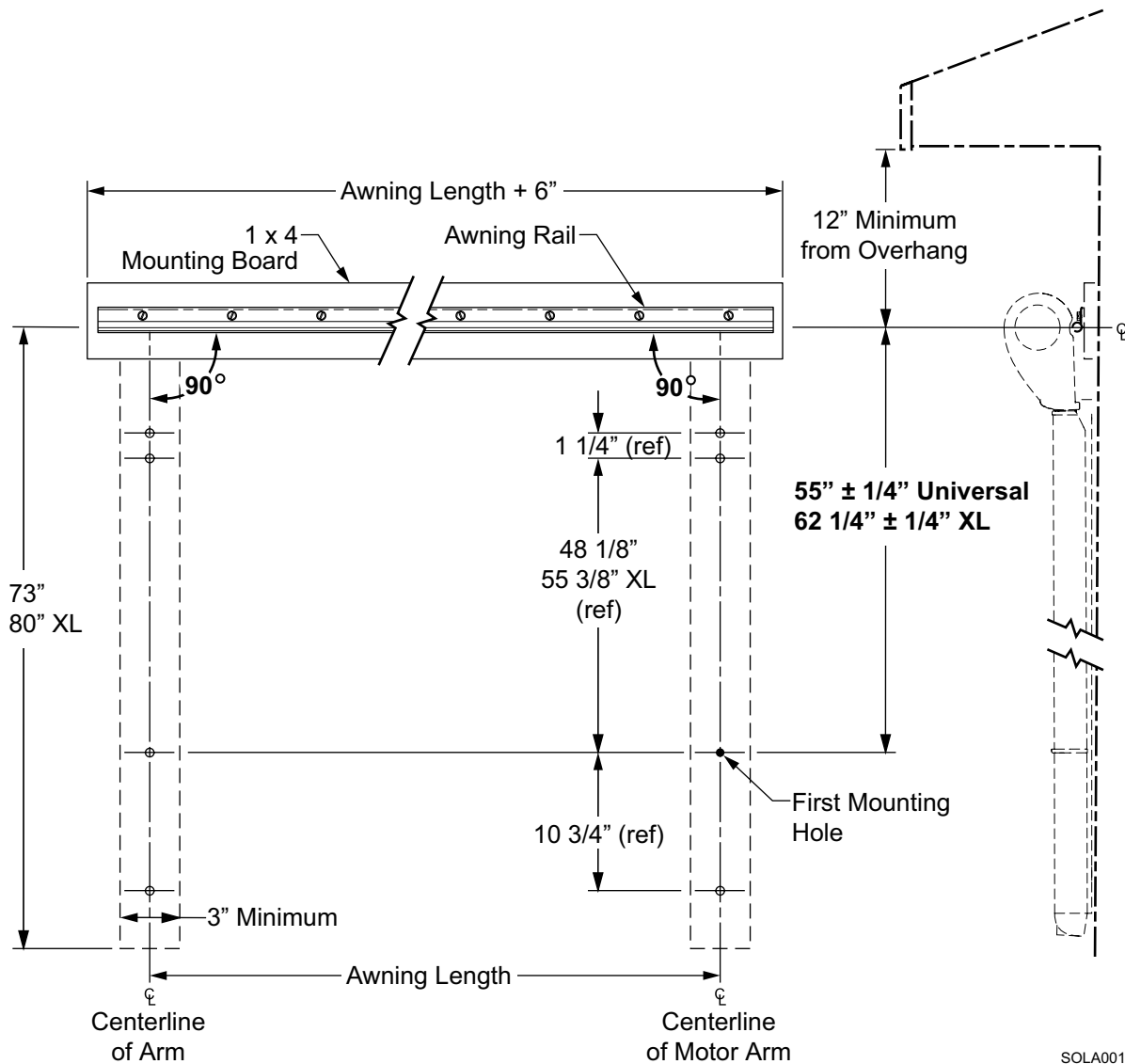

Figure 2. Installation Layout.

(Refer to Figure 2)

1. Determine the optimum position of the awning. The arms should not interfere with door frames, windows or light fixtures.
2. Determine the mounting locations of the power box and switch.
3. At the power box location, 110VAC input is required. The box may be wired with the furnished cord and plug that connects into a standard outdoor receptacle; or, power may be hardwired.
 - The installer must use a 110VAC circuit for the awning system that is protected by an appropriate sized circuit breaker. The awning draws a maximum of 3 amps.
 - For hardwire installations, the installer must install AC power in accordance with the prevailing building codes including required conduit, junction boxes etc. These items are not included in the awning kit and must be furnished by the installer.
4. Mark the centerline location of the awning rail. The centerline of the rail should be above the door opening a minimum of 6" for vinyl and 7" for Alumaguard. The awning rail must be level.

Installing the Awning Rail

(Refer to Figure 2)

1. If the mounting surface is solid wood, 1/2" thick or thicker, go to step 4. For all other surfaces, go to step 2.
2. Mount a standard 1" x 4" board centered in the location of the awning rail location. The board should be a minimum of 6" longer than the stated awning width. The board must be solidly anchored to the building structure (studs).
3. Paint or otherwise treat the mounting board to match the wall.
4. Mark the rail mounting position with a chalk line.
5. Seal the back of the rail with silicone sealant or putty tape.
6. Align the awning rail onto the wall and secure with #10 x 3/4" screws. Use all the attach holes in the rail.
7. (Refer to Figure 3) Use a screwdriver to spread open one end of the awning rail on the installation side.
8. File any sharp edges or burrs from the end of the rail. This will help protect the awning fabric from damage during installation.
9. Spray inside the awning rail track with silicone lubricant.

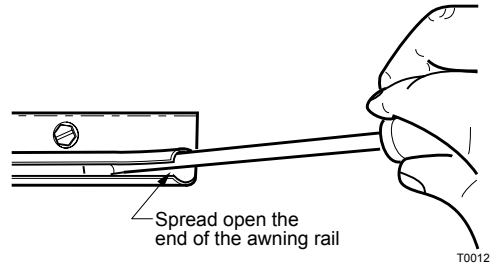

Figure 3. Adjusting the Awning Rail.

Awning Arm Mounting Surface

1. (refer to Figure 2) Prior to mounting the awning, inspect and clean the mounting area. The mounting area must be flat without ridges or irregularities. Smooth the area as required.
2. Determine the best method to attach the arms to the wall.
 - The arms must attach to the structure of the building or to reinforced support members that are attached to the structure.
 - When attaching the arms, DO NOT over tighten the screws. Over tightening can cause the screws to warp or otherwise distort the channels, possibly causing the arms to not operate correctly.

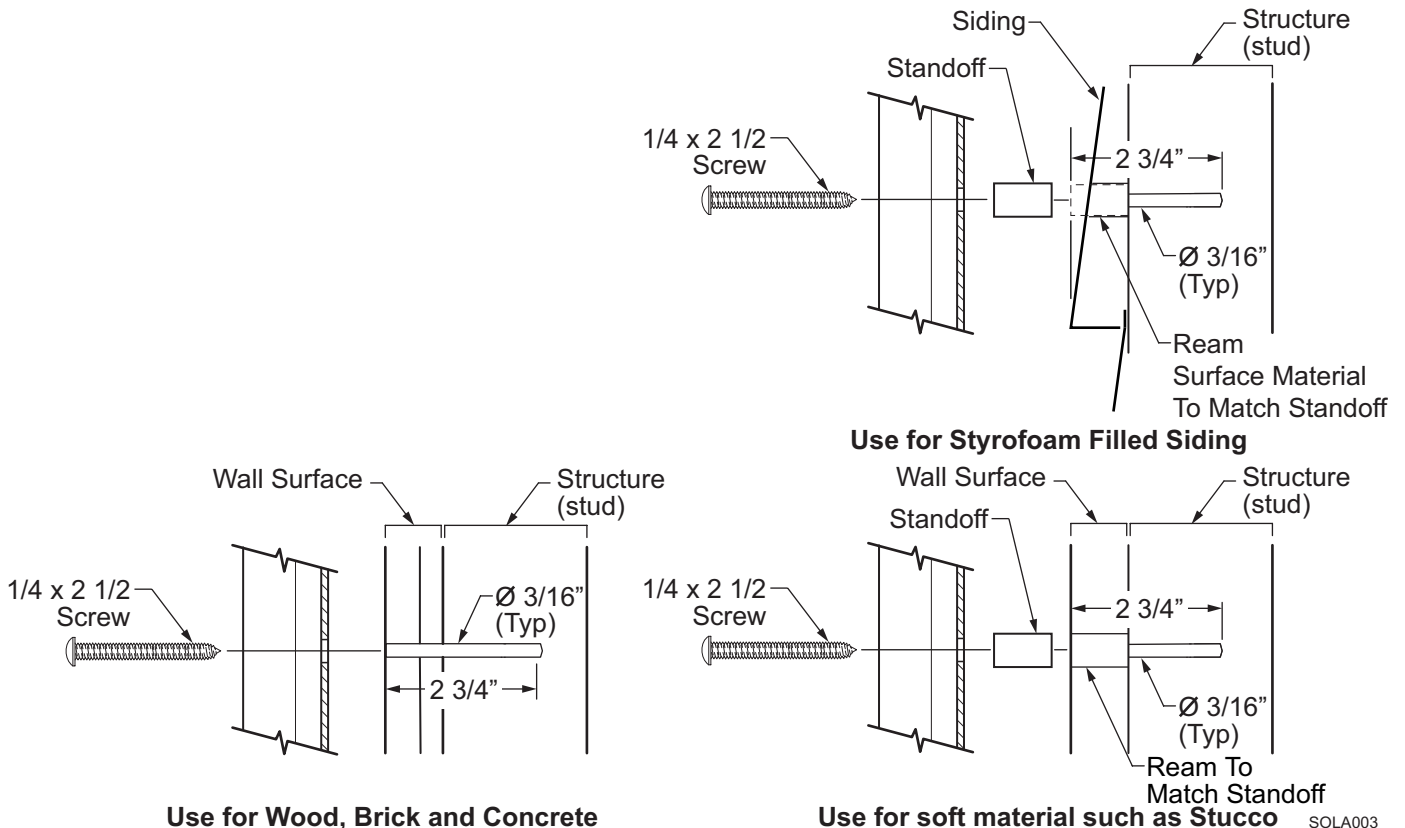

Figure 4. Attaching the Arms.

ASSEMBLING THE AWNING

1. Determine the location of the power box in relation to the motorized arm.
2. If the motor cable is to be routed at the bottom of the arm, no modification is required. Go to step 4.
3. If the motor cable is to be routed at the top of the arm:
 - 3.1 Remove the plastic wrap at the top of the motorized arm. Partially open the arm being careful to not let the arm extend more than 6".

CAUTION

THE ARM IS UNDER TENSION FROM THE GAS SHOCK LOCATED IN THE ARM.

- 3.2 (Refer to Figure 5) Pull the motor cable out of the hole in the top of the channel.
- 3.3 Route the excess wire up and out the top of the channel and close the arm.
- 3.4 Secure the top of the arm in the closed position using a plastic wrap or equivalent.

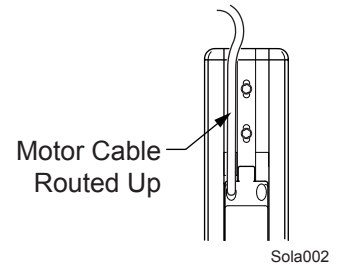

Figure 5. Routing Cable Up.

CAUTION

DURING ASSEMBLY AND INSTALLATION, THE ARM ASSEMBLIES MUST REMAIN PERPENDICULAR TO THE ROLLER ASSEMBLY. FAILURE TO HANDLE THE ARM ASSEMBLIES CAREFULLY CAN BEND THE DRIVE SHAFT.

4. (Refer to Figure 6) Align the roller assembly with the coupler on the motorized arm assembly. Partially insert the coupler into the roller assembly.

NOTE: The roller assembly must be oriented with the fabric going over the roller.

5. Rotate the end cap until the slot in the cap aligns with the empty slot in the roller assembly, then finish pressing the roller assembly fully onto the coupler and into the cap.

NOTE: The end cap must seat squarely over the end of the roller assembly when complete.

6. Secure the end cap to the roller assembly using two #10 square-drive screws.
7. For the universal awning, repeat steps 4 through 6 to attach the non-motorized arm assembly to the roller assembly.
8. For the XL awning, insert the spring into the roller assembly then rotate the end cap until the slot in the cap aligns with the empty slot in the roller assembly. Finish pressing the roller assembly fully into the cap and secure using two # 10 square drive screws.

CAUTION

NO PRE-TENSION IS REQUIRED ON THE SPRING. Do not WIND OR TWIST THE SPRING.

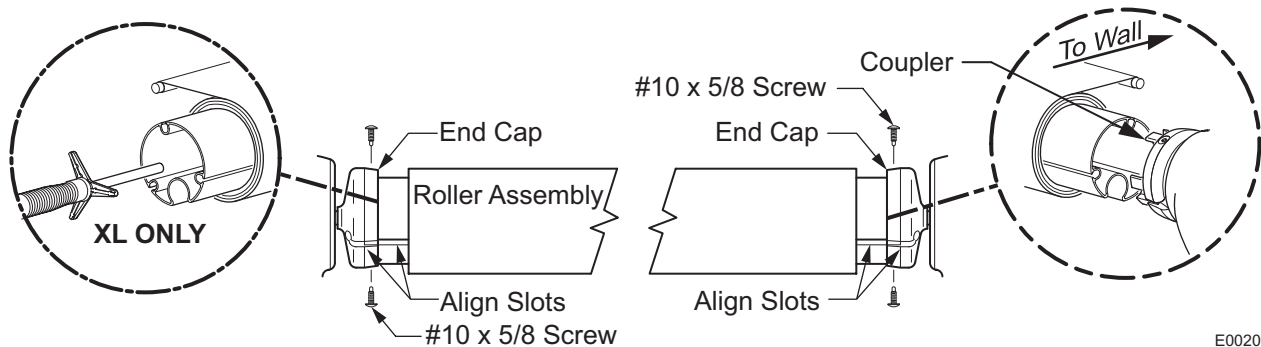

Figure 6. Assembling the Awning.

MOUNTING THE AWNING

(Refer to Figure 2 on page 4)

1. Prepare the mounting surface as required. (Refer to "Awning Arm Mounting Surface" on page 5)
2. On the awning rail, mark the location of the centerline of the motorized arm assembly. From that mark, measure down vertically a distance of 55 7/8 inches (63 1/8" for XL model) from the centerline of the awning rail to the first mounting hole. This will be the initial mounting hole.
3. From the mark in step 1, mark the remaining 3 mounting holes. Ensure that the center lines of the holes are in line and perpendicular to the awning rail.
4. Drill four (4) 3/16" pilot holes at the marks made above.
5. Unroll the canopy one wrap.
6. With one person holding each arm, the third person should thread the polyrod (the plastic rod on the edge of the fabric) into the awning rail, starting at one end. Carefully move across the wall, gently pulling the fabric into the rail, until the awning is in the pre-determined location.

NOTE: While the awning fabric is fairly robust, use care to not snag on the awning rail.

7. Position first mounting hole of the motorized arm with the pre drilled hole.
8. Temporarily attach the arm using a 1/4" lag screw
9. Confirm that the arm is perpendicular to the awning rail.
10. Position the roller assembly so that it is perpendicular to the motorized arm assembly. Position the non-motorized arm perpendicular to the roller assembly.

IMPORTANT NOTE: For Alumaguard installations, the centerline of the roll bar must be 3/4" ± 1/4" above the centerline of the awning rail.

11. Mark the location of the exposed attachment holes for the non-motorized arm.
12. Remove the temporary screw from the motorized arm and carefully slide the arms and canopy to the side to access the marks made in step 11.
13. From the mark in step 12, mark the remaining 3 mounting holes. Ensure that the center lines of the holes are in line and perpendicular to the awning rail.
14. Drill four 3/16" pilot holes at the marks from step 13.
15. Move the arms and fabric to align the mounting holes with the pilot holes.
16. In the bottom two mounting holes, attach the motorized arm with two (2) 1/4 x 2 1/2 lag screws.
17. Repeat for the non-motorized arm.
18. Hold the awning closed and carefully remove the plastic wraps at the top of the arms. The awning will open a few inches.
19. Open the awning about 18" or until top mounting holes on the arms are exposed.
 - To open, use a 9V-18V power source, such as a cordless drill battery.
 - Touch the motor wires to the battery terminals.
 - Maintain contact until the awning is extended about 18".
 - If the awning does not begin to move, reverse the wires on the battery terminals.
20. Using two each 1/4 x 2-1/2" lag screws, attach the top of the arm assemblies.

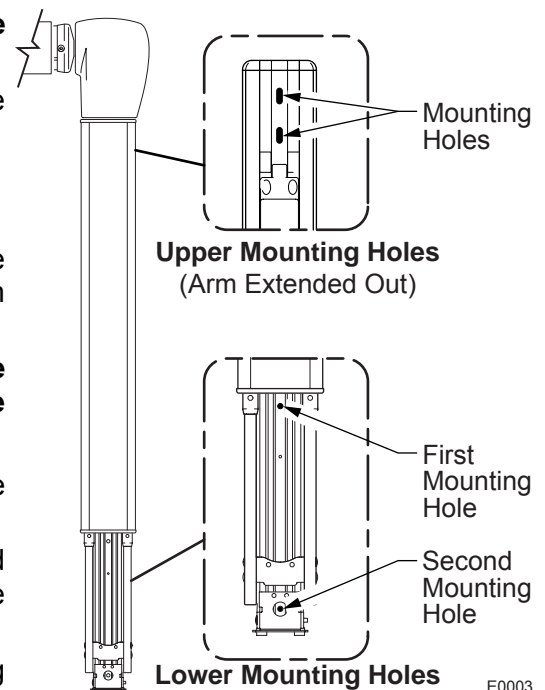

Figure 7. Arm Mounting Hole Locations.

WIRING

NOTES:

- Failure to follow the wiring instructions in this publication may void the motor warranty.
- Do NOT wire two or more motors to one switch—No parallel wiring.
- Any deviations in wiring to/from the 110VAC power source must be done by a certified electrician.
- All wiring must conform to NEC (National Electrical Code) and the prevailing building codes.

⚠ CAUTION

ALWAYS DISCONNECT THE ELECTRICAL SOURCES BEFORE WORKING WITH THE ELECTRICAL WIRING.

1. Determine the final location of the switch and the control box and mark the locations.

NOTE: With the supplied cables, the converter box must be located within 18 inches of the exterior receptacle. The switch box must be located within 3 feet of the awning arm and within 6 feet of the converter box.

2. Mount the converter box using 4 1/4 x 2 1/2 screws. The box has an appreciable weight and must be firmly secured to the structure.
3. Attach the strain relief connectors to the converter box.
4. Attach the strain relief connector and plugs into the switch outlet box.
5. Mount the switch outlet box. The mounting tabs may be positioned on the box for best fit.

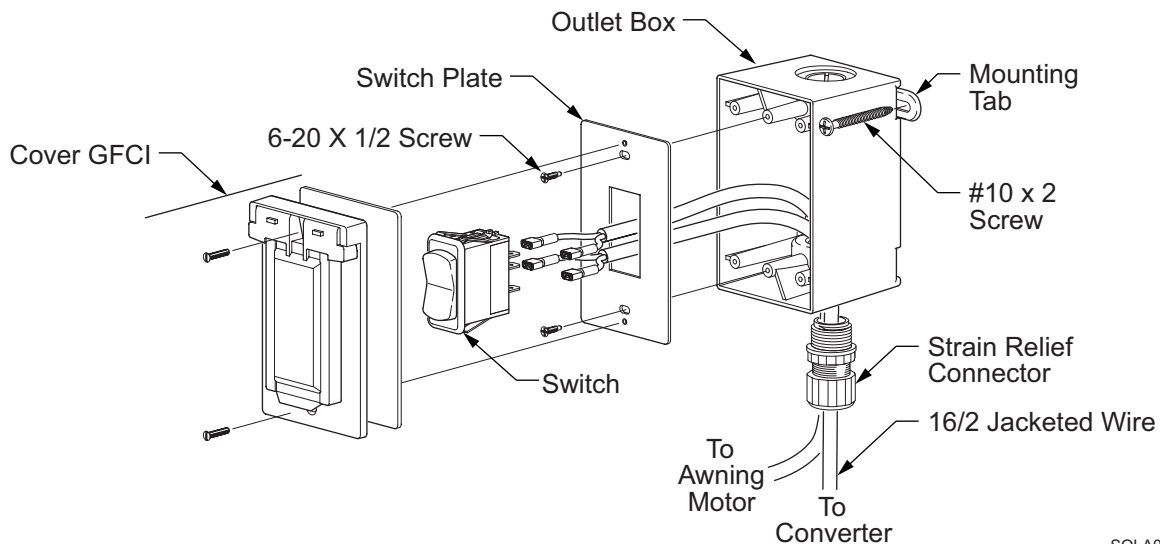

SOLA004

Figure 8. Switch Mounting.

6. Route the motor wire, from the awning, through the strain relief connector, outlet box and switch plate.
7. Terminate the wires with the included female spade connectors and attach to the switch. Red goes to pin 2B, Black goes to pin 5B.
8. Attach the 2-wire cable to the switch. Red goes to Pin1, Black goes to Pin 4.
9. Route the cable through the switch plate, outlet box and strain relief connector.
10. Push the switch into the switch plate until the locking tabs click into place behind the switch plate.
11. Attach the switch plate to the outlet box using the #6 x 20 screws.
12. Push out the center shape in the gasket. Attach the cover and gasket to the outlet box with the supplied screws.
13. Tighten the strain relief connector.

14. Route the cable from step 8 and 9 to the converter box.
15. (refer to Figure 9) Attach the Red wire to the "POS" terminal and the Black wire to the "NEG" terminal.
16. Route the plug cable through the strain relief connector to the converter.
17. Using the supplied wire nuts attach the wires to the converter. Be sure to match the wire colors; white to white (neutral), black to black (line) and green to green (ground).
18. Tighten the strain relief connectors.
19. Plug the unit into an outlet.
20. Press the switch down, the awning should extend. Press the switch up, the awning should retract.
21. If the awning operates in reverse; disconnect power and reverse the Red and Black wires at the NEG and POS terminals of the converter.
22. Close and secure the box lid.

WIRING DIAGRAM

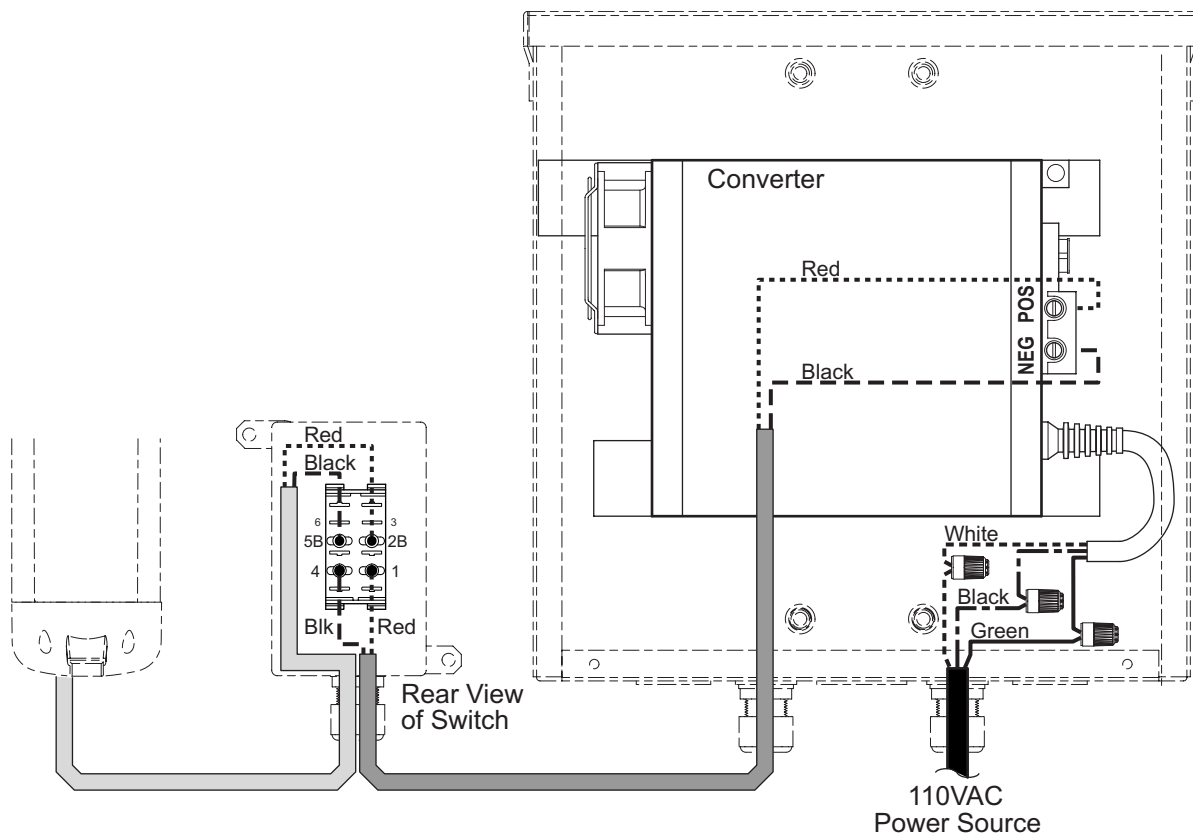

SOLA006

Figure 9. Wiring Diagram.

FINAL ASSEMBLY

ATTACHING THE FASCIA AND BOTTOM COVER

For installations not using the exterior switch: Before continuing, remove the switch and cable from the RH end cover and discard. Snap the furnished plug into the hole in the cover.

1. Make sure the awning is completely closed.
2. Insert the tab, on the fascia, under the arm base and rest it on the mounting plate.
3. Check that the gap between the top of the fascia and the arm channel is approximately 1/8".
 - a. If the gap is too large or too small, set the fascia aside, loosen the mounting plate screws and adjust the mounting plate height as required. Tighten the screws and set the fascia in position.
4. Place the bottom cover beneath fascia. Carefully tuck any wires into the bottom cover.

NOTE: There are tabs on the top of the cover to correctly align the bottom cover and fascia. The fascia should seat in the groove of the cover.

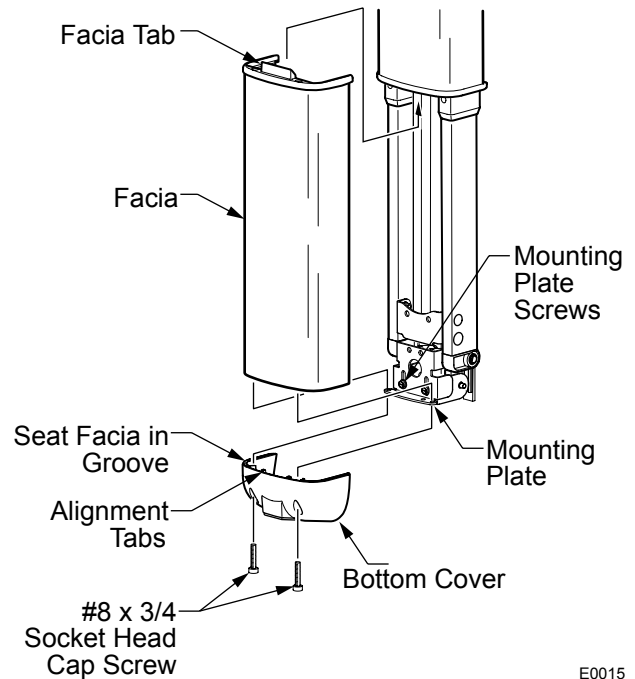

E0015

Figure 10. Attaching the Fascia and Bottom Cover.

5. Attach the cover to the fascia with the supplied socket head screws using a 9/64" Allen wrench. The bolts must go through the cover, the plate, and the fascia.
6. Repeat for the other side.
7. Verify proper installation by opening and closing the awning.

SECURING THE FABRIC

1. Roll the awning in and out several times to make sure that the fabric is square on the rollbar.
2. (Refer to Figure 11) Secure the canopy fabric or Alumaguard using one, #6 x 3/8" hex head screw at both sides of the awning.

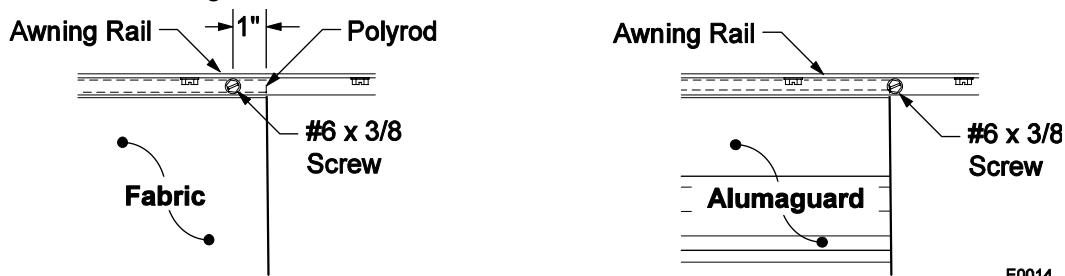

E0014

Figure 11. Securing the Fabric.

- 2.1 For vinyl (non Alumaguard) awnings, place screw through awning rail, polyrod and canopy approximately 1" in from the end of the fabric.
- 2.2 For Alumaguard awnings, place screw on the outer edge of the Alumaguard (not through the Alumaguard).

REMOVING THE TEMPORARY ASSEMBLY PINS

2 pins are inserted into the back of the left (idler) head for lateral stability during installation. Using a pair of pliers, remove and discard both pins.

NOTE: The awning will operate with the pins in place; for long term use, the pins must be removed.

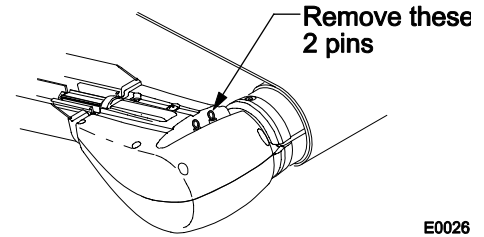

E0026

Figure 12. Removing the Assembly Pins.

INSTALLING THE ALUMAGUARD TRACTIONERS

This is only required when the optional Alumaguard metal wrap shield is installed.

(Refer to Figure 13)

1. Partially extend the awning until the Alumaguard is extended as shown.
2. Unlock the keeper and wrap the tractioner around the roller tube.
3. Position the tractioner under the Alumaguard with a 1/4" gap between Alumaguard and tractioner. Lock the keeper.
4. Repeat for the other end of the rollbar.
5. Extend the awning to verify that the Alumaguard tractioners are lifting the Alumaguard up and over the roller assembly.
6. To secure the tractioner, drill a 1/8" hole through the tractioner and rollbar, roughly center the hole between two slots of the rollbar.
7. Secure with one (1) #10 square drive screw.

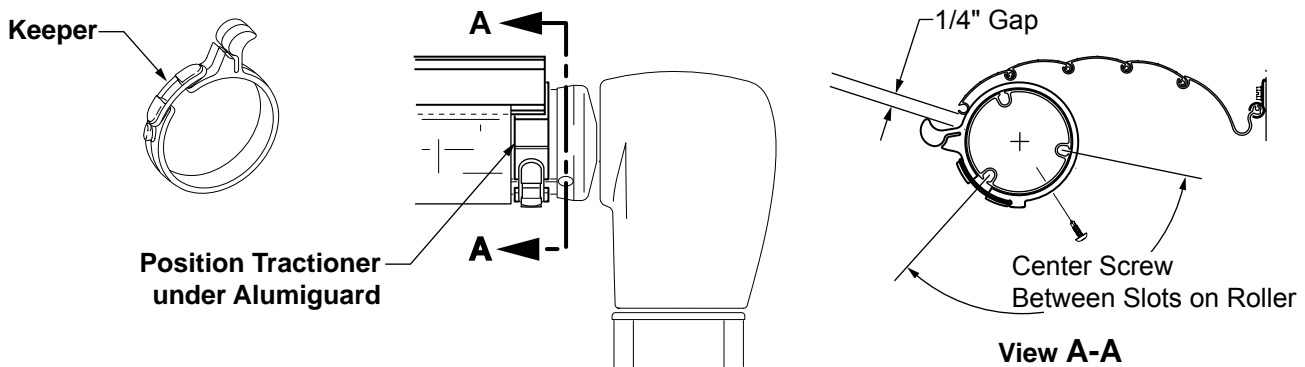

E0013

Figure 13. Installing the Alumaguard Tractioner.

OPERATION

SWITCH OPERATION – WALL MOUNTED

To extend or retract the awning press and hold the exterior switch until the awning is in the desired position. Release the switch.

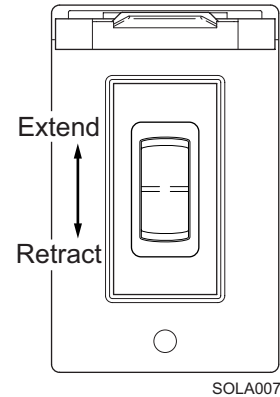

Figure 14. Switch Operation.

EMERGENCY OPERATION

If the original 110VAC power source fails or is unavailable, the Sola can be retracted/extended using a 9V-18V power source, such as a cordless drill battery or car battery.

⚠️WARNING

DO NOT CONNECT THE SOLA MOTOR TERMINALS TO A 110V POWER SOURCE! DOING SO WILL PERMANENTLY DAMAGE THE AWNING!

1. Disconnect the external plug.
2. Remove the switch cover, and switch plate from the switch outlet box.
3. Disconnect the motor cable wires from the switch terminals (2B and 5B).
4. Using jumpers, attach the jumper leads to the motor cable.
3. Connect the other ends of the jumper leads to a 12V source. If the awning does not begin to move, reverse the leads.
4. Maintain contact throughout the retraction process.

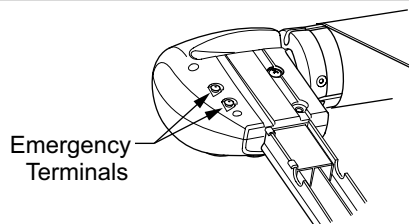
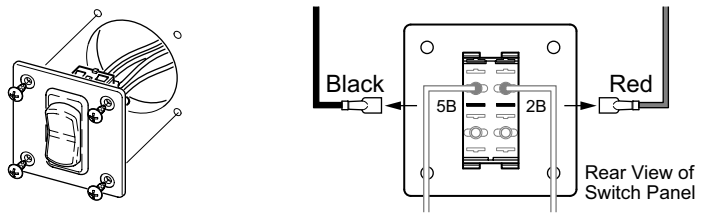

TravelR010

Figure 15. Emergency Operation.

⚠️CAUTION

BE CAREFUL WHEN RETRACTING THE AWNING AS THE AWNING MAY MOVE ABRUPTLY.

ADJUSTING THE PITCH

Figure 16 shows the maximum and minimum pitch settings. The awning can extend and retract in these positions or any position in between, without having to reset the pitch between uses.

⚠ CAUTION

BE CAREFUL WHEN ADJUSTING THE PITCH AS THE AWNING MAY MOVE ABRUPTLY.

(Refer to Figure 16)

1. Extend the awning completely. It is easier to adjust the pitch when the awning is fully extended.
2. Hold on to the arm of the awning to keep it steady while adjusting the pitch.
3. Press the pitch adjustment pins, located on the long scissor arm. There are two pins: one in the outer channel (shown) and one in the inner channel.

Tip: Applying LIGHT pressure on the arm will decrease the force required to press the pitch adjustment pins.

4. Slide the outer scissor arm to the desired set of holes—towards the building for a lower pitch and away from the building for a higher pitch.

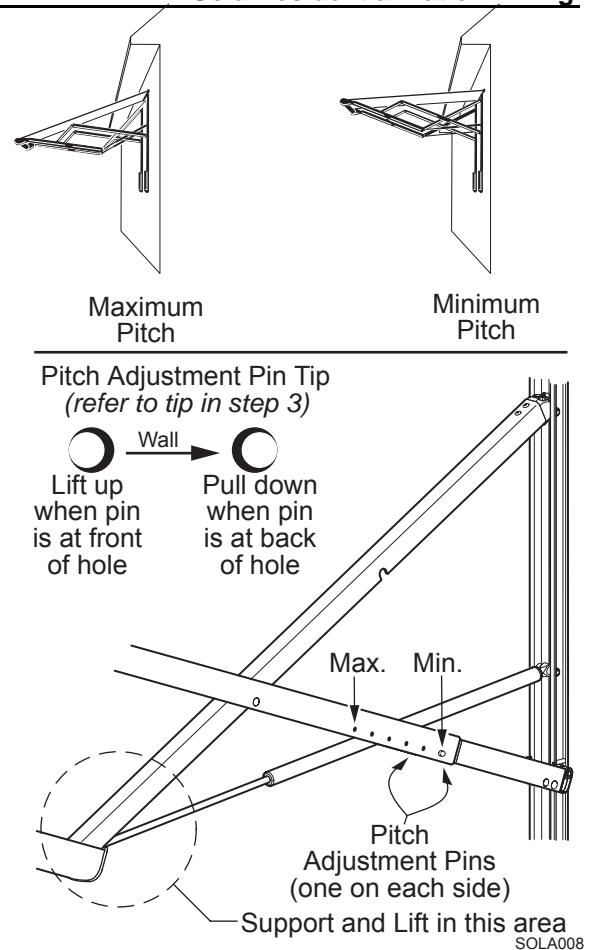

Figure 16. Pitch Adjustment.

RAIN RELEASE SETTING

The effects of wind and rain on an awning are unpredictable. Severe damage to the awning and/or the building may result. IF WIND OR EXTENDED PERIODS OF RAIN ARE EXPECTED, ROLL UP THE AWNING AND SECURE.

If the awning is extended during rain, position one arm at minimum pitch and the other arm at maximum pitch. This provides slope to allow the water to run off.

Note: The awning can be retracted with the arms set in the release setting. The pitch does not have to be equalized before closing.

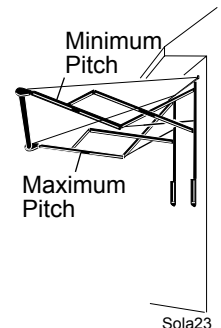

MAINTENANCE

Maintaining a Carefree Awning is easy. Just follow these basic steps:

- Always operate the awning according to the instructions.
- Periodically check that the fasteners are tight. Tighten if necessary.
- Keep the awning fabric and arms clean.

FABRIC CARE

CAUTION

DO NOT USE OIL BASED CLEANERS OR ANY CAUSTIC, GRANULATED, OR ABRASIVE TYPE CLEANERS ON YOUR CAREFREE PRODUCT.

1. One of the best ways to keep the fabric looking good and to delay the need for deep or vigorous cleanings is to hose fabrics off on a monthly basis with clear water. This practice will help prevent dirt from becoming deeply imbedded in the fabric. In most environments, a thorough cleaning will be needed every two to three years.
2. When it's time for a thorough cleaning, the fabric can be cleaned while still on the awning frame.
 - For Vinyl Fabric – Use a soft brush and warm water with soap.
 - For Acrylic Fabric – Use a stiff brush and warm water with soap.
3. When cleaning the fabric, it is important to observe the following:
 - Always use a natural soap, never detergent.
 - Water should be cold to lukewarm, never more than 100°F.
 - Air-dry only. Never apply heat to the fabric.
 - Always allow the fabric to dry thoroughly before rolling up the awning.

Mildew

Mildew is a fungus growth that looks like dirt. Vinyl coated polyester fabrics are mildew resistant because of a chemical biocide in the vinyl coating. Under ordinary conditions, mildew will not appear. However, in areas where high temperature and humidity are common, mildew can be a problem and require the material to be washed more frequently. Thoroughly rinse the fabric with clean water and allow to air dry completely before rolling up the awning.

Pooling

When water collects on the top of the fabric, this is known as "pooling". This can occur during inclement weather or if a running air conditioner discharges over the awning. The water is dumped when the awning is retracted. It is recommended that if water accumulates on the top; retract the awning in steps (8"-12") to dump the water. This will help prevent the fabric from stretching or distorting.

ARM CARE

The best method of keeping the arms operating smoothly is to clean them. Dirt and debris can cause the channels not to slide easily. **Avoid introducing water into the motorized and non-motorized housings.**

Periodically wash out the channels with running water (i.e. a hose) to keep them clean. If the arms still do not slide easily, lightly spray the pivot and contact points with a dry silicone lubricant after the arms have been cleaned and dried thoroughly.

MOTOR MAINTENANCE

- Check all wiring and connections for wear. Repair when needed.

LIMITED WARRANTY

Carefree of Colorado (hereafter referred to as Carefree) warrants to the FIRST retail Purchaser that the Sola Awning is free of defects in material and workmanship within the terms and conditions as set forth below. Carefree's obligation under this warranty is limited to the repair or replacement, at Carefree's option, of any defective component within the stated warranty period. THIS WARRANTY IS NOT TRANSFERABLE.

1. DURATION

- a) 5 years on motor and canopy.
- b) 10 years on springs, rollers and hardware.
- c) 12 months on electronic components.
- d) For the first 12 months, should a failure occur and the initial purchaser has proof of purchase (warranty card sent in or receipt of purchase) and notifies Carefree in a timely manner, all components, labor and freight are covered 100%.
- e) After the initial 12 months, any defects in the product will be replaced or repaired for a prorated amount of the cost of the part based upon the number of months since the initial date of purchase.

Warranty duration is not extended by the length of time the product is not in use or the time which the purchaser is deprived the use of the product. The duration of coverage is determined by the date of the original product purchase, not the date of repairs.

2. WHAT IS COVERED UNDER THIS WARRANTY

Defects in the manufacturer's material and workmanship of product under normal use, and which occur within the duration of the warranty period. The following components are covered only as listed:

- a) *Fabrics* – Free from quality defects (normal wear and fading are excluded). Cracking, peeling, hardening, sagging or loss of strength provided that the damage is not the result of high winds or water pooling.
- b) *Roller tube & Hardware* – Free from extrusion defects.
- c) *Springs* – Defect.
- d) *Motor and Electronics* – Defect.

3. WHAT IS NOT COVERED UNDER THIS WARRANTY

- a) Fabric damage such as pinholes or tears not reported within ten (10) calendar days of purchase.
- b) Improper installation and/or any damage or failure that results from improper installation of the product, including fabric damage caused by improper installation.
- c) Normal wear including the occasional need to re-tension the awning.
- d) Conditions that are not related to the material or workmanship of the product: including any failure that results from an accident, wind, rain, water pooling, or other acts of God.
- e) Purchaser's abuse, including but not limited to neglect; failure to operate, use or maintain the product in accordance with the instructions provided with the product.
- f) Any component not sold or manufactured by Carefree.
- g) Any failure that results from the use of another manufacturer's product with a Carefree product that is not specifically approved by Carefree.
- h) Any incidental, indirect, or consequential loss, damage, or expense that may result from any defect, failure, or malfunction of the Carefree product.
- i) The removal or alteration of any product component or device. In the event of such removal or alteration, this warranty is void.
- j) Any expense related to delivery or pick-up of product to/from the service dealer.

4. RESPONSIBILITIES OF THE PURCHASER

IN ORDER FOR THE WARRANTY TO BE HONORED, THE PURCHASER MUST HAVE PROOF OF PURCHASE: THE ORIGINAL RECEIPT OR THE WARRANTY CARD ON FILE AT CAREFREE OF COLORADO. FAILURE TO PROVIDE THE REQUIRED DOCUMENTATION MAY DELAY OR VOID ANY WARRANTY CLAIM.

- a) Retain dated proof of purchase for specified product, and provide it as requested.
- b) Inspect the awning upon purchase to confirm the condition of the canopy, hardware and proper operation of the product.
- c) Perform "Periodic Maintenance" as specified in Owners Manual.
- d) Use reasonable care in maintenance, operation, use and storage of the product in accordance with the instructions contained in the owner's manual.

5. WARRANTY CLAIM PROCEDURE

- a) Deliver any product claimed or found defective during warranty period to a Carefree of Colorado Authorized Service Dealer. Visit www.carefreeofcolorado.com for the name of nearest Authorized Service Dealer, or call Carefree at the phone number shown.
- b) Customer shall schedule a time with an Authorized Service Dealer. Repair or replacement will be scheduled and performed at the Authorized Service Dealer according to normal work flow and availability of replacement parts.
- c) *Work must be performed by a Carefree authorized service center.* When warranty work/repair is performed by an authorized service agent, the agent is responsible for directly billing Carefree of Colorado for warranted parts and labor.
- d) Carefree shall pay the respective servicing dealer or agent for performing any repairs authorized by Carefree as per the terms of this warranty. Company will allow for freight and labor charges - labor is based on Flat Rate Form.
- e) All warranty claims shall be paid through the servicing agent. Carefree does not provide reimbursement for warranty claims paid for by the customer.
- f) The customer shall pay only those costs not covered by warranty. The customer shall have no out-of-pocket expenses except as stated.
- g) The Original Purchaser is responsible for any expenses related to delivery or pick up of product to/from the Service Dealer.
- h) If the Purchaser does not receive satisfactory results from the Authorized Service Dealer, the Purchaser should contact the Carefree of Colorado Customer Care Department within 10 days after completion of the questionable service.

THIS WARRANTY GIVES THE OWNER SPECIFIC LEGAL RIGHTS. THE LAWS OF CERTAIN JURISDICTIONS MAY GRANT THE OWNER ADDITIONAL RIGHTS AND PRIVILEGES. Except as set forth above, Carefree makes no warranty, whether statutory or otherwise, including without limitation, any warranty of merchantability or fitness for a particular purpose. Carefree shall have no liability except to repair, replace or adjust defective products and parts. Carefree specifically excludes any liability, whether in contract, tort or otherwise, for personal injury, property damage, economic or consequential losses. Carefree has not authorized any person or company to alter the terms of this warranty.

It is Carefree of Colorado's policy and practice to continuously improve the company's products and services. Therefore, Carefree reserves the right to make changes in design and components, without notice, whenever it is believed the quality of the product will be improved, but without incurring any obligation to incorporate such improvements in any product which has been shipped or in service.

FOR YOUR RECORDS:

DEALER/INSTALLER NAME: _____

ADDRESS: _____

PHONE: _____

PURCHASE DATE: _____

PART NUMBER: _____

SERIAL NUMBER: _____

PRODUCT NAME OR DESCRIPTION: _____

Color: _____ **Length:** _____

Register your Carefree products on-line @ www.carefreeofcolorado.com



www.carefreeofcolorado.com