

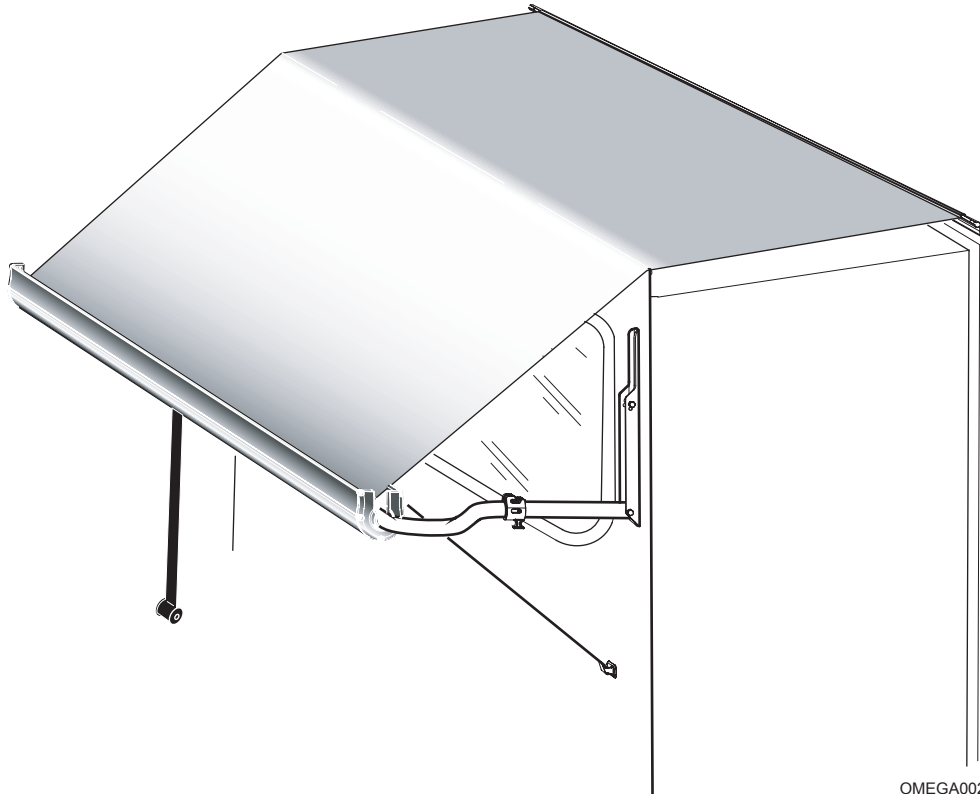

CAREFREE

# OMEGA II

Side-Out Kover and Window Awning



OMEGA002

# TABLE OF CONTENTS

<b>Introduction .....</b>	<b>1</b>
Product Overview .....	1
Component Checklist.....	1
<b>Installation .....</b>	<b>2</b>
Before Installing the Awning .....	2
Installing an Awning Rail.....	3
Installing the Awning.....	3
Mounting the Arms.....	4
Securing the Fabric.....	5
Attaching the Case .....	5
Mounting the Hold-Down Strap Catches .....	6
<b>Operating the Omega II Awning .....</b>	<b>7</b>
Extending the Awning .....	7
Retracting the Awning.....	7
Stowing the Strap .....	8
Fabric Maintenance .....	8
Mildew .....	8
Hardware Maintenance.....	8
<b>Carefree Limited Warranty.....</b>	<b>9</b>

## SAFETY INFORMATION

### **WARNING**

**A WARNING INDICATES A POTENTIALLY HAZARDOUS SITUATION WHICH , IF NOT AVOIDED, COULD RESULT IN DEATH OR SERIOUS INJURY AND/OR MAJOR PROPERTY DAMAGE.**

### **CAUTION**

**A CAUTION INDICATES A POTENTIALLY HAZARDOUS SITUATION THAT MAY CAUSE MINOR TO MODERATE PERSONAL INJURY AND/OR PROPERTY DAMAGE. IT MAY ALSO BE USED TO ALERT AGAINST UNSAFE PRACTICES.**

**NOTE: A note indicates further information about a product, part, or step.**

*Tip: A tip provides helpful suggestions.*

#### *Safety Notes:*

- Always disconnect battery or power source before working on or around the electrical system.
- Always wear appropriate safety equipment (i.e. goggles).
- Always use appropriate lifting devices and/or helpers when lifting or holding heavy objects.

# INTRODUCTION

## PRODUCT OVERVIEW

The Carefree Omega II awning is a combination slide-out cover and window awning. As a slide-out cover, the fabric extends and retracts by automatically following the room's movements. The window awning is manually operated. Simply pull the center pull strap to extend the awning and attach the tie straps to the catches. For travel, the awning arms securely lock into the upright position.

## COMPONENT CHECKLIST

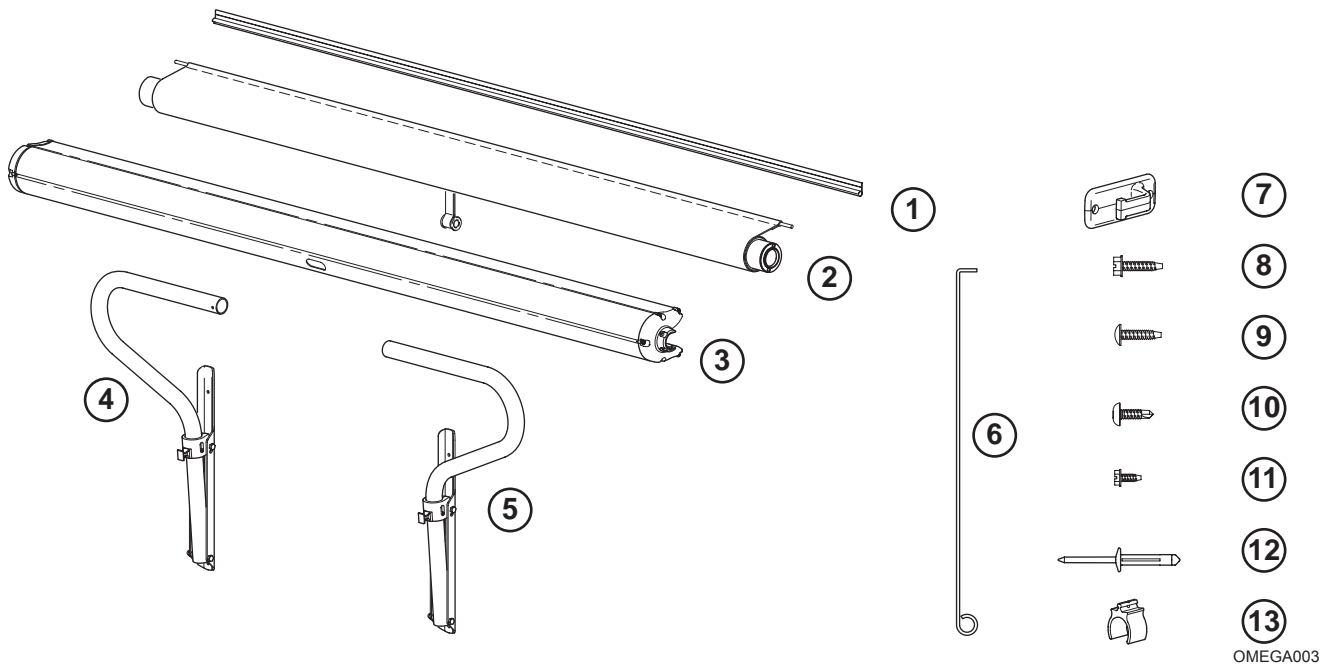

Figure 1. Component Checklist.

<input checked="" type="checkbox"/> ITEM	DESCRIPTION	QTY	NOTE
<b>BASIC COVER ASSEMBLY</b>			
<input type="checkbox"/> 1	Awning Rail	1	
<input type="checkbox"/> 2	Roll Bar Assy	1	
<input type="checkbox"/> 3	Case Assy	1	
<input type="checkbox"/> 4	Left Arm Assy	1	
<input type="checkbox"/> 5	Right Arm Assy	1	
<input type="checkbox"/> 6	Pull Cane	1	
<input type="checkbox"/> 7	Attach Strap Catch	2	
<input type="checkbox"/> 8	Screw, Hex Head	#10 x 3/4 30	
<input type="checkbox"/> 9	Screw, Pan Head	#10 x 3/4 4	
<input type="checkbox"/> 10	Screw, Truss Head, Sq Drive	#6 x 5/8 4	
<input type="checkbox"/> 11	Screw, Hex Head	#6 x 3/8 2	
<input type="checkbox"/> 12	Rivet, Moly	3/16 6	
<input type="checkbox"/> 13	Clip, Pull Strap Stow	1	

**NOTE:**

1. On some units, the case assy (item 3) comes partially assembled. The installer must install the clip (item 13) and the end cap.

# INSTALLATION

## BEFORE INSTALLING THE AWNING

1. Park the vehicle on a flat surface and level the unit.
2. If using an existing awning rail:
  - Check that the rail runs the entire length of the awning to be installed.
  - The centerline of the rail must be mounted a minimum of 1" above the uppermost edge of the slide-out face.

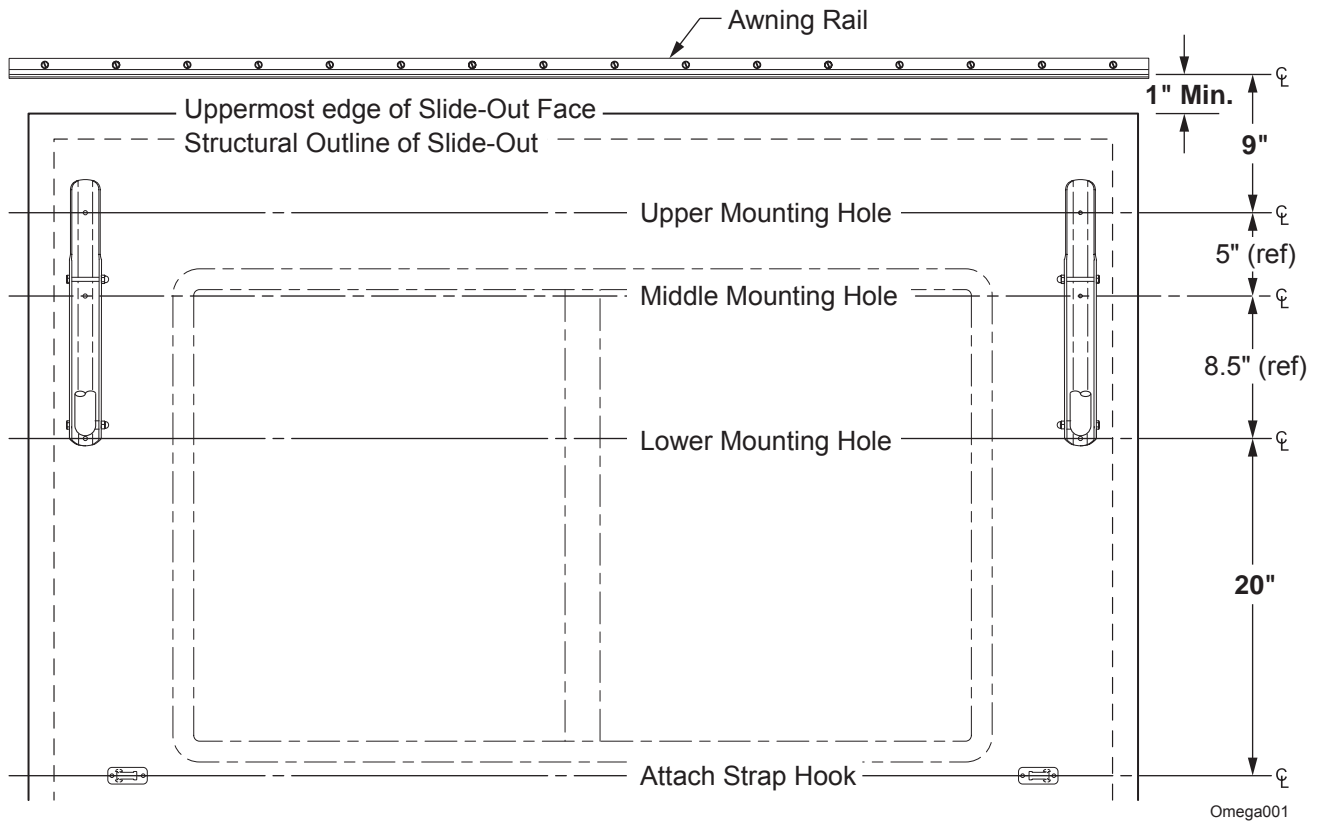

**Figure 2. Awning Layout.**

3. The arms will mount on the slide-out face.
  - The mounting surface must be a minimum of 1 1/16" wide.
  - The attaching screws must go into the slide-out structure and not just through the outer portion of the face flange. The screws must not interfere with the room's ability to close and seal.
4. If an existing awning rail is used, skip to step 7 under "Installing an Awning Rail".

### INSTALLING AN AWNING RAIL

1. Determine the positioning of the awning.
2. The awning rail must be parallel to the uppermost edge of the slide-out.
3. The awning rail must be a minimum of 1" above the uppermost edge of the slide-out.

#### **⚠CAUTION**

**THE AWNING RAIL MUST BE POSITIONED HIGH ENOUGH TO NOT INTERFERE WITH THE SLIDE-OUT'S ABILITY TO CLOSE AND SEAL.**

4. After determining the mounting position, mark the position with a chalk line.
5. Seal the back of the rail with silicone sealant or putty tape.
6. Align the awning rail onto the wall and secure with #10 x 3/4 screws. Use all the attach holes in the rail.

#### **⚠CAUTION**

**MAKE SURE THAT THE SCREWS MOUNT SECURELY TO THE STRUCTURAL FRAME OF THE VEHICLE.**

7. (refer to figure 3) Use a screwdriver to spread open one end of the awning rail on the installation side.

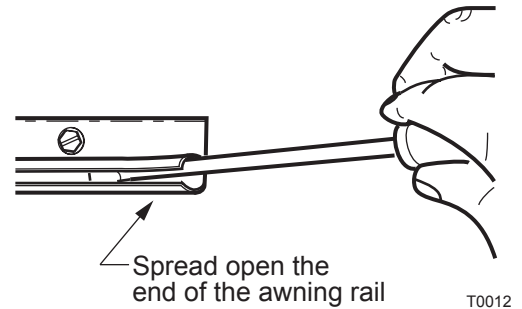

**Figure 3. Adjusting the Awning Rail.**

8. File any sharp edges or burrs from the end of the rail. This will help protect the awning fabric from damage during installation.
9. Spray inside the awning rail track with silicon lubricant.

### INSTALLING THE AWNING

1. Slide the polyrod and awning into the awning rail.

#### **⚠CAUTION**

**DO NOT ALLOW THE FABRIC TO UNROLL MORE THAN ONE THIRD OF A WRAP.**

2. Center the fabric over the slide-out.

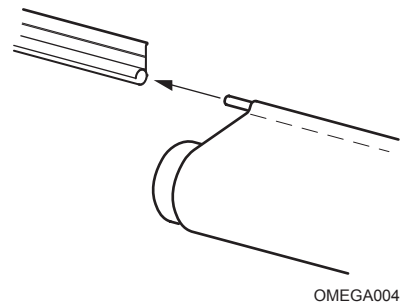

**Figure 4. Mounting the Awning.**

## MOUNTING THE ARMS

1. (refer to Figure 2) Mark the vertical position of the upper mounting hole. It should be 9" below the center of the awning rail.
2. (refer to Figure 5) Slide the right arm into the roller assembly. There must be a minimum of 1 3/4" from the end of the roller to the start of the curve in the arm.

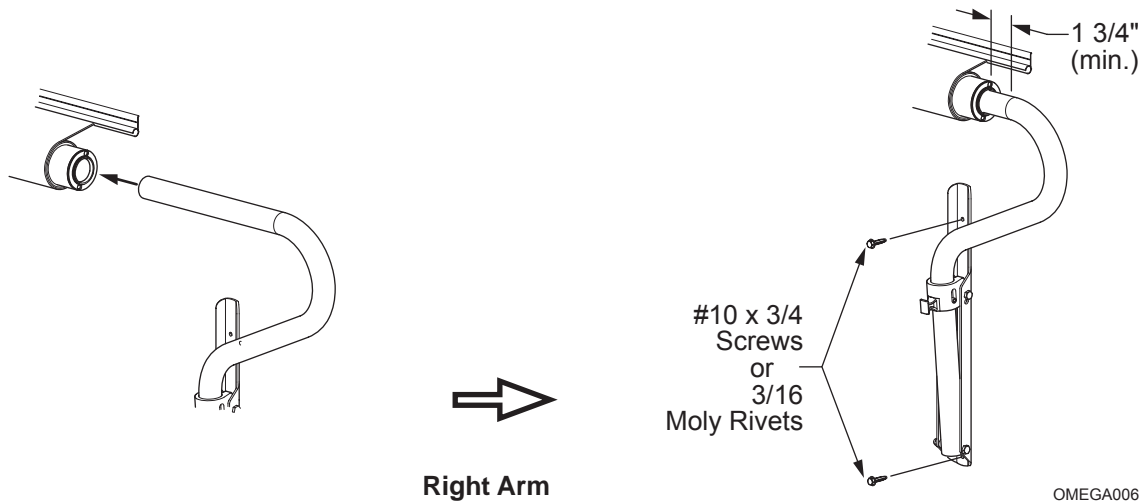

Figure 5. Mounting the Right Arm.

3. Position the arm on the coach:
  - Align the upper mounting hole of the mounting bracket with the position marked in step 1;
  - Align the roller parallel with the awning rail;
  - Ensure the arm is perpendicular to the roller.
4. Attach the mounting bracket at the top and bottom mounting holes using #10 x 3/4 hex head screws.
 

**NOTE: If mounting into a hollow wall, drill a 7/32" hole and use a 3/16" moly-rivet to attach the arm.**
5. Align the rivet inside the left arm with the slot in the spring adaptor. Slide the left arm assembly over the spring adapter, the rivet inside the arm must engage the slot of the spring adaptor. Rotate the arm until the rivet catches into place.

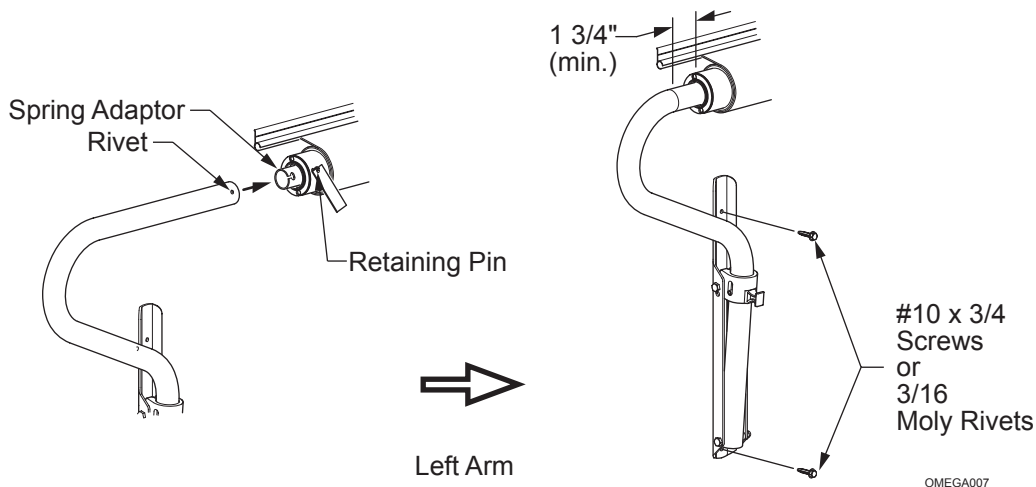

Figure 6. Mounting the Left Arm.

6. Firmly grasp the arm and roller assembly. Remove the retaining pin from the roller.

**! CAUTION**

**THE RETAINING PIN IS USED TO HOLD THE PRE-WOUND SPRING TENSION IN THE ROLLER ASSEMBLY. USE CARE WHEN REMOVING THE PIN TO AVOID SUDDEN MOVEMENT OF THE ARM AND/OR ROLLER WHEN THE PIN IS REMOVED.**

7. Press the arm into the roller.
8. Repeat steps 3 and 4 to attach the left arm.
9. Slide the arm locks upward to release the arms.
10. Pull the arms outward to expose the middle mounting holes.
11. Attach the left and right arms in the center holes using the #10 x 3/4 screws or moly rivets.
12. Allow the arms to rise up to the closed position.
13. Slide the arm locks down to lock the arms in the upright position.

**SECURING THE FABRIC**

1. Extend and retract the slide-out several times. Leave the room extended out.
2. Confirm that the awning is centered, and rolls up straight.
3. Attach the fabric in the awning rail at each end using a #6 x 3/8 screw. Position the screw approximately 1" from the edge of the fabric.

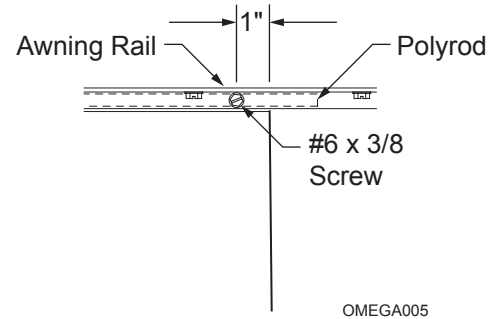
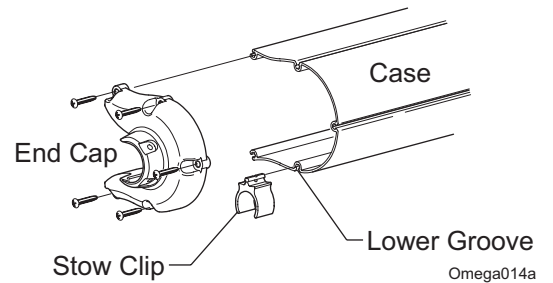

**Figure 7. Attaching the Fabric.**

**ATTACHING THE CASE**

**NOTE: For units with the pull strap stow clip already installed go to step 4.**

1. On the case, slide the stow clip into the lower groove of the case.
2. Install the end cap with the furnished screws
3. Slide the clip down to the area where the pull strap will project out of the case. Secure the clip by tightening the #6 set screw.
4. Lift the case up to the top of the ladders or platforms used during assembly.



**Figure 8. Installing the Stow Clip.**

**NOTE: The slot in the case is in the lower half of the case.**

5. Thread the center pull strap through the slot and plastic bezel in the case. It will be necessary to squeeze the rubber grommet at the end of the strap to get it through the hole.
6. Lift the case up and press onto the arms. Center the case over the roller and orient the case as shown in figure 8.
7. Secure the case to the arms using two (2) square drive self-tapping screws on each end.

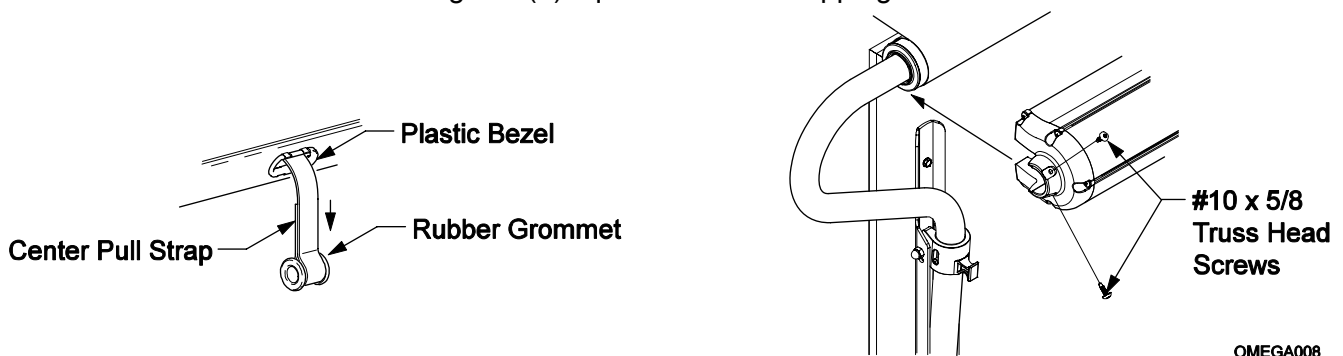

**Figure 9. Installing the Case.**

### MOUNTING THE HOLD-DOWN STRAP CATCHES

1. (refer to Figure 2) Measure down 20 inches from the bottom mounting screw of the arm bracket.
2. Horizontally position the catch to avoid windows etc.

**NOTE: When the awning is fully extended, the straps can slide horizontally along the roller to match the desired location.**

3. Attach the catches using two (2) #10 x 3/4 pan head screws.
4. Repeat for the other side.

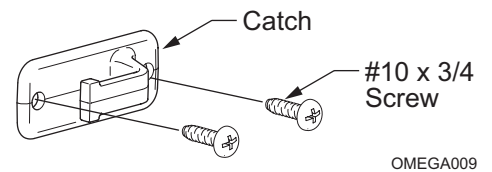

**Figure 10. Hold-Down Strap Catch.**



# OPERATING THE OMEGA II AWNING

**⚠ CAUTION**

**THE SLIDE-OUT ROOM SHOULD ALWAYS BE EXTENDED FULLY BEFORE EXTENDING THE AWNING. THE AWNING SHOULD BE CLOSED BEFORE RETRACTING THE SLIDE-OUT ROOM. EXTENDING OR RETRACTING THE SLIDE-OUT ROOM WITH THE AWNING EXTENDED CAN CAUSE UNNECESSARY WEAR AND DAMAGE TO THE AWNING FABRIC AND THE SLIDE-OUT SEALS.**

## EXTENDING THE AWNING

1. Extend the slide-out room to its full extension.

**NOTE: The awning automatically extends and retracts over the slide-out room.**

2. Using the pull cane, push the arm locks upward to the unlocked position.
3. Hook or grasp the center pull strap and pull down.
4. Hook the outside hold-down straps onto the catches.

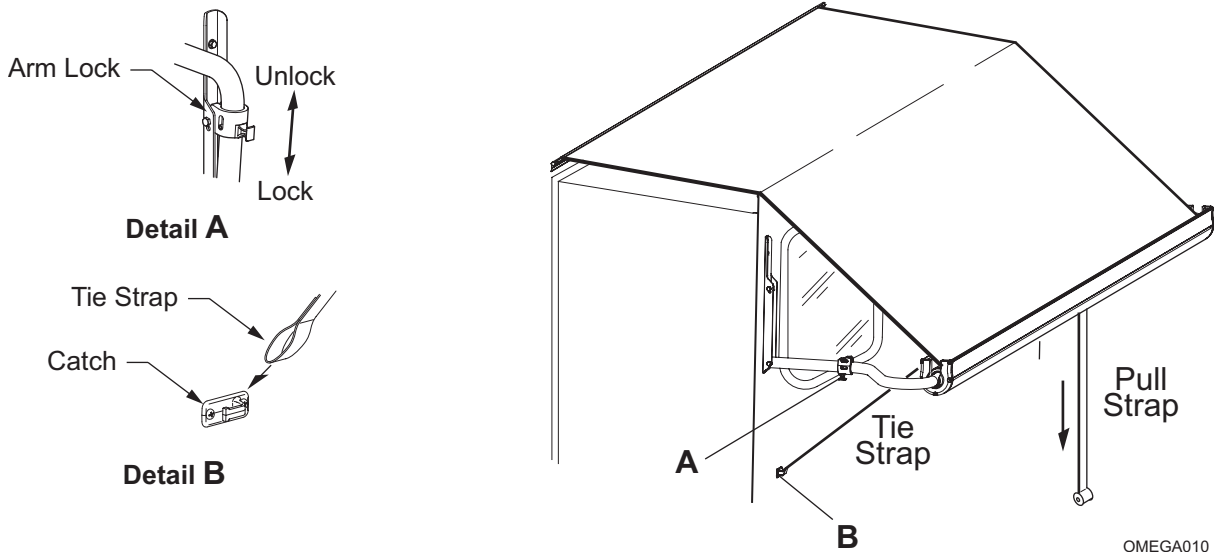

**Figure 11. Opening the Awning.**

## RETRACTING THE AWNING

1. Grasp the center pull strap and unhook the outside hold-down straps.
2. While holding the center pull strap, allow the awning to roll up to the stored position.

**⚠ CAUTION**

**DO NOT RELEASE THE STRAP UNTIL THE AWNING IS AGAINST THE SLIDE-OUT FACE. RELEASING THE STRAP EARLY WILL CAUSE THE AWNING TO SLAM AGAINST THE SLIDE-OUT FACE POSSIBLY CAUSING DAMAGE TO THE AWNING AND/OR VEHICLE.**

3. Using the pull cane, pull the arm locks down into the locked position.

**⚠ CAUTION**

**ALWAYS ENSURE THAT THE ARMS ARE LOCKED IN THE UPRIGHT POSITION BEFORE MOVING THE VEHICLE.**

4. The room may now be retracted.

## STOWING THE STRAP

When the awning is open, the pull strap will hang down loosely. Use the pull cane and press the pull strap grommet into the clip to keep the strap from flopping.

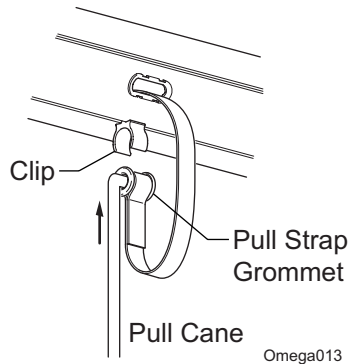

**Figure 12. Stowing the Pull Strap.**

## FABRIC MAINTENANCE

### **⚠ CAUTION**

**DO NOT USE OIL BASED CLEANERS OR ANY CAUSTIC, GRANULATED, OR ABRASIVE TYPE CLEANERS ON YOUR CAREFREE PRODUCT.**

1. One of the best ways to keep the fabric looking good and to delay the need for deep or vigorous cleanings is to hose fabrics off on a monthly basis with clear water. This practice will help prevent dirt from becoming deeply imbedded in the fabric and eliminate the need for more frequent vigorous cleanings. In most environments, a thorough cleaning will be needed every two to three years.
2. When it's time for a thorough cleaning, the fabric can be cleaned while still on an awning frame.
  - For Vinyl Fabric – Use a soft brush and warm water with soap.
  - For Acrylic Fabric – Use a stiff brush and warm water with soap.
3. When cleaning the fabric, it is important to observe the following:
  - Always use a natural soap. Never detergent.
  - Water should be cold to lukewarm. Never more than 100 degrees.
  - Air-dry only. Never apply heat to the fabric.
4. To clean inside the case:
  - Close the side-out room.
  - Pull the awning down. The awning will be able to extend down to the wall. Secure the awning as required.
  - Using a hose, wash out the inside of the case.

### *Mildew*

Mildew is a fungus growth that looks like dirt. Vinyl coated polyester fabrics are mildew resistant because of a chemical biocide in the vinyl coating. Under ordinary conditions, mildew will not appear. However, in areas where high temperature and humidity are common, mildew can be a problem and require the material to be washed more frequently. THOROUGHLY rinse the fabric with clean water and allow to air dry completely before rolling up the awning.

## HARDWARE MAINTENANCE

- Replace any parts that become damaged.
- Periodically check all mounting hardware, screws, lags, etc., and re-tighten when necessary.
- Periodically flush the case with low pressure water to keep it clean and free of debris.

## CAREFREE LIMITED WARRANTY

Carefree of Colorado (hereafter referred to as Carefree) warrants to the FIRST retail Purchaser that the Omega II is free of defects in material and workmanship within the terms and conditions as set forth below. Carefree's obligation under this warranty is limited to the repair or replacement, at Carefree's option, of any defective component within the stated warranty period. THIS WARRANTY IS NOT TRANSFERABLE.

### 1. DURATION

- a) 2 years on parts, labor and freight on parts labor and freight on canopy.
- b) 4 years on parts, labor and freight on springs, rollers and hardware.

Warranty duration is not extended by the length of time the product is not in use or the time which the purchaser is deprived the use of the product. The duration of coverage is determined by the date of the original product purchase, not the date of repairs.

### 2. WHAT IS COVERED UNDER THIS WARRANTY

Defects in the manufacturer's material and workmanship of product under normal use, and which occur within the duration of the warranty period. The following components are covered only as listed:

- a) *Fabrics* – Free from quality defects (normal wear and fading are excluded). Cracking, peeling, hardening, sagging or loss of strength provided that the damage is not the result of high winds or water pooling.
- b) *Roller tube & Hardware* – Free from extrusion defects.
- c) *Springs* – Defects.

### 3. WHAT IS NOT COVERED UNDER THIS WARRANTY

- a) Fabric damage such as pinholes or tears not reported within ten (10) calendar days of purchase.
- b) Improper installation and/or any damage or failure that results from improper installation of the product, including fabric damage caused by improper installation.
- c) Normal wear including the occasional need to re-tension the awning.
- d) Conditions that are not related to the material or workmanship of the product: including any failure that results from an accident, wind, rain, water pooling, or other acts of God.
- e) Purchaser's abuse, including but not limited to neglect; failure to operate, use or maintain the product in accordance with the instructions provided with the product.
- f) Any component not sold or manufactured by Carefree.
- g) Any failure that results from the use of another manufacturer's product with a Carefree product that is not specifically approved by Carefree.
- h) Any incidental, indirect, or consequential loss, damage, or expense that may result from any defect, failure, or malfunction of the Carefree product.
- i) The removal or alteration of any product component or device. In the event of such removal or alteration, this warranty is void.
- j) Any expense related to delivery or pick-up of product to/from the service dealer.

### 4. RESPONSIBILITIES OF THE PURCHASER

IN ORDER FOR THE WARRANTY TO BE HONORED, THE PURCHASER MUST HAVE PROOF OF PURCHASE: THE ORIGINAL RECEIPT OR THE WARRANTY CARD ON FILE AT CAREFREE OF COLORADO. FAILURE TO PROVIDE THE REQUIRED DOCUMENTATION MAY DELAY OR VOID ANY WARRANTY CLAIM.

- a) Retain dated proof of purchase for specified product, and provide it as requested.
- b) Inspect the product upon purchase to confirm the and proper operation of the product.
- c) Perform "Periodic Maintenance" as specified in Owners Manual.
- d) Use reasonable care in maintenance, operation, use and storage of the product in accordance with the instructions contained in the owner's manual.

### 5. WARRANTY CLAIM PROCEDURE

- a) Deliver any product claimed or found defective during warranty period to a Carefree of Colorado Authorized Service Dealer. Visit [www.carefreeofcolorado.com](http://www.carefreeofcolorado.com) for the name of nearest Authorized Service Dealer, or call Carefree at the phone number shown.
- b) Customer shall schedule a time with an Authorized Service Dealer. Repair or replacement will be scheduled and performed at the Authorized Service Dealer according to normal work flow and availability of replacement parts.
- c) *Work must be performed by a Carefree authorized service center.* When warranty work/repair is performed by an authorized service agent, the agent is responsible for directly billing Carefree of Colorado for warranted parts and labor.
- d) Carefree shall pay the respective servicing dealer or agent for performing any repairs authorized by Carefree as per the terms of this warranty. Company will allow for freight and labor charges - labor is based on Flat Rate Form.
- e) All warranty claims shall be paid through the servicing agent. Carefree does not provide reimbursement for warranty claims paid for by the customer.
- f) The customer shall pay only those costs not covered by warranty. The customer shall have no out-of-pocket expenses except as stated.
- g) The Original Purchaser is responsible for any expenses related to delivery or pick up of product to/from the Service Dealer.
- h) If the Purchaser does not receive satisfactory results from the Authorized Service Dealer, the Purchaser should contact the Carefree of Colorado Customer Care Department within 10 days after completion of the questionable service.

THIS WARRANTY GIVES THE OWNER SPECIFIC LEGAL RIGHTS. THE LAWS OF CERTAIN JURISDICTIONS MAY GRANT THE OWNER ADDITIONAL RIGHTS AND PRIVILEGES. Except as set forth above, Carefree makes no warranty, whether statutory or otherwise, including without limitation, any warranty of merchantability or fitness for a particular purpose. Carefree shall have no liability except to repair, replace or adjust defective products and parts. Carefree specifically excludes any liability, whether in contract, tort or otherwise, for personal injury, property damage, economic or consequential losses. Carefree has not authorized any person or company to alter the terms of this warranty.

It is Carefree of Colorado's policy and practice to continuously improve the company's products and services. Therefore, Carefree reserves the right to make changes in design and components, without notice, whenever it is believed the quality of the product will be improved, but without incurring any obligation to incorporate such improvements in any product which has been shipped or in service.

