

# CAREFREE OMEGA AWNING

## MANUAL LOCK UPDATE INSTRUCTIONS

052962-001

**THE OMEGA MANUAL LOCK UPDATE IS INSTALLED ON THE LEFT SIDE ARM ONLY. PLEASE FOLLOW THESE INSTRUCTIONS FOR PROPER INSTALLATION.**

**TO ADD MANUAL LOCK TO THE OMEGA ARM, DO THE FOLLOWING:**

- A. Extend slideout room approximately 1 foot.
- B. Move to the arm on the left hand side. Slide arm slide lock up to the unlocked position.
- C. Locate the plastic plug in the bottom of the tubular arm. Take a piece of tape and tape the plug to the arm channel. This will help prevent the plastic plug from falling out of the arm when the bolt is removed.
- D. Remove the 1/4" cap nut from the bolt that attaches the arm to the arm mounting bracket.
- E. Carefully remove the 1/4" x 20 bolt from the arm channel. *Note: Take care not to lose the (2) plastic spacers that are located on the outside of the tubular arms. These are necessary to keep the arms properly spaced for proper operation.*
- F. Carefully slide complete arm out of the roller tube.
- G. Remove existing anti-billow device located on the tubular arm.
- H. Replace that anti-billow device with the manual lock upgrade. Do not attach at this time.
- I. Slide arm channel back into roller tube assembly.
- J. Re-attach the tubular arm to the arm mounting bracket using the previously removed 1/4" x 20 bolt and cap nut. Make sure the (2) previously removed plastic spacers are put back into place between the tubular arm and the arm mounting bracket.
- K. Capture anti-billow device on to arm channel with the set screw previously removed.
- L. Rotate the anti-billow device until it is located as follows.

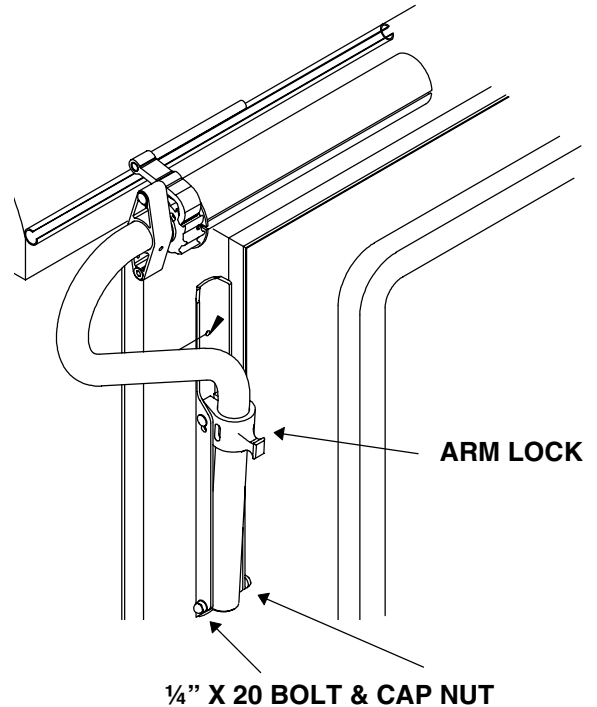

## OMEGA MANUAL LOCK UPDATE KIT INSTRUCTIONS (CONT.)

M. Retract slideout room completely. Once the room is completely retracted, position the roller lock assembly by pushing the manual lock lever up to the unlocked position and pushing down on the upper roller lock until it is full engaged in the sprocket. At this point there should be  $\frac{1}{2}$ " to  $\frac{3}{4}$ " of clearance between the bottom of the upper control rod and the fabric as shown at right.

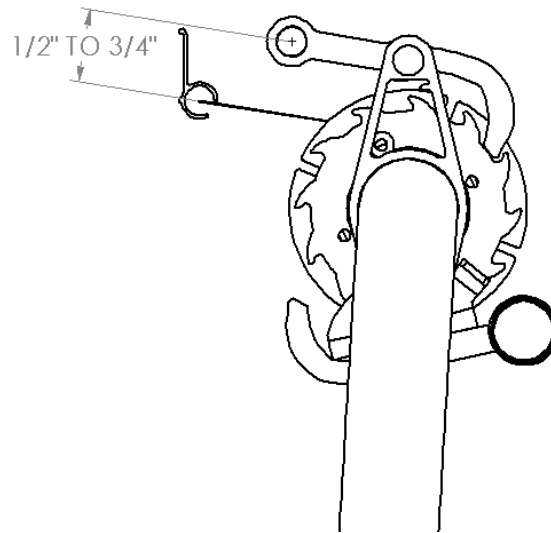

N. Rotate roller lock until this clearance has been obtained. ATTACH THE ROLLER BRACKET AT THIS POINT TO THE TUBULAR ARM BY INSTALLING A #10 X  $\frac{3}{4}$ " HEX HEAD TEK SCREW THROUGH THE HOLE IN THE ROLLER BRACKET AND INTO THE TUBULAR ARM. Once you release the roller lock, the roller should be able to rotate freely without the latch engaging the roller sprocket. Repeat this step for the back arm.

**NOTE: VERIFY THAT THE MANUAL LOCK LEVER OPERATES FREELY AND DOES NOT HAVE ANY INTERFERENCE WITH THE SLIDEOUT FACE OR THE BODY OF THE COACH.**

**NOTE: IF THE EXTRUDED POINT OF THE POSITIVE LOCK LEVER FALLS ON A HIGH SIDE OF THE SPROCKET WHEN THE ROOM AND AWNING ARE COMPLETELY RETRACTED IT WILL STILL FUNCTION PROPERLY. IF THE ROLLER STARTS TO TURN IT WILL AUTOMATICALLY ENGAGE IN THE NEXT SLOT ON THE SPROCKET.**

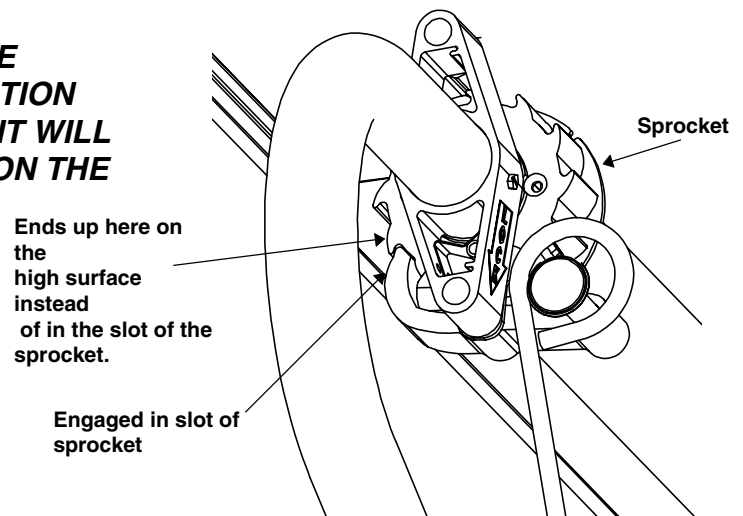

## **IMPORTANT!**

**WARNING LABELS MUST BE APPLIED ONCE THE INSTALLATION IS COMPLETE!  
PEEL THE PAPER OFF OF THE BACK OF THE TWO THIN RED WARNING LABELS AND ADHERE THE WARNING LABELS WHERE THEY WILL BE IN PLAIN SIGHT NEXT TO THE SLIDEOUT OPERATING SWITCH OR ON THE SLIDEOUT SAFETY JACK OR THE ROOM TRAVEL LOCK BRACE. PLACE THE THICKER RED LABEL OVER THE OPERATING SWITCH AS DESCRIBED IN THE ATTACHED COLORED SHEET OF PAPER. THESE LABELS MUST BE PUT INTO PLACE TO ENSURE THE CUSTOMER KNOWS TO LOCK THE MANUAL LOCK FOR TRAVEL AND UNLOCK IT BEFORE EXTENDING ROOM! FAILURE TO DO THIS COULD RESULT IN DAMAGE TO BOTH THE AWNING AND THE RV!**

# OPERATING INSTRUCTIONS

## 1. TO EXTEND OMEGA AWNING

- A. Grasp pull cane and push the red locking lever on the roller lock up to the unlocked position.  
**WARNING: FAILURE TO PUSH THE LOCK UP TO THE UNLOCKED POSITION PRIOR TO EXTENDING THE SLIDEOUT ROOM WILL RESULT IN DAMAGE TO THE AWNING AND THE RV!**

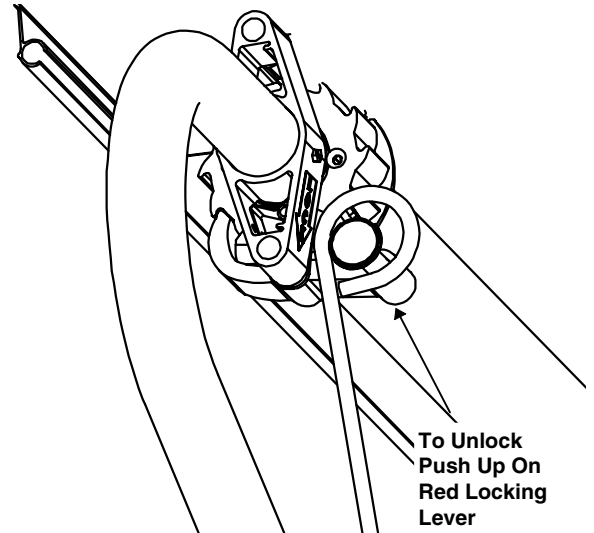

- B. Extend slideout to its full extension.
- C. The Omega awning will automatically unroll attaining full coverage when slideout achieves maximum extension.  
**NOTE: ROOM MUST EXTEND STRAIGHT (EQUAL AT BOTH ENDS) IN ORDER FOR THE FABRIC TO TIGHTEN UP UPON FULL EXTENSION!**
- D. Grasp pull cane and push arm locks up to the unlocked position.
- E. Grasp or hook center pull strap loop and unroll the awning and hook the loops of the other pull straps onto the pull strap catches.  
**NOTE: WATER MAY POOL ON TOP OF THE EXTENDED OMEGA. THE WATER WILL BE DUMPED AUTOMATICALLY AS THE SLIDEOUT IS RETRACTED.**

## 2. TO RETRACT OMEGA AWNING

- A. Remove loops of pull straps from catches and grasp center pull strap allowing awning to roll up to its stored position against the slideout face. Use the pull cane to assist in this. **CAUTION: DO NOT RELEASE STRAP UNTIL THE AWNING IS AGAINST THE SLIDEOUT FACE. THIS SPRING RETURN WILL RAPIDLY ROLL UP AWNING RESULTING IN A SLAM AGAINST THE SLIDEOUT FACE, POSSIBLY DAMAGING THE RV OR AWNING!**

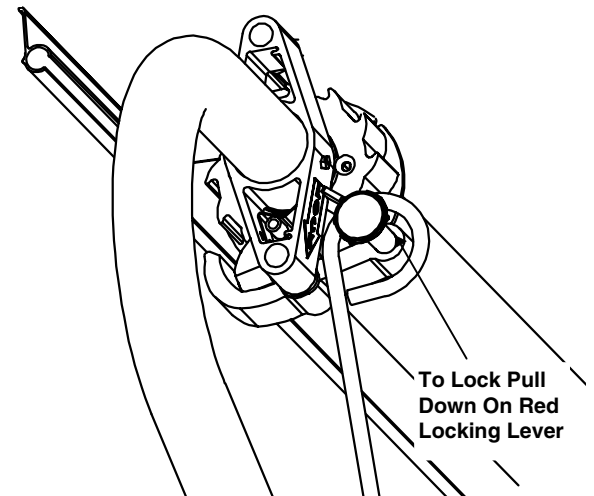

- B. Grasp pull cane and pull arm locks down to the locked position.
- C. Retract slideout to the complete closed position.  
**NOTE: WHEN RETRACTING SLIDEOUT IT IS A GOOD IDEA TO STOP THE ROOM HALFWAY IN AND ENSURE FABRIC IS ROLLING PROPERLY BEFORE CONTINUING RETRACTION.**
- D. Once the room is retracted, grasp the pull cane and pull down on the red locking lever of the roller lock until you hear a click. This will then be in the fully locked position. **WARNING: ROLLER LOCK MUST BE ENGAGED PRIOR TO TRAVEL! FAILURE TO DO THIS COULD RESULT IN BILLOWING AND DAMAGE TO THE AWNING AN THE RV WHICH WILL NOT BE COVERED BY WARRANTY!**