



# INSTALLATION MANUAL FREEDOM WM AWNING

**RV**

## MOTORIZED OR MANUAL LATERAL ARM BOX AWNING



Read this manual before installing or using this product. Failure to follow the instructions and safety precautions in this manual can result in personal injury and/or cause the product to not operate properly.



### TABLE OF CONTENTS

<b>Product Overview</b> .....	<b>1</b>
Component Checklist.....	2
<b>Installation</b> .....	<b>3</b>
Attaching the Mounting Plates .....	3
Mounting the Awning.....	4
Mounting to a Roof Rack.....	4
Installation Using an Awning Rail .....	5
Bottom Bracket Installation.....	6
Manual Crank Handle Storage Clips .....	6
<b>Switch Installation (motorized awnings only)</b> .....	<b>7</b>
<b>Optional LED Lighting</b> .....	<b>8</b>
Switch Installation .....	8
<b>Pitch Adjustment</b> .....	<b>9</b>
<b>Manual Override (motorized versions only)</b> .....	<b>9</b>
<b>Setting the Motor Limits</b> .....	<b>10</b>
Adjusting the OUT Limit Switch .....	10
Adjusting the IN Limit Switch .....	10

## PROPRIETARY STATEMENT

The Freedom Awning is a product of Carefree of Colorado, located in Broomfield, Colorado, USA. The information contained in or disclosed in this document is considered proprietary to Carefree of Colorado. Every effort has been made to ensure that the information presented in the document is accurate and complete. However, Carefree of Colorado assumes no liability for errors or for any damages that result from the use of this document.

The information contained in this manual pertains to the current configuration of the models listed on the title page. Earlier model configurations may differ from the information given. Carefree of Colorado reserves the right to cancel, change, alter or add any parts and assemblies, described in this manual, without prior notice.

Carefree of Colorado agrees to allow the reproduction of this document for use with Carefree of Colorado products only. Any other reproduction or translation of this document in whole or part is strictly prohibited without prior written approval from Carefree of Colorado.

## SAFETY INFORMATION



**This is the safety alert symbol. It is used to alert individuals to potential personal injury hazards. Obey all safety messages that follow this symbol to avoid possible personal injury or death.**



**Indicates a hazardous situation, which if not avoided, could result in death or serious bodily injury.**



**Indicates a hazardous situation, which if not avoided, may result in minor or moderate bodily injury.**



**Indicates a situation that may result in equipment-related damage.**

### General Safety:



**This product can expose you to chemicals including Di-isodecyl phthalate (DIDP), Vinyl Chloride and Formaldehyde, which are known to the state of California to cause cancer or birth defects or other reproductive harm. For more information visit**

**[www.P65warnings.ca.gov](http://www.P65warnings.ca.gov)**



**Shock Hazard. Always disconnect battery or power source before working on or around the electrical system.**



**Always wear appropriate safety equipment (i.e. goggles).**



**Always use appropriate lifting devices and/or helpers when lifting or holding heavy objects.**



**When using fasteners, do not over tighten. Soft materials such as fiberglass and aluminum can be "stripped out" and lose the ability to grip and hold.**

## PRODUCT OVERVIEW

The Freedom Awnings are state of the art lateral arm awnings. When retracted, the housing provides protection against the elements while the streamlined styling blends in with the coach sidewall. The full tension canopy fabric allows the awning to be partially or fully extended for best shade coverage.

Each unit is equipped with lateral support arms. No vertical arms interfere with coach sidewalls, custom graphics or equipment that may be mounted on the sidewalls.

### Freedom Awning Specifications:

- Fully retractable and self-storing;
- Available as manual or motorized;
- The sealed awning motor operates on standard 12VDC (range 10VDC to 14VDC);
- Case and frame are constructed of high-strength aluminum extrusions protected with a polyester paint finish;
- Stainless steel fasteners and hardware.

### SPECIFICATIONS

Widths:	centimeters	200	220	244	257	300	350	400	450	500
	inches	79	87	96	101	118	138	157	177	197
Extension:		60" (152cm)		80" (200cm)		98" (250cm)				

### LEADING EDGE POSITION ACTUATION AND CONTROL

Power:	Lateral Arm Spring	Minimum Tension	Open
Position Control:	Motorized:	Roll Out/In Controlled by Electrical Motor	
	Manual:	Roll Out/In Controlled by Manual Crank	Crank Ratio 2.7 : 1

### MOTOR SPECIFICATIONS

Motor Type:	Tubular		
Power:	12VDC	Minimum: 10VDC	Output: 30 Watts
	Nominal Current: 2.5Amps		Max Current: 14Amps (stall @ min voltage)
Power Source:	Motor and controls are routed and hardwired into the vehicle's 12V system		
Torque	Continuous: 6Nm/4.5 ft-lbs.		Tightening: 18Nm/13.2 ft-lbs.
Speed	24 rpm		

### COLORS AVAILABLE

Case	Satin, White or Black
Fabric: <sup>1</sup>	Vinyl

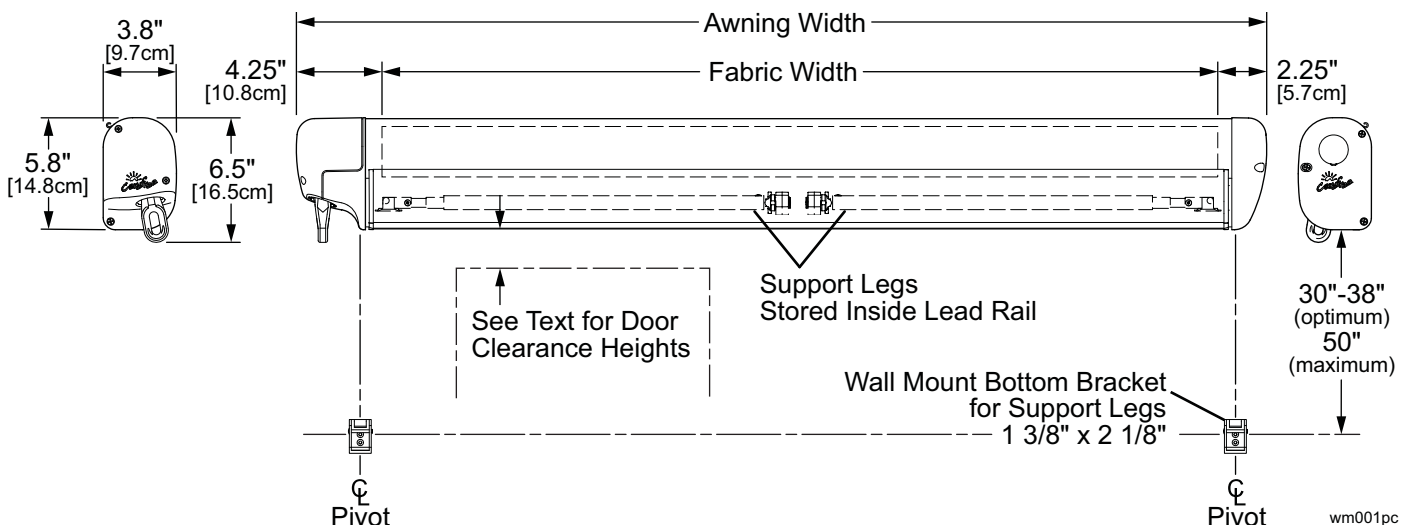

COMPONENT CHECKLIST

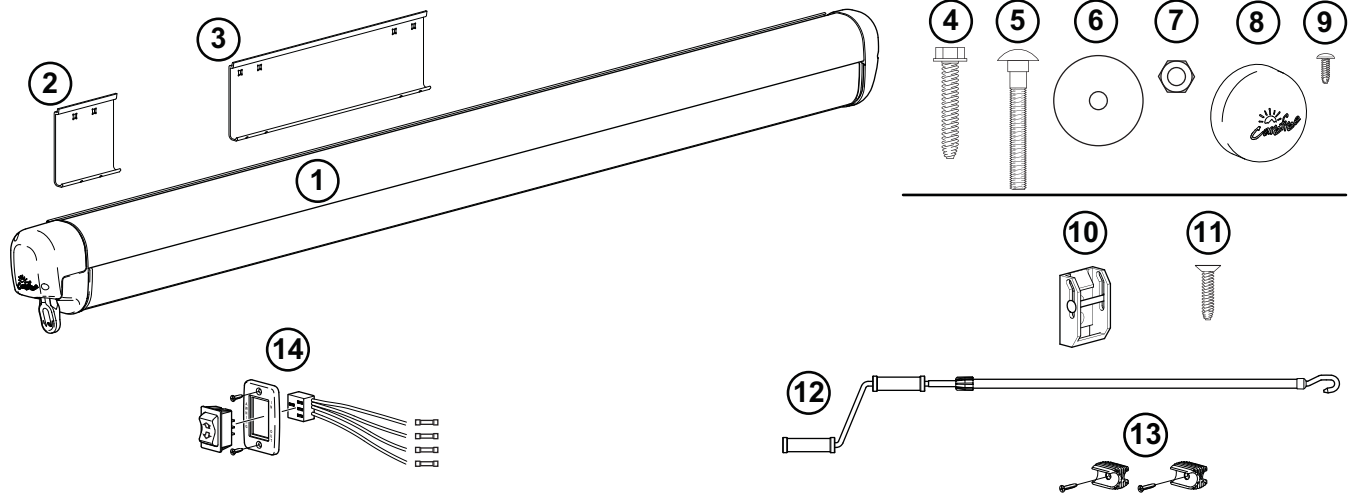

WM003

<input checked="" type="checkbox"/>	ITEM	DESCRIPTION		QTY	NOTE
<input type="checkbox"/>	1	Awning Assembly		1	1
<b>HARDWARE KITS</b> (application depending on Awning Length, see note 2)				<b>A</b>	<b>B</b>
<input type="checkbox"/>	2	Mounting Plate	12cm [4 3/4"]	3	2
<input type="checkbox"/>	3	Mounting Plate	40 cm [15.75"]	-	2
<input type="checkbox"/>	4	Screw, Lag	#14 x 1 1/2"	3	3
<input type="checkbox"/>	5	Carriage Screw	M6-1 x 50mm	6	12
<input type="checkbox"/>	6	Fender Washer		6	12
<input type="checkbox"/>	7	Nut, Nylock	M6	6	12
<input type="checkbox"/>	8	Bolt Cover		6	12
<input type="checkbox"/>	9	Screw, Square Drive Pan Head	#6 x 3/8"	6	8
<input type="checkbox"/>	10	Bottom Bracket		2	
<input type="checkbox"/>	11	Screw, Flat Head	#10 x 3/4"	4	
<input type="checkbox"/>	12	Crank Handle, "Hook"	Used with Manual Crank Only	1	3
<input type="checkbox"/>	13	Clip, Crank Handle	Used with Manual Crank Only	2	3
<input type="checkbox"/>	14	Switch Kit	Used with Motorized Only	1	4,5

- Notes:
1. Awning configuration is specified at time of order, including awning length, fabric, color etc. Check awning assembly against original purchase order.
  2. Hardware Kits are based on awning length:  
 A = 4m or shorter                      B = 4.5m and 5.0m
  3. Crank Handle (item 12) and clip (item 13) used with manual crank version only.
  4. Switch kit (Item 14) used with motorized version only. Not used with the BT12 Wireless Awning Control System.
  5. OEM's may choose to furnish the control switch. The switch must be a DC polarity reversing switch with dynamic brake.

## INSTALLATION

Two standard methods are available to mount the Freedom awning. The awning may be mounted using a set of mounting plates that attaches to the vehicle wall (refer to page 3) If using adaptor brackets, follow the instructions included with bracket kit then proceed with "Mounting the Awning" on page 4. The awning may also be mounted using an existing awning rail.

### Prior to mounting the awning:

- Review both mounting methods to determine the best mounting method for the particular application. The mounting brackets require access to the inside of the mounting surface.
- If there is an awning rail installed, check that the awning rail runs the full length of the awning. The awning rail must be extremely straight to accommodate the awning mount. The rail must be attached to structural components for stability.
- Ensure that the awning will not interfere with light fixtures, exhaust vents, openings, etc.

### ATTACHING THE MOUNTING PLATES

1. Determine the optimum positioning of the awning.
  - 1.1. The centerline of the awning fabric is offset from the centerline of the awning assembly. To align the center of the fabric, use the back plate of the awning assembly for measurements.
  - 1.2. The bottom of the mounting plates should be 28cm [11"] above any openings or frames to avoid interference when the awning is installed.
 

**NOTE:** Height is based on clearance over a 76cm [30"] door extension. The mounting height will vary 1.9cm [.75"] for every 5cm [2"] change in extension. For longer extensions, add the calculated difference. For shorter extensions, subtract the difference.

Dimensions are based on the lowest pitch with no lift from the vertical support legs.
  - 1.3. Measure each end of the awning position from the ground so that the mounted awning is parallel to the ground.
2. Mark the position with a chalk line.
3. Determine the correct plate pattern then use the plates as a template and drill 8mm [5/16"] holes through the vehicle wall to match the plates.

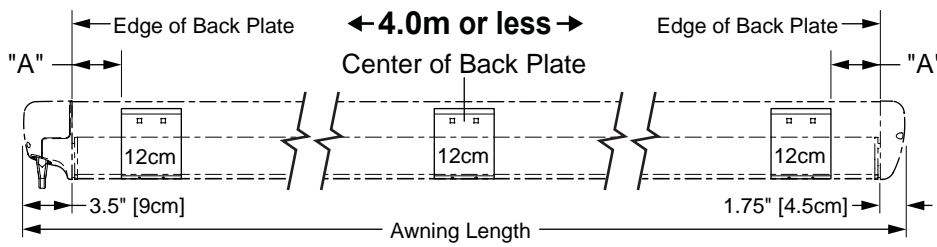

Awning	"A"	
2.0m	1.5"	[3.8cm]
2.2m	4.25"	[10.8cm]
2.44m	.25"	[.6cm]
2.57m	.25"	[.6cm]
3.0m	.25"	[.6cm]
3.5m	10.75"	[27cm]
4.0m	20.0"	[51cm]

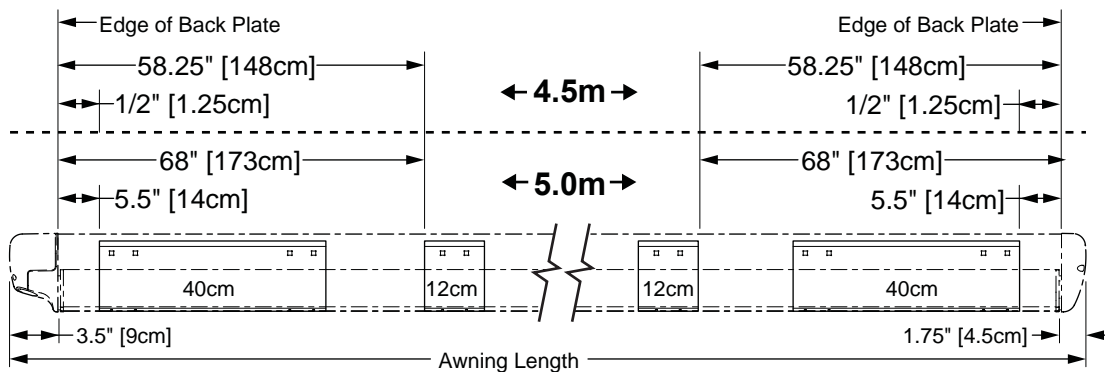

WM002

**NOTICE** For proper operation of the awning, the brackets must be placed under the arm knuckles. If it is necessary to position the brackets differently than shown on the previous page, use the knuckle positions shown.

Awning		
2.0m	4.0"	10 cm
2.2m	6.75"	17 cm
2.44m	1.5"	3.8 cm
2.57m	3.0"	8 cm
3.0m	3.0"	8 cm
3.5m	13.25"	33.5 cm
4.0m	22.5"	57.5 cm
4.5m	4.5"	11.5 cm
5.0m	14.5"	37 cm

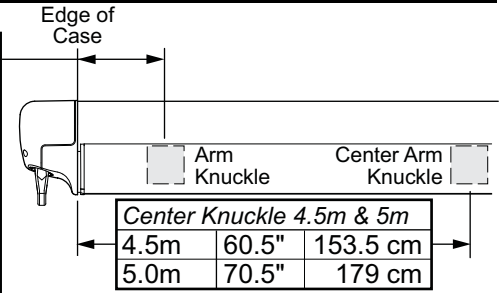

Typical Both Sides

WM045

4. Attach the plates using the supplied M6-1 x 50mm carriage bolts, fender washers, nuts and bolt covers.

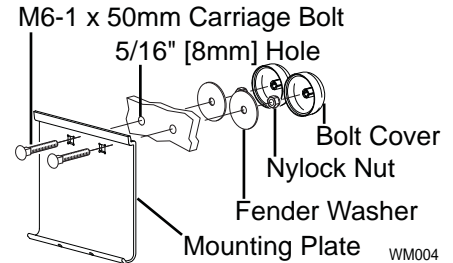

WM004

5. For motorized awnings only:

5.1. The motor wire comes out of the back of the motor end cap. Use the dimensions shown to locate the hole into the vehicle.

5.2. The hole location can be located in the areas shown to avoid interior framing, cabinets and electrical components that could be damaged or interfere with the hole location.

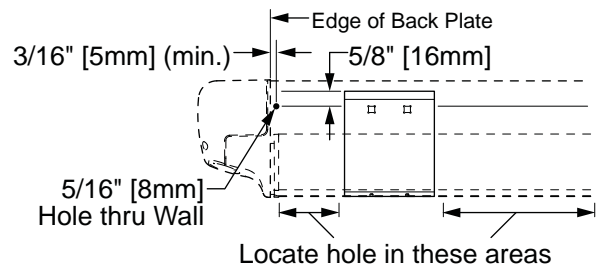

WM007

5.3. Ensure that the motor wires are accessible after routing. There is 70" [180cm] of wire furnished with the motor. If the final routing to the switch location is greater than the supplied wire from the motor, the installer must splice additional 18awg wire to the motor wires. Wire and splices are furnished by the installer.

5.4. Drill an 5/16" [8mm] hole through the outer vehicle wall.

This is a preliminary step, the wire and switch installation are completed after the awning is secured.

*Mounting the Awning*

1. Set the awning into the hooks of the mounting plates.

For motorized awnings: Route the motor wires through the hole drilled previously while lifting the awning into position.

*Tip: If the wire is routed along the back of the case, use small pieces of tape to hold the wire in place while lifting the awning.*

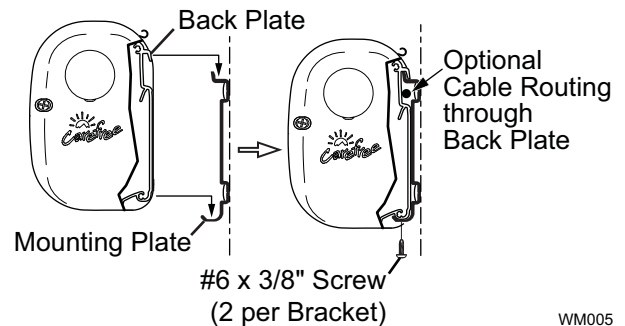

WM005

2. Adjust the position of the awning horizontally as required.

3. Attach the awning case to the mounting plates using two (2) self-tapping #6 x 3/8" screws for each bracket.

*Mounting to a Roof Rack*

Follow the standard mounting instructions. Secure the awning to the mounting brackets with three (3) #10 x 1/2" self-drilling screws. The screws must be placed in the areas shown and go through the case and into the mounting plates.

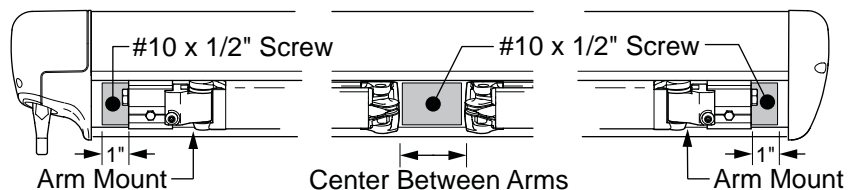

WM048

## INSTALLATION USING AN AWNING RAIL

The awning may be mounted using an existing awning rail. Awning rails are not furnished with the awning.

1. Determine the optimum positioning of the awning.
  6. When installed, the bottom of the awning case is 13.3cm [5 1/4"] from the centerline of the awning rail. The rail must be mounted a minimum of 41.3cm [16.25"] above openings to avoid interference.

**NOTE: Height dimension is based on clearance over a 76cm [30"] door extension. The mounting height will vary 1.9cm [.75"] for every 5cm [2"] change in extension. For longer extensions, add the calculated difference. For shorter extensions, subtract the difference.**

7. The centerline of the awning fabric is offset from the centerline of the awning assembly. To align the center of the fabric, use the back plate of the awning assembly for measurements.

- 7.1. Lightly spray the inside track of the awning rail with a silicone lubricant.

- 7.2. Using a minimum of two people, lift the awning up and tilt as shown.

- 7.3. Hook the mounting rail into the awning rail and roll down.

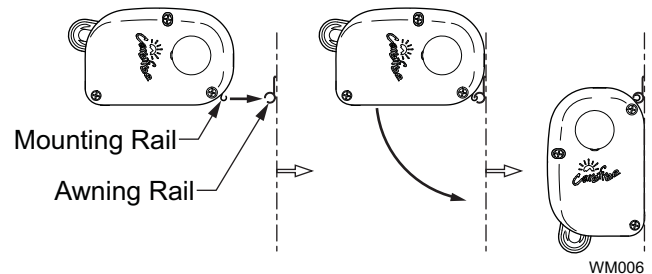

- 7.4. Adjust the position of the awning horizontally as required. It may be necessary to lift the awning so that it will slide in the awning rail.

- 7.5. For the motorized awning only:

- Lift the awning upward slightly. On the coach wall, mark the location of where the motor wires exit the awning case.
- Measure and drill one 8mm hole through the outer wall at the mark.

**NOTES: Adjust the location as required. Measure to avoid any interior framing, cabinets, electrical components etc. that could be damaged or interfere with the hole location.**

**Ensure that the motor cables are accessible after routing in the next step.**

**This is a preliminary step, the wire and switch installation are completed after the awning is secured.**

- Route the motor wires through the hole and seal with silicone sealant.

10. Rotate the awning down.

11. Open the awning 14"-18" [35 - 45cm] to allow access to the back plate.

**NOTE: To open the motorized awning, momentarily connect the motor wires to a 9-14VDC drill battery or car battery. If the motor runs in the reverse direction, reverse the leads.**

12. Drill three (3) 3/16" [4.8mm] holes through the back of the case into the mounting surface and into the structure. Use care to not drill through the inner wall.

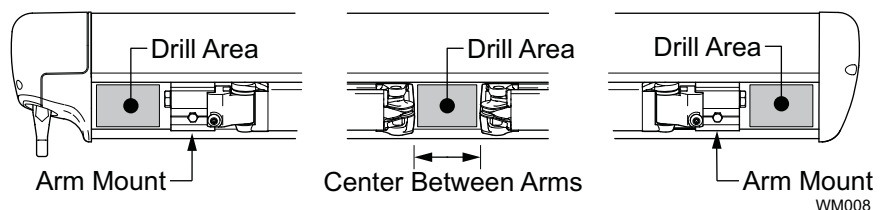

13. In the awning case, ream out the 3/16" [4.8mm] holes to 5/16" [8mm]. Do not allow the drill to extend into the wall.

### NOTICE

**The screws must be located in the open areas of the awning case as shown. The arms cannot close completely if the screw heads are underneath.**

14. Secure the awning using three (3) #14 x 1 1/2" lag screws.

### BOTTOM BRACKET INSTALLATION

The awning is equipped with vertical supports. These supports extend from the leading edge of the awning to a bracket mounted on the wall or may be used in a carport position on the ground.

1. Determine the location of the brackets:
  - Close the awning if open.
  - Measure out .5" [1.2cm] from the edge of the lead rail.
  - At the marks made previously, measure down vertically and mark the location of the brackets. The ideal location is 37"-50" [94-127 cm] below the bottom of the awning.

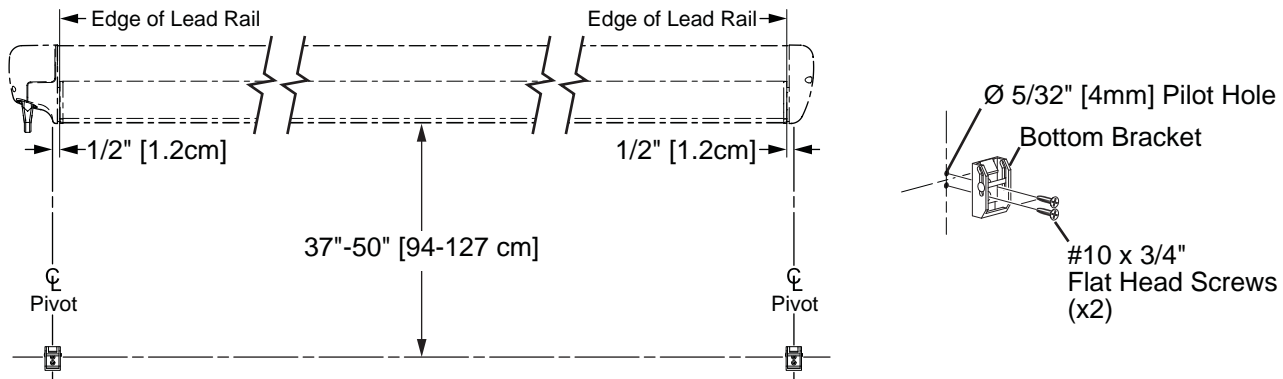

2. Center the brackets on the marks and using the bracket as a template, drill two (2) 4mm [5/32"] pilot holes.
3. Attach the brackets with two (2) #10 x 3/4": flat head screws.

### MANUAL CRANK HANDLE STORAGE CLIPS

Two clips are provided to store the manual crank handle. These may be mounted horizontally or vertically.

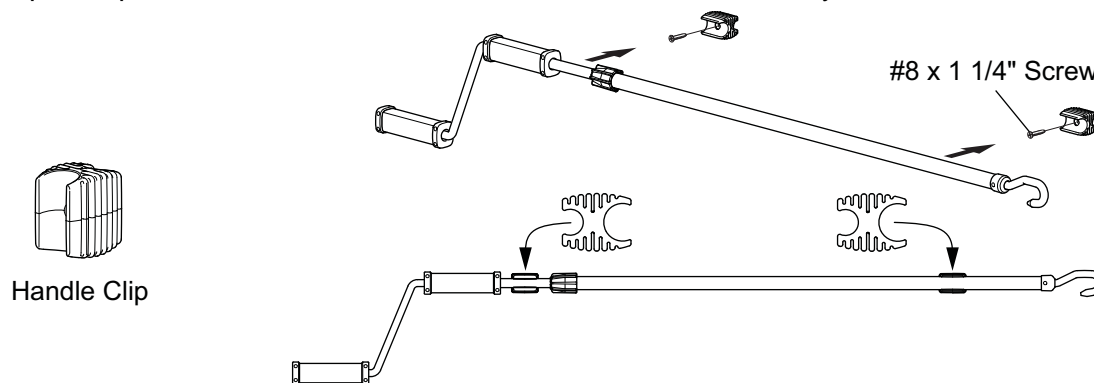

The clips are designed so that one side has a smaller diameter to fit the smaller tube of the handle. The other side has a larger diameter to fit the larger tube of the handle. The clips can be arranged as shown or the clips can be oriented so both attach to the larger tube (i.e. if the handle is fully collapsed for storage).

1. Snap the clips on to the crank handle.
2. Position the handle in the desired location and mark the locations of the clips.
3. Remove the clips from the crank handle and mount at the marks made previously. Use the #8 x 1 1/4" screws provided.

**NOTE:** The screws will go through the mounting surface approximately 1/2"; if the mounting surface material is thinner than 1/2" the screws will protrude through the opposite side.

**This completes the installation of the manual awning. For motorized awnings go to "Switch Installation" on page 6.**

**OR**

**If installing the BT12 Wireless Awning Control System use the instructions in 070029-001 "BT12 Installation Manual" for wiring and setup of controls.**



# SWITCH INSTALLATION (MOTORIZED AWNINGS ONLY)



**WARNING Shock Hazard. Always disconnect battery or power source before working on or around the electrical system.**

1. Determine the location for the switch. There is approximately 180cm [70"] of wire from the awning motor. If the distance to the switch exceeds the furnished wire, the installer must furnish 16 awg wire and butt splice to the motor wires.
2. At the switch location, cut a rectangular hole 1.25"(3.2cm) x 1.88" (4.8cm) through the mounting surface.
3. Determine the switch orientation:
  - 3.1. The wires of the connector extend from the side of the switch with 3 terminals on the back.
  - 3.2. For wire routing on the right side of the switch, orient the switch with the 3 terminals on the right.
  - 3.3. For wire routing on the left side of the switch, orient the switch with the 3 terminals on the left.
  - 3.4. Push the switch into the faceplate until the tabs on the switch "click" into place behind the faceplate. Ensure that the switch and faceplate are oriented so that the lettering is up and the wires are oriented as desired.
  - 3.5. Set switch aside.

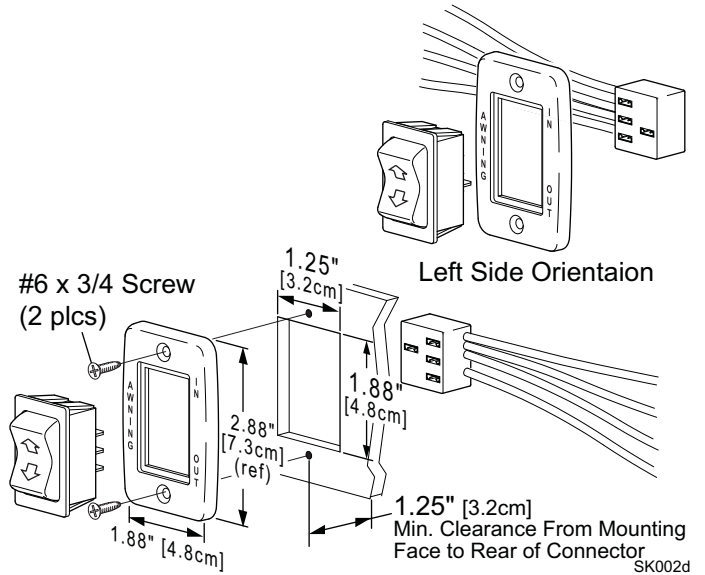

4. Route the awning motor wires through the switch hole and attach to the switch connector:

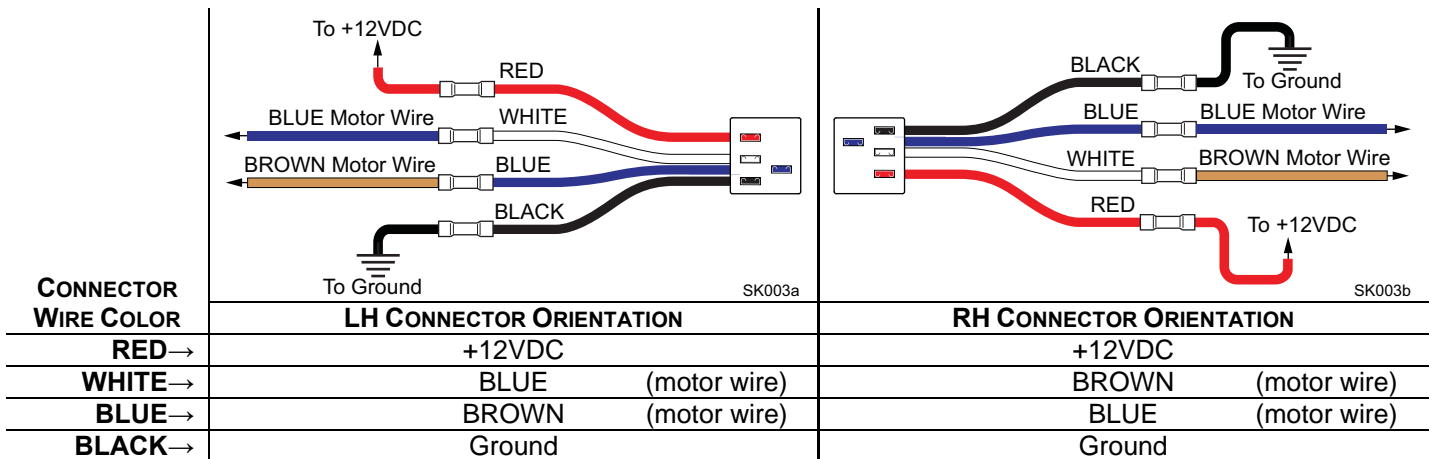

5. Run a minimum 14 awg wire from the power distribution panel (auxiliary battery circuit) or equivalent. The circuit should be protected by a 15-amp fuse.
6. Run a minimum 14 awg wire to system ground.
 

**NOTE:** If the wire run is 30 feet or longer, use 12awg wire to prevent voltage drop.
7. Route the two wires through the mounting hole. Butt splice the 12VDC wire to the RED connector wire. Butt splice the ground wire to the BLACK connector wire.
8. Attach the connector to the switch.
9. Restore power and test the switch operation.
10. If the awning operates opposite to the switch plate markings: Shut off power; Reverse motor wires connected to the blue and white connector wires. Restore power and test.
11. Push the wires, connector and switch into the mounting hole and secure the switch plate. Use two (2) #6 x 3/4" flat head screws.

## OPTIONAL LED LIGHTING

Optional LED lighting may be mounted in the lead rail. The wiring runs along the top of the arm.

*For motorized awnings:* Route the LED wire harness with the motor cable into the vehicle.

*For manual crank awnings:* The harness routes through the end of the case. Drill a 3/16" hole into the vehicle wall as shown on page 4.

**NOTICE** The following information must be followed to avoid damage to the wiring during and after installation.

- a) The wire should be secured to the wall of the vehicle where it is exposed on the outside of the vehicle. Use a quality sealant/adhesive.
- b) Do not route the wire over sharp edges or heat sources that can damage the wires or wire insulation.
- c) Damage that is a result of improper routing may void warranty.

## SWITCH INSTALLATION

**NOTE:** Installers may choose to furnish the control switch. The installation requires that the power line (+12VDC) be attached to a dedicated 2A circuit breaker or a 2A in-line fuse must be installed between the switch and power source. For easy access, locate the fuse close to the switch.

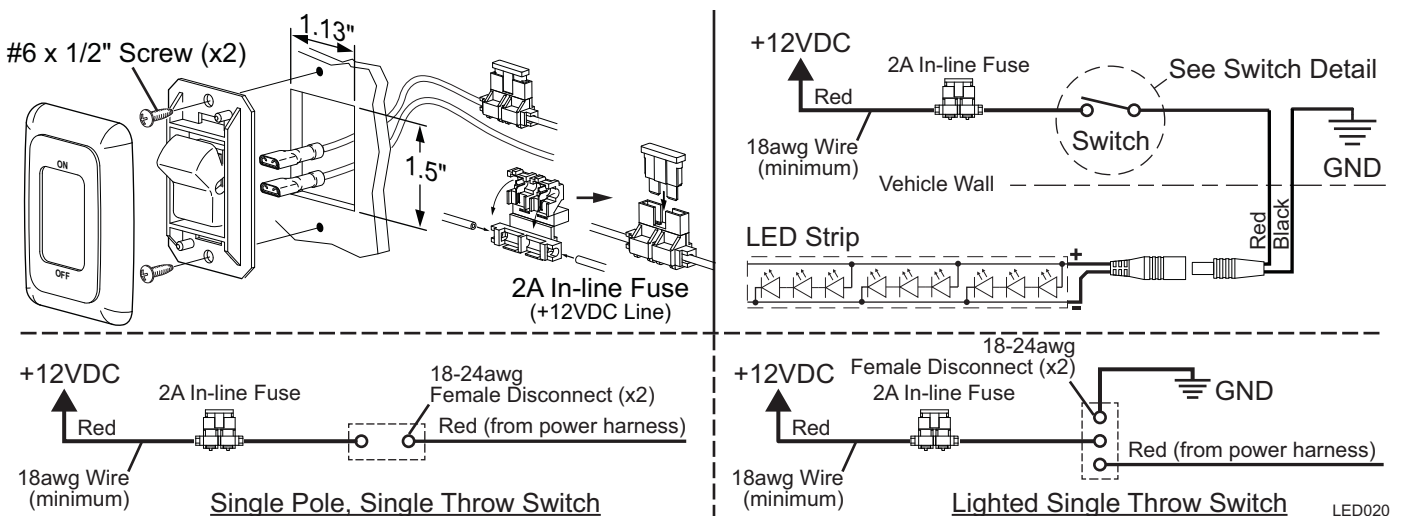

1. Determine the location of the switch.
2. At the switch location, cut a 1 1/8" x 1 1/2" hole.
3. Wire the switch as shown below. Wire terminals at the switch are .187, 18-24 awg female disconnects.
 

**NOTE:** Allow adequate slack in the 12VDC power line so that the in-line fuse (installed in step 4) can be accessed from behind the switch.
4. Install the in-line fuse:
  - 4.1. Near the switch, cut the red 12VDC power line to the switch. Do not strip the insulation.
  - 4.2. Insert a wire end into one of the wire channels until it butts up against the stop.
  - 4.3. Fold that half of the connector body over until the element contacts the wire. Use pliers to crimp the connector closed.
  - 4.4. Repeat for the second wire end.
  - 4.5. Slide the fuse into the fuse port. Ensure that the fuse is firmly seated.
5. Press the in-line fuse, wires and switch into the mounting hole. Secure the switch using two (2) #6 x 1/2" screws.
6. Snap the switch bezel over the switch frame.

## PITCH ADJUSTMENT

The Freedom WM provides minor pitch adjustment for aligning the lead rail with the case. This adjustment is only for fine-tuning the installation. It is not intended as an operational pitch adjustment.

**NOTICE** When the pitch of the awning is adjusted, it is important that the lead rail is parallel to the awning housing.

1. Open the awning to access the adjustment screw located on the arm case knuckle.
2. Have a second person lift up on the lead rail to relieve the pressure on the adjustment screw.
3. Using a 4mm allen wrench, turn the adjustment screw clockwise to raise the lead rail; turn the adjustment screw counterclockwise to lower the lead rail.
4. Repeat for the other side as necessary.

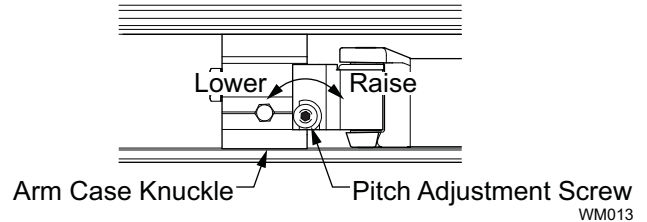

## MANUAL OVERRIDE (MOTORIZED VERSIONS ONLY)

If power to the vehicle is not available, the awning can be safely retracted using the manual override located on the idler (right) end of the case.

**NOTE:** This procedure cannot be used to extend the awning.

1. Remove the plug from the right endcap and save.
2. Insert a 3/8" socket drive extension and handle into the square drive hole inside the end cap.
3. Turn the handle counterclockwise until the awning is retracted.
4. Replace the plug.

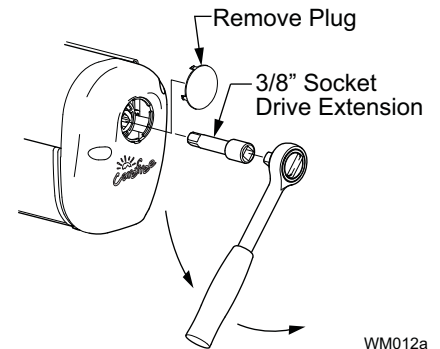

**NOTICE** After closing the awning with the manual override, the lead rail may move out from the case 1/4" -1/2". This is normal and the awning is secure for travel until power is restored or repairs are completed. Do not attempt to force the lead rail in with the override, serious damage can occur to the awning.

## SETTING THE MOTOR LIMITS

The motor limit switches are preset at the factory for best operation of the awning. The "OUT" limit switch is used to stop the motor when the awning is fully extended. The "IN" limit switch is used to stop the motor when the awning is fully retracted.

The limit switches are located inside the motor endcap.

To access the switches, remove the outer motor endcap and plug.

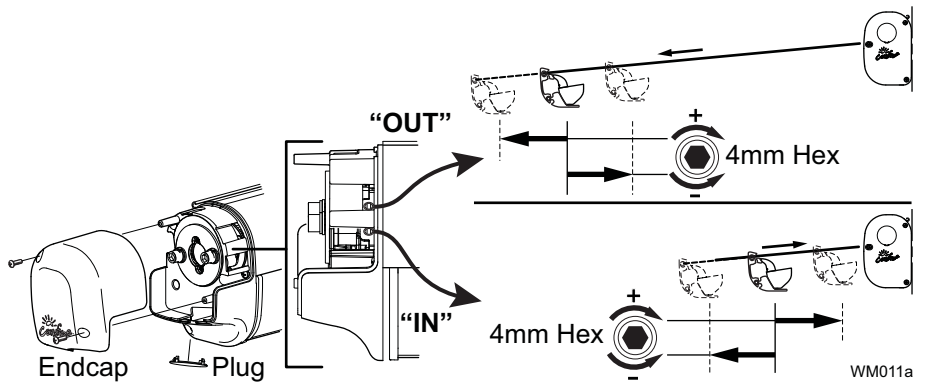

### Adjusting the OUT Limit Switch

1. Extend the awning out completely.
2. Confirm that the arms are fully extended. The motor should stop and the fabric should be tight. If the motor continues to run, the fabric will sag; or, if the motor quits before the arms are fully extended, it will be necessary to adjust the "OUT" limit switch.
 

**NOTE:** It is best to make the adjustments in increments of a single turn. 3 full turns of the screw equals approximately 2" of fabric extension.
3. If the fabric sags:
  - 3.1. Retract the awning until the fabric is tight then retract an addition 10"-12".
  - 3.2. Using a 4mm Allen wrench turn the "OUT" limit switch COUNTERCLOCKWISE to reduce the time the motor runs.
  - 3.3. Extend to confirm that the adjustment is correct.
  - 3.4. Repeat the procedure until the awning extends correctly.
4. If the arms do not extend completely:
  - 4.1. Retract the awning approximately 10"-12".
  - 4.2. Using a 4mm Allen wrench turn the "OUT" limit switch CLOCKWISE to increase the time the motor runs.
  - 4.3. Extend to confirm that the adjustment is correct.
  - 4.4. Repeat the procedure until the awning extends correctly.

### Adjusting the IN Limit Switch

1. Retract the awning in completely.
2. Confirm that the arms are fully retracted. The motor should stop when the awning is fully retracted. If the motor quits before the arms are fully retracted; or, if the motor continues to run after the awning is closed, it will be necessary to adjust the "IN" limit switch.
 

**NOTE:** It is best to make the adjustments in increments of a single turn. 3 full turns of the screw equals approximately 2" of fabric extension.
3. If the motor stops before the awning is fully retracted:
  - 3.1. Extend the awning 10"-12".
  - 3.2. Turn the "IN" limit switch CLOCKWISE to increase the time the motor runs.
  - 3.3. Retract the awning to confirm that the adjustment is correct.
  - 3.4. Repeat the procedure until the awning retracts correctly.
4. If the motor continues to run:
  - 4.1. Extend the awning approximately 10"-12".
  - 4.2. Turn the "IN" limit switch COUNTERCLOCKWISE to decrease the time the motor runs.
  - 4.3. Extend and retract to confirm that the adjustment is correct.
  - 4.4. Repeat the procedure until the awning extends correctly.