



RV

MOTORIZED VARIABLE PITCH PATIO AWNING



Read this manual before servicing or using this product. Failure to follow the instructions and safety precautions in this manual can result in personal injury and/or cause the product to not operate properly.

For LED replacement parts and service procedures refer to 052584-301 “LED Service Manual for Vertical Arms” available on-line at www.carefreeofcolorado.com



TABLE OF CONTENTS

Specifications 1

Canopy Replacement..... 2

Motor and/or Gear Replacement..... 4

 For Awnings Fully or Partially Extended 4

 For Awnings Fully Retracted 6

Replacing the Gas Shock 8

Pitch Adjust Assembly and Parts Replacement..... 10

 Replacing the Pitch Adjustment Pins.....10

 Replacing the Arm Rollers or Pitch Adjust Assembly10

Wiring Diagram..... 11

Standard Maintenance 12

 Fabric Care12

 Arm Care12

 Emergency Override.....13

Part Number Listing 14

 Part Number/Serial Number Location.....14

 Illustrated Parts List.....14

PROPRIETARY STATEMENT

The Compass Patio Awning is a product of Carefree of Colorado, located in Broomfield, Colorado, USA. The information contained in or disclosed in this document is considered proprietary to Carefree of Colorado. Every effort has been made to ensure that the information presented in the document is accurate and complete. However, Carefree of Colorado assumes no liability for errors or for any damages that result from the use of this document.

The information contained in this manual pertains to the current configuration of the models listed on the title page. Earlier model configurations may differ from the information given. Carefree of Colorado reserves the right to cancel, change, alter or add any parts and assemblies described in this manual, without prior notice.

Carefree of Colorado agrees to allow the reproduction of this document for use with Carefree of Colorado products only. Any other reproduction or translation of this document in whole or part is strictly prohibited without prior written approval from Carefree of Colorado.

SAFETY INFORMATION



This is the safety alert symbol. It is used to alert individuals to potential personal injury hazards. Obey all safety messages that follow this symbol to avoid possible personal injury or death.



Indicates a hazardous situation, which if not avoided, could result in death or serious bodily injury.



Indicates a hazardous situation, which if not avoided, may result in minor or moderate bodily injury.



Indicates a situation that may result in equipment-related damage.

General Safety:



This product can expose you to chemicals including Di-isodecyl phthalate (DIDP), Vinyl Chloride and Formaldehyde, which are known to the state of California to cause cancer or birth defects or other reproductive harm. For more information visit www.P65warnings.ca.gov



Shock Hazard. Always disconnect battery or power source before working on or around the electrical system.



Always wear appropriate safety equipment (i.e. goggles).



Always use appropriate lifting devices and/or helpers when lifting or holding heavy objects.



When using fasteners, do not over tighten. Soft materials such as fiberglass and aluminum can be "stripped out" and lose the ability to grip and hold.

SPECIFICATIONS

The adjustable pitch Compass provides motorized awning comfort with Carefree's standards for looks, strength and dependability with a successful blend of style, quality and economy.

The variable pitch offers 6 settings from flat (3°) to steep (16°).

The awning roller tube and arms are made from light weight, no-rust aluminum. The awning fabric is heavy weight vinyl.

White and RGB LED lighting is available with the strip mounted in the roller tube or at the awning rail.

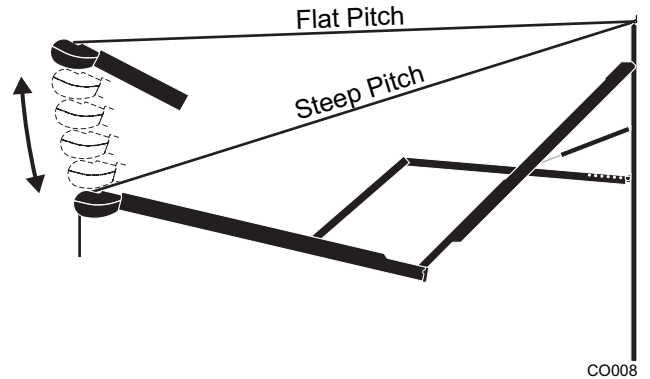

CO008

MAXIMUM EXTENSION:	90 inches	MAXIMUM LENGTH:	20 feet
PITCH:	FLAT	3°	DROP:
	STEEP	16°	
Angle is Canopy vs horizontal		Measurement is from centerline of Awning Rail to centerline of roller tube	
MOTOR:	Power: 10VDC–14VDC	Circuit Rating: 15 amp	motor mounted in arm
POWER SOURCE:	Motor and controls are routed and hardwired into the vehicle's 12V system		
EXTEND ACTUATION:	Gas Shock		
POSITION CONTROL:	Motorized roll out/in		
CONTROLLER:	3 position, momentary ON, center OFF Switch		
COLOR:	Frame:	White, Black	
	Canopy:	Vinyl with Weatherguard or FLXguard. Refer to sales literature for options.	
LED	LED strip mounted in roller tube or at the awning rail		
	Power:	1A, 12VDC	
	Control	<u>White:</u> Single pole, single throw switch (SR0101) <i>Note: The Switch kit is ordered separately. Kit includes in-line fuse holder and 2A spade type fuse. For an installer furnished control switch, see note under "Switch Installation".</i>	
		<u>RGB</u> IR (Infrared) Controller with sensor and remote.	

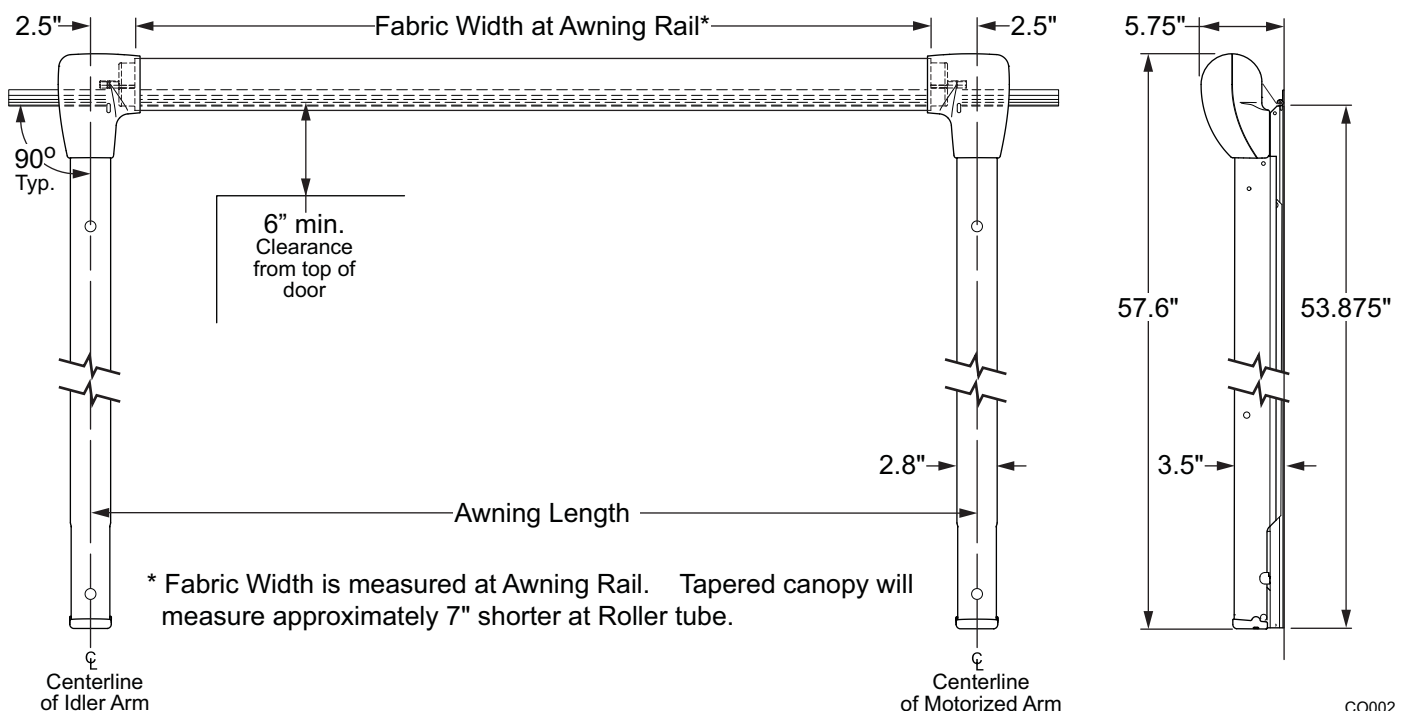

CO002

CANOPY REPLACEMENT

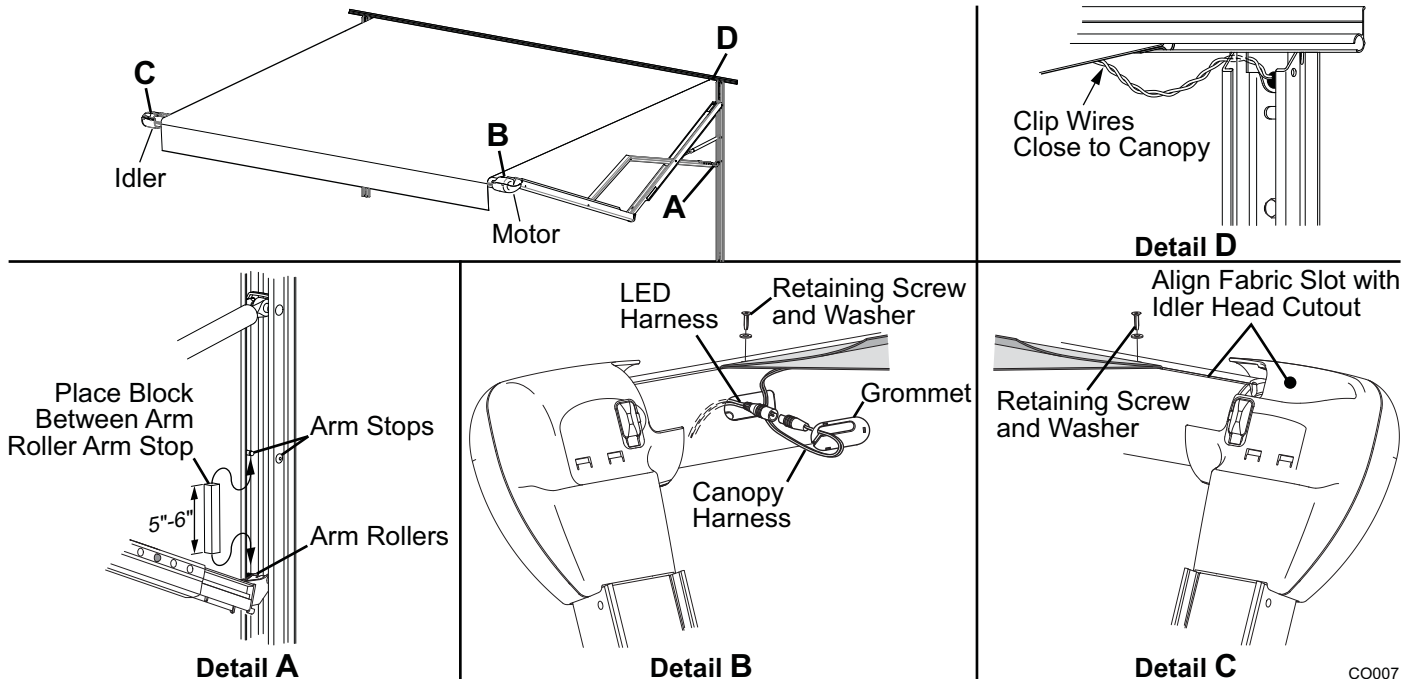

1. Remove the canopy retaining screws in the awning rail.
2. Partially extend the awning.
3. Place stop blocks between the arm rollers and arm stops on both arms. Blocks should be 5"-6" in length.
4. Extend the awning. The arms will stop with the stop blocks in place. Check that the blocks are firmly seated between the rollers and arm stops.
5. Continue to unroll the canopy from the roller tube. Continue until the fabric slot is aligned with the cutout on the back of the idler head.
6. Disconnect power to the awning.
7. For awnings with LEDs in the roller tube:
 - 7.1. On the motor side, remove the split grommet from the roller tube.
 - 7.2. Carefully pull the wires and connectors out of the roller tube. Disconnect the connectors.
 - 7.3. Tape or clamp the LED harness connector outside the roller tube to prevent it from falling back into the roller tube. This can be done with a paper clip or similar device that will not damage the wires.
 - 7.4. At the awning rail, clip the harness close to the canopy. Clamp the harness going into the vehicle to prevent it from falling in the wall.
8. For awnings with LEDs at the awning rail: Disconnect the LED strip from the harness for white LEDs or from the controller for RGB applications.
9. Remove the fabric retaining screws in the roller tube.
10. Slide the fabric out of the awning rail and roller tube.
 - 10.1. For canopies with LEDs at the awning rail: The LED rail adaptor is attached to the canopy and will slide out with the canopy.
11. Clean and deburr the roller tube slots and awning rail as required. If not previously done, spread open the awning rail track to facilitate inserting the new fabric.

Tip: Lightly spraying the slots with a dry silicone lubricant will help the fabric slide into the slot without staining the material.

NOTE: While the awning fabric is fairly robust, care must be taken not to snag it on the awning rail.

12. Slide the new canopy into the roller tube and awning rail and center in the roller tube.
13. Secure the fabric to the roller tube with the retaining screws removed previously. Screws are placed under the valance and through the reinforcements on the canopy.
14. Restore power.
15. Retract the awning and remove the blocks between the arm stop and arm rollers.
16. Check that the canopy is rolling up squarely onto the roller tube. Adjust as necessary.

17. Place one (1) #6 x 3/8" screw through the awning rail, fabric and polyrod approximately 1" in from the fabric edge. Pull the fabric taut and place a second retaining screw on the opposite side.

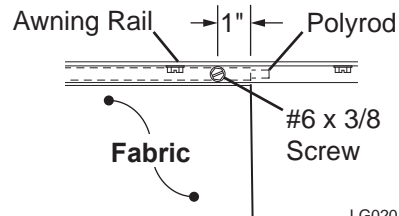

18. For awnings with LEDs in the roller tube:

- 18.1. Connect the canopy harness connector and LED connector. Then carefully push the connectors into the roller tube.
 - 18.2. Place the split grommet over the canopy harness and press the grommet into the hole of the roller tube.
 - 18.3. At the vehicle wall, route the new canopy harness through the wall to the switch.
Tip: Tie the new harness to the old harness that was cut previously. Use the old harness to pull the new harness through the wall to the desired location.
 - 18.4. At the vehicle wall, provide a 3" loop of harness between the canopy and wall. Seal the wall entrance hole and harness with a quality silicone sealant.
 - 18.5. Connect the new harness to the switch. Two (2) .187, 18-24 awg female disconnects are provided if connecting to a switch.
 - 18.6. Alternate method: At the wall, splice the new harness to the existing harness using 24 awg butt connectors. Push the connectors into the vehicle wall. Seal the wall entrance hole and wires with a quality silicone sealant.
NOTE: Be sure to allow enough harness from the canopy to provide a 3" loop of harness and adequate length for the connectors to be pushed inside the wall before sealing the hole and harness with a quality silicone sealant.
19. For canopies with LEDs at the awning rail: Connect the LED strip to the harness for white LEDs or to the controller for RGB applications.

MOTOR AND/OR GEAR REPLACEMENT

CAUTION The arms are under tension from the gas shocks. When the motor is removed the roller tube will be able to free spin and **both** arms will extend from the gas shock tension. It will be necessary to have at least one other person holding the roller tube and idler arm.

For Awnings Fully or Partially Extended

1. Disconnect power to the awning.
2. Remove the front cover on the motor side. To remove: Press in on both sides of the rear cover in the area shown. Rotate the cover up and off.
3. Disconnect the motor wires from the motor cable.
4. On the back of the rear cover open the access cover and pull out the roller tube retaining clip until it disengages from the roller tube. The clip will "latch" in the detach position and can be left in the cover.
5. Pull the roller tube from the motor head.
6. Allow the motor arm to slowly extend out to its maximum extension.
7. While firmly holding the idler arm and roller tube, allow the awning to slowly extend out to the maximum extension of the canopy. Use a scaffold or similar device to support the motor end of roller tube.

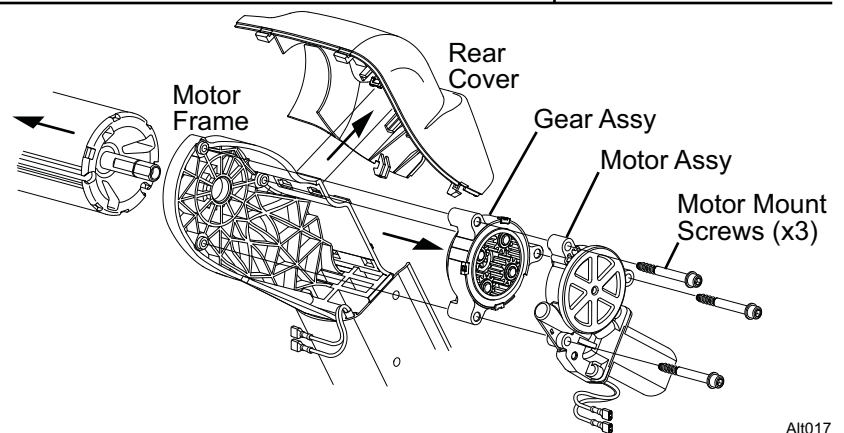
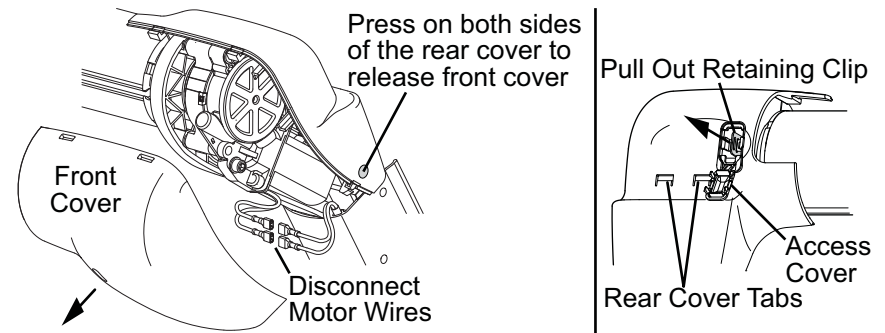

AI1017

NOTICE Do not allow the roller tube to drop toward the ground. The twisting motion can cause serious damage to the idler arm.

8. Using a flat blade screw driver, press and release the two (2) rear cover tabs. Lift the rear cover off of the motor frame.
9. Remove the three (3) motor mount screws, motor and gear box from the motor frame. Set parts aside.

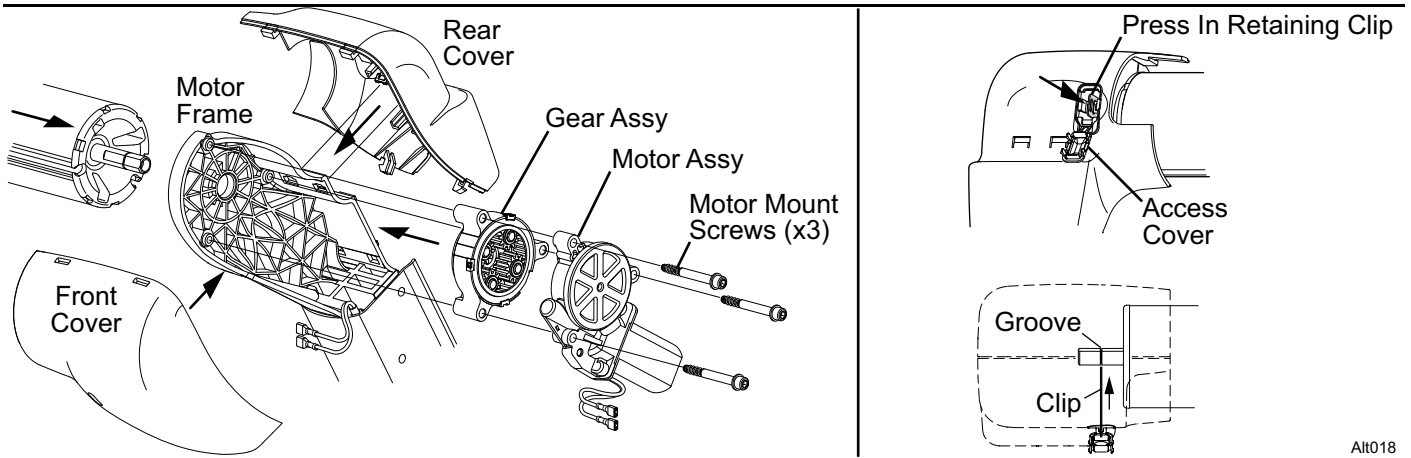

Alt018

10. Attach the new gear box and motor to the frame using the three (3) motor mount screws removed previously.
11. Snap the rear cover onto the motor frame.
12. Align the roller tube and insert the shaft into the head. It may be necessary to rotate the roller tube to align the flats of the shaft with the opening.
13. Ensure that the roller tube is fully inserted into the head. With the roller tube shaft FULLY INSERTED, press the retaining clip onto the shaft. The clip goes in only when the shaft is fully inserted. Press the clip until it is firmly seated in the groove of the roller tube shaft.
14. Attach the motor wires to the arm cable. Ensure that the wire colors match.
15. Snap the front cover onto the rear cover. Hang the cover on the top and swing down until it clicks.
16. Restore power and test.

For Awnings Fully Retracted

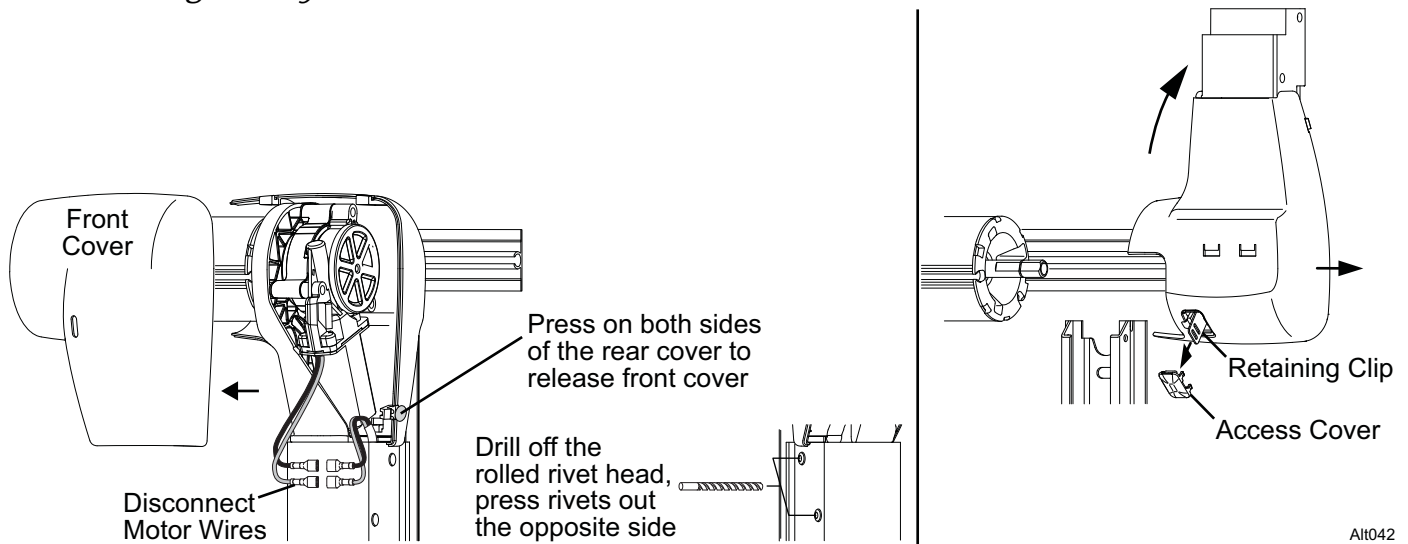

Alt042

1. Disconnect power to the awning.
2. Remove the front cover on the motor side. To remove: Press in on both sides of the rear cover in the area shown. Rotate the cover up and off.
3. Disconnect the motor wires from the motor cable in the arm.
4. Drill off the rolled rivet heads and press out the two rivets. Use care to not enlarge the holes in the parts.
5. Slowly extend the motor arm out from the wall.
6. Rotate the motor head and roller tube up to access the rear motor cover.
7. On the rear cover open the access cover and pull out the roller tube retaining clip until it disengages from the roller tube. The clip will "latch" in the detach position and can be left in the rear cover.
8. Pull the motor head off of the roller tube
9. While firmly holding the idler arm and roller tube, allow the awning to slowly extend out to the maximum extension of the canopy. Use a scaffold or similar device to support the roller tube.

NOTICE Do not allow the roller tube to drop toward the ground. The twisting motion can cause serious damage to the idler arm.

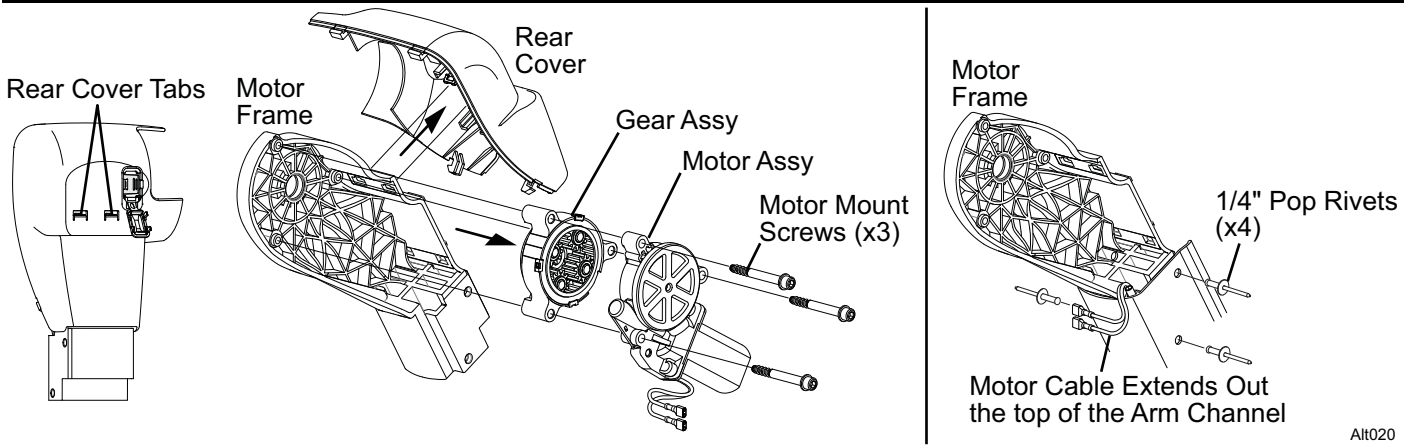

Alt020

10. Using a flat blade screw driver, press and release the two (2) rear cover tabs. Lift the rear cover off the motor frame.
11. Remove the three (3) motor mount screws, motor and gear box from the motor frame. Set parts aside.
12. Position the motor frame in the arm channel. Ensure that the motor cable is extending out of the channel.
13. Attach the motor frame to the arm channel using four (4) 1/4" pop rivets (.09-.25 grip range).

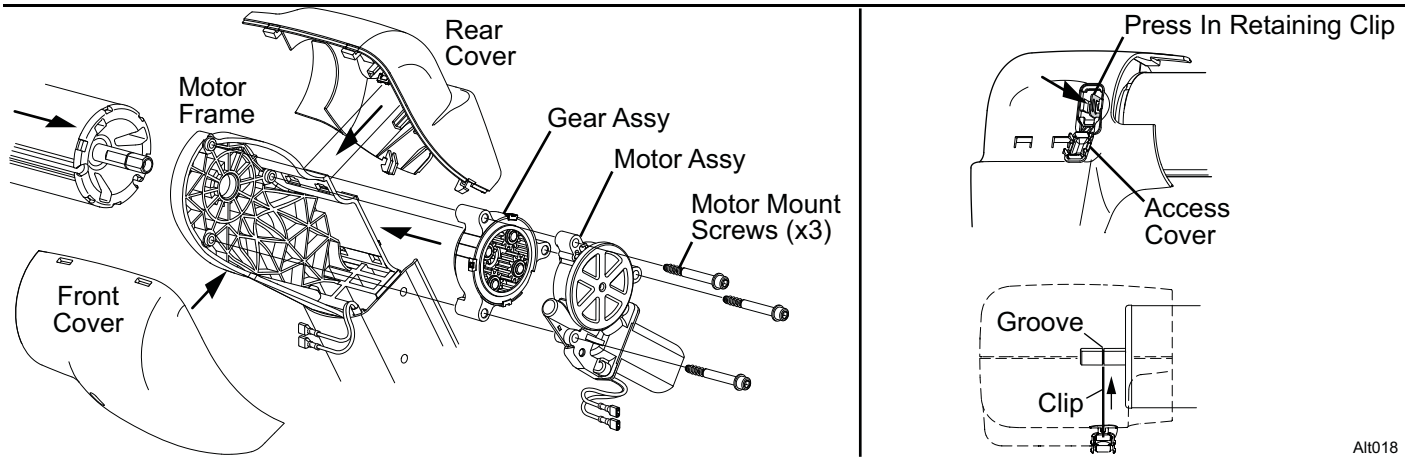

Alt018

14. Attach the gear box and motor to the frame using the three (3) motor mount screws removed previously.
15. Snap the rear cover onto the motor frame.
16. Align the roller tube and insert the shaft into the head. It may be necessary to rotate the roller tube to align the flats of the shaft with the opening.
17. Ensure that the roller tube is fully inserted into the head. With the roller tube shaft FULLY INSERTED, press the retaining clip onto the shaft. The clip goes in only when the shaft is fully inserted. Press the clip until it is firmly seated in the groove of the roller tube shaft.
18. Attach the motor wires to the arm cable. Ensure that the wire colors match.
19. Snap the front cover onto the rear cover. Hang the cover on the top and swing down until it clicks.
20. Restore power and test.

REPLACING THE GAS SHOCK

CAUTION The gas shock has approximately 105 lbs. of pressure in the closed position. A pressurized shock can open rapidly when removed or released and cause personal injury and property damage.

1. Open the awning.

NOTE: The arm may not open completely when the shock has lost pressure or is removed. It may be necessary to carefully pull the arm out and away from the vehicle to open the awning.

2. Drill out the arms stops from the rear channel. Use caution to not oversize the holes.
3. On the rear cover, open the access cover and pull the retaining clip out to release the roller tube.
4. Separate the roller tube and end cap. It will be necessary to hold the roller tube and motor arm. Allow the arm to extend out.
5. Support the roller tube and arm.

NOTICE Do not allow the roller tube to drop toward the ground. The twisting motion can cause serious damage to the other arm.

6. Unscrew the shock barrel from the clevis in the mounting channel.

Tip: Wearing a pair of rubber gloves will aid in gripping the surfaces of the shock.

7. Unscrew the shaft from the clevis in the arm joint. Set old shock aside.

NOTE: It may be necessary to use vice grips or pliers on the old shock to unscrew the shock from the clevis. DO NOT use vice grips or pliers on the new shock. Damage to the surface of the shaft or damage to the barrel can cause the new shock to not work correctly.

8. Unpack the new shock and carefully allow it to extend to its maximum length.
9. Coat the threads of the shaft of the new shock with a non-permanent thread lock (i.e. loctite) then screw the rod into the clevis of the arm elbow. Hand-tighten only.
10. Lift and hold the arm up. The arm should be unfolded and extended as far as possible.
11. Coat the threads of the barrel of the new shock with a non-permanent thread lock (i.e. loctite) then screw the barrel into the clevis in the mounting channel. Hand-tighten only. It will be necessary to grip and hold the shaft while turning the barrel.

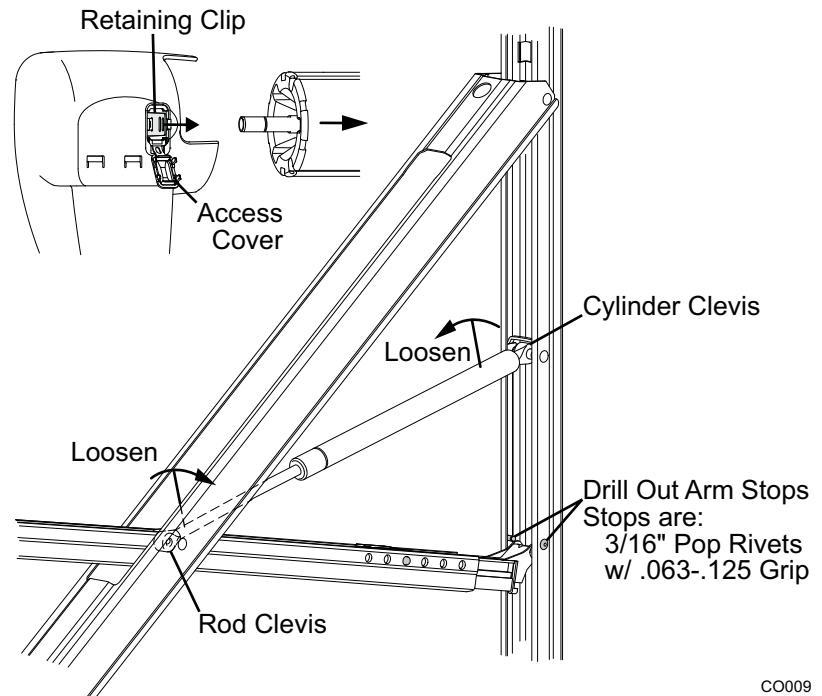

C0009

12. Attach the roller tube to the arm:

For Motor Side:

- 12.1. On the RH (motor) arm, press the roller tube shaft into hole in the motor head. It may be necessary to twist the roller tube to align the flats on the roller tube shaft with the flats in the motor head bearing.
- 12.2. With the roller tube shaft FULLY INSERTED, press the retaining clip onto the shaft. The clip goes in only when the shaft is fully inserted. Press the clip until it is firmly seated in the groove of the roller tube shaft.

NOTICE The roller tube must be fully inserted into the head for the clip to align with the groove on the shaft. The roller tube can disengage if the clip does not seat in the groove of the shaft.

For Idler Side:

- 12.3. On the LH (idler) arm, press the roller tube shaft into hole in the idler head.
 - 12.4. With the roller tube shaft fully inserted, press the retaining clip onto the shaft. Move the roller tube shaft until the clip aligns with the inner groove of the shaft. Press the clip until it is firmly seated in the groove of the shaft.
13. Partially retract the awning. It may be necessary to lightly pull down on the lower arm at the mounting channel until the rollers are past the location of the arm stops. Always pull down from the bottom of the arm to avoid pinching.
14. Install new arm stops where the old stops were removed. The stops are 3/16" pop rivets with a .063-.124" grip range.

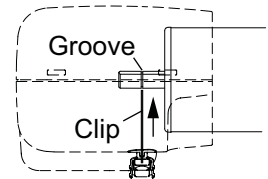
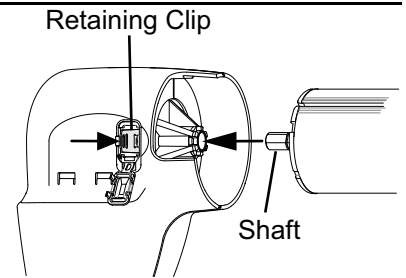

Motor Head

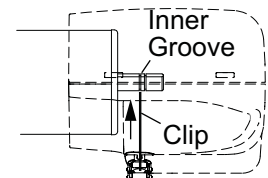
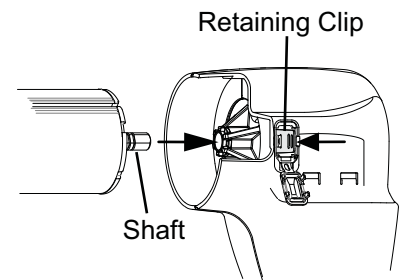

Idler Head

Alt022

PITCH ADJUST ASSEMBLY AND PARTS REPLACEMENT

This procedure describes the steps to replace the pitch adjust assembly, pitch adjustment pins and the arm rollers. The procedures are the same for the RH and LH arms.

REPLACING THE PITCH ADJUSTMENT PINS

1. Extend the awning to access the inside of the pitch adjust assembly.
2. Adjust the awning pitch to the flat (minimum) pitch.
3. Disconnect power to the awning.
4. Squeeze the old pitch adjustment pins and lift out.
5. Insert the new pitch adjustment pins. Ensure that the pins engage the holes in the pitch adjust assembly and the arm channel.

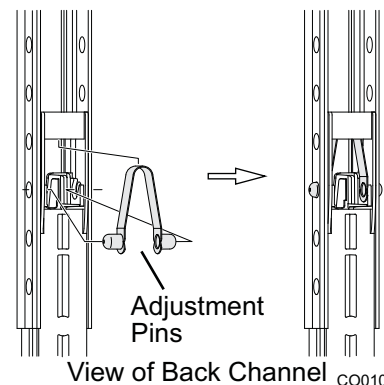

REPLACING THE ARM ROLLERS OR PITCH ADJUST ASSEMBLY

The following procedure is used to replace the arm rollers or the complete pitch adjust assembly.

NOTICE This procedure requires two people. The second person is required to hold and support the arm and roller tube during the procedure.

1. Extend the awning to access the pitch adjust assembly.
2. Disconnect power to the awning.
3. If installed, remove the optional lower wire cover.
4. Drill out the rivet stop at the bottom of the arm channel.
5. Have one person hold and lift the arm and roller tube.
6. Press in the pitch adjustment pins and slide the pitch adjust assembly out of the arm channel.
7. Slide the pitch adjustment assembly out of the bottom of the rear channel.
8. For roller replacement, remove the old rollers from the posts.
9. Slide the new rollers onto the posts of the pitch adjust assembly.

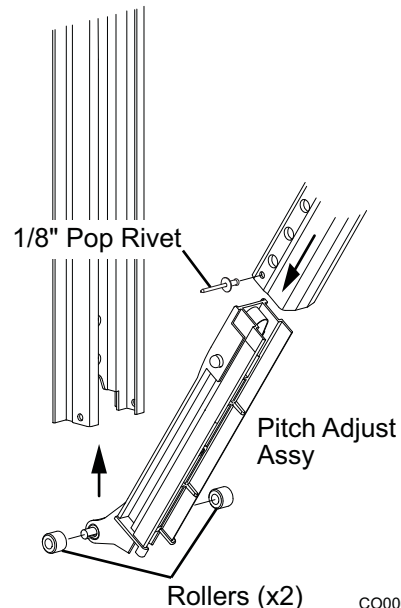
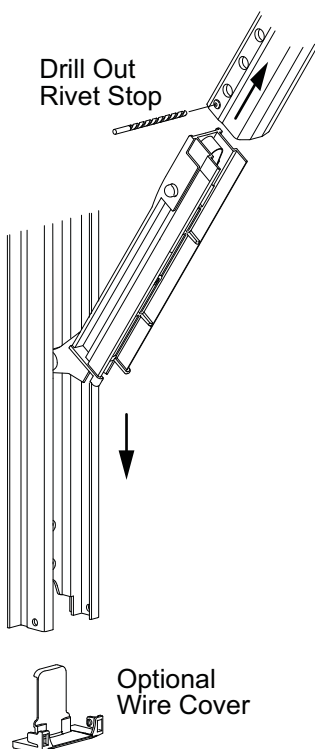

NOTE: The rollers are shipped loose with new pitch adjust assembly.

10. Slide the pitch adjust assembly and rollers into the rear channel. Note the orientation as shown.
11. Align the arm channel and pitch adjustment assembly and slide together. It will be necessary to press in the adjustment pins. Push the parts together until the pins pop out of the standard adjust holes in the channel.
12. Install a 1/8" pop rivet in the rivet stop hole that was drilled out previously.

WIRING DIAGRAMS

STANDARD – SINGLE SWITCH

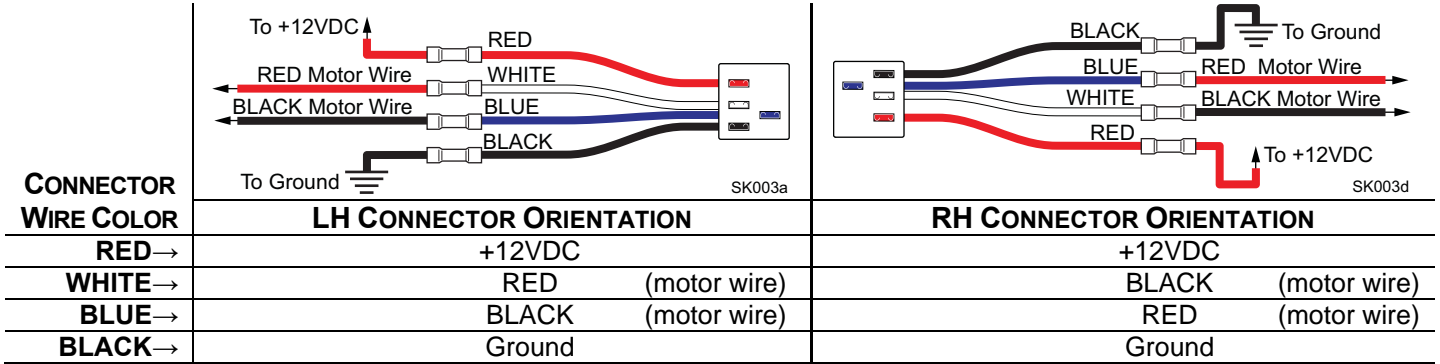

BT12 WIRELESS AWNING CONTROL SYSTEM

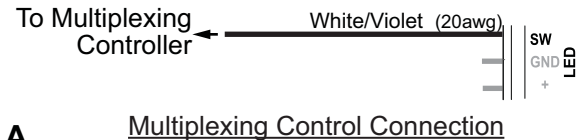
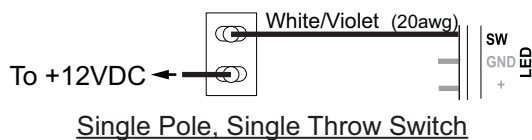
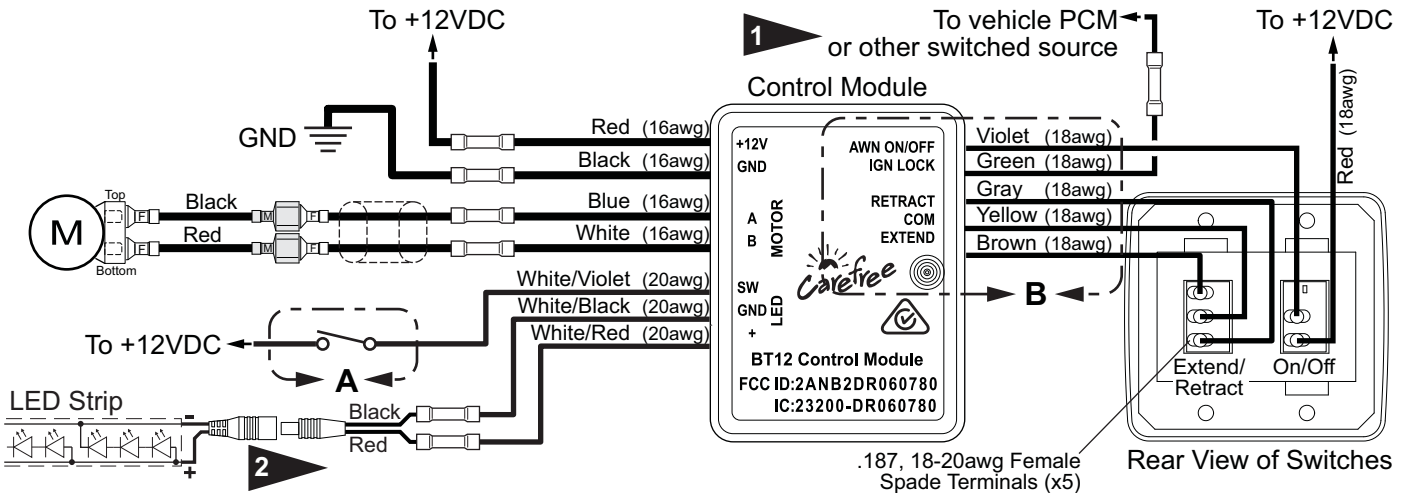

DETAIL A Awning Lights Switch Options

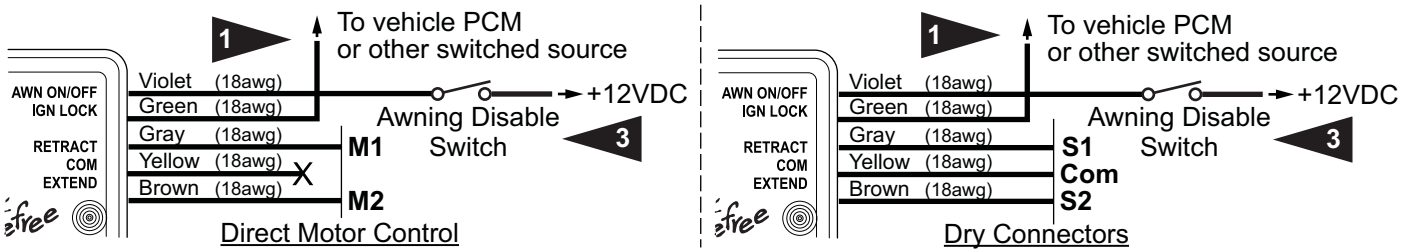

DETAIL B Multiplex Control System

BT002Lat

- 1 The BT12 module provides an ignition lockout option. When the "IGN LOCK" is connected to the vehicle PCM or other switched source the following parameters are set:
 - a) If Open = Awning Active
 - b) If tied to GND = RTL (Retract Then Lock) – Awning retracts, extend command disabled
 - c) If tied to +12Vdc = Standard – Extend command disabled
- 2 The LED connection is optional to provide LED controls through the app and remote for white LEDs only. White LEDs can also be installed per the standard LED installation without BT12 Controls.
- 3 The awning disable switch is a single throw; single pole switch used with OEM Multiplexing Control Systems. Switch is furnished by installer.

STANDARD MAINTENANCE

Maintaining the Carefree Manual Patio Awning is easy. Just follow these basic steps:

- Always operate the awning according to the instructions.
- Periodically check that the fasteners are tight. Tighten if necessary.
- Keep the awning fabric and arms clean.

FABRIC CARE

NOTICE Do not use oil based cleaners or any caustic, granulated, or abrasive type cleaners on your Carefree product.

1. One of the best ways to keep the fabric looking good and to delay the need for deep or vigorous cleanings is to hose fabrics off on a monthly basis with clear water. This practice will help prevent dirt from becoming deeply imbedded in the fabric. In most environments, a thorough cleaning will be needed every two to three years.
2. When it's time for a thorough cleaning, the fabric can be cleaned while still on an awning frame. Use a soft brush and warm water with soap.
3. When cleaning the fabric, it is important to observe the following:
 - Always use a natural soap, never detergent.
 - Water should be cold to lukewarm, never more than 100°F.
 - Air-dry only. Never apply heat to the fabric.
 - Always allow the fabric to dry thoroughly before rolling up the awning.

Mildew

Mildew is a fungus growth that looks like dirt. Vinyl coated polyester fabrics are mildew resistant because of a chemical biocide in the vinyl coating. Under ordinary conditions, mildew will not appear. However, in areas where high temperature and humidity are common, mildew can be a problem and required the material to be washed more frequently. Thoroughly rinse the fabric with clean water and allow to air dry completely before rolling up the awning.

Pooling

When water collects on the top of the fabric, this is known as "pooling". This can occur during inclement weather or if a running air conditioner discharges over the awning. The water is dumped when the awning is retracted. It is recommended that if water accumulates on the top; retract the awning in steps (8"-12") to dump the water. This will help prevent the fabric from stretching or distorting.

The effects of wind and rain on an awning are unpredictable. Severe damage to the awning and the vehicle may result. IF WIND OR EXTENDED PERIODS OF RAIN ARE EXPECTED, ROLL UP THE AWNING AND SECURE FOR TRAVEL.

ARM CARE

The best method of keeping the arms and braces operating smoothly is to clean them. Dirt and debris can cause the channels not to slide easily.

NOTE: Avoid introducing water into the motorized housings.

Periodically wash out the channels with running water (i.e. a hose) to keep them clean. If the arms still do not move easily, lightly spray the contact and pivot points with a dry silicone lubricant after the arms have been cleaned and dried thoroughly.

Hardware Maintenance

- Replace any parts that become damaged.
- Periodically check all mounting hardware, screws, lags, etc., and re-tighten when necessary.

EMERGENCY OVERRIDE

If power to the vehicle is not available, the awning can be safely retracted by jumping the motor using a 10V-14V power source such as a cordless drill battery or car battery.

NOTICE Do not use a 110V power source for the emergency override procedure! Doing so will permanently damage the awning! Do not use the emergency override without following the directions below.

1. Remove the front cover. The cover snaps onto the rear cover. To remove, press on both sides of the rear cover until the front cover releases then lift the front cover off.
2. Detach the RED and BLACK wires from the cable to the motor.
3. Attach jumper wires to the motor wires.
4. Connect the other ends of the jumper leads to a 10-14V source. If the awning moves in the wrong direction, reverse the leads. Maintain contact throughout the retraction process.
5. When the awning is closed, remove the jumper wires and reattach the cable wires to the motor wires. Be sure to match the wire colors.
6. Snap the front cover onto the rear cover. Hang the cover on the top and swing down until it clicks.

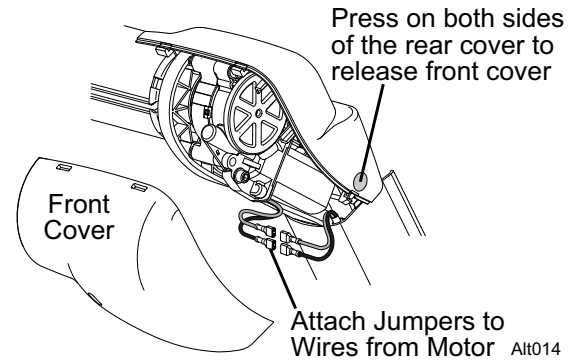

PART NUMBER LISTING

PART NUMBER/SERIAL NUMBER LOCATION

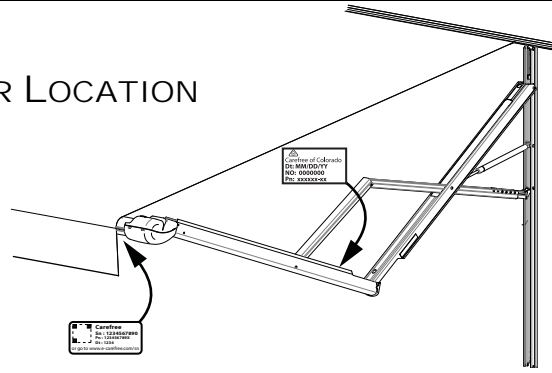

Carefree of Colorado
Part No. 0000000
Rev. 0000000

Arm information is located on the inside of the lower arm channel.

Carefree of Colorado
Part No. 0000000
Rev. 0000000

Roller tube part and serial numbers are located on the roller tube.

CO005

ILLUSTRATED PARTS LIST

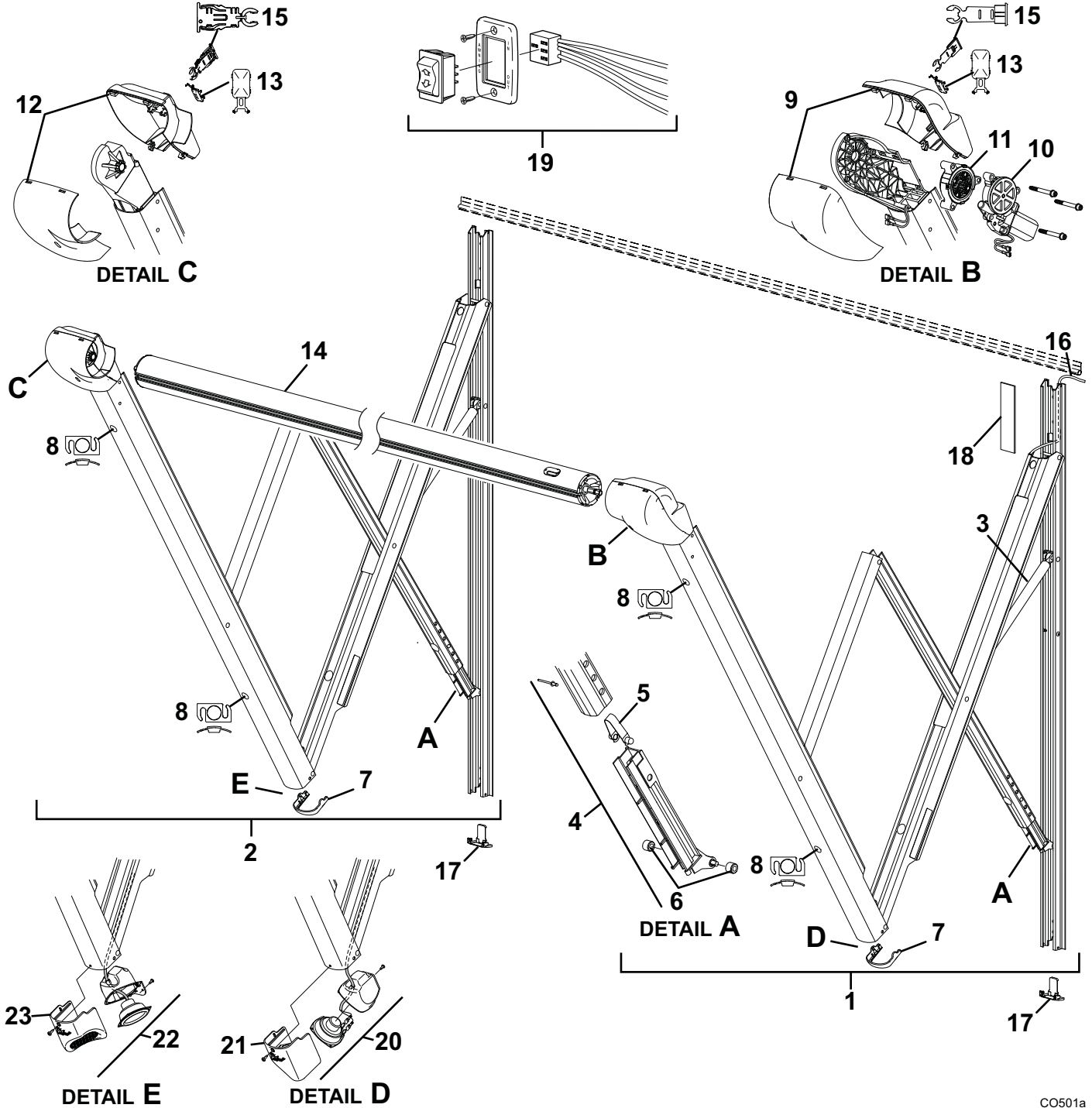

CO501a

<i>Item</i>	<i>Part Number</i>	<i>Description</i>	<i>Notes</i>
1a	R001988-XXX	Arm Assy, Motor Side, RH	
1b	R001986-XXX	Arm Assy, Motor Side, RH	with Speaker
2a	R001989-XXX	Arm Assy, Idler Side, LH	
2b	R001987-XXX	Arm Assy, Idler Side, LH	with Speaker
3	R001826	Kit, Gas Shock	
4	R001972-101	Kit, Pitch Adjust Assy, Mil	includes items 5, 6 and rivet
	R001972-102	Kit, Pitch Adjust Assy, Blk	includes items 5, 6 and rivet
5	R001945	Pitch Adjustment Pins	
6	R001840	Kit, Roller Replacement	
7	R001971-00X	Arm End Cap	
8	R001930-00X	Kit, Hole Plug	pkg of 4
9	R001931-00X	Cover Kit, Motor	2
10	R001832	Motor	
11	R001833	Gear Box	
12	R001932-00X	Cover Kit, Idler	2
13	R001835-00X	Kit, Clip Hole Cover Cap	
14a	R001841-xxx	Roller Tube Assy, No LED	
14b	R001842-xxx	Roller Tube Assy, w/ LED	
15	R001836	Kit, Retaining Clip	1 ea LH & RH
16		Power Harness, Motor	
17	017719-006	Wire Cover, Lower	pkg of 2
18	R041331-006	Wire Cover, Upper	
19	R019487-003	Switch Kit, Awning	3
20	R001984	Speaker Kit, RH (includes speaker, case and back cover)	4
21	R041596-001	Speaker Cover	used with item 20
22	R001985	Speaker Kit, LH (includes speaker, case and back cover)	4
23	R041596-002	Speaker Cover	used with item 22

- Notes: 1. 00X = Color; 005= White; 006=Black. xxx= Length in inches.
 2. Head cover kits include one front cover, one rear cover.
 3. Switch kit includes switch, faceplate, screws and connector.
 4. Speaker kit (item 20) is used with arm (item 1b). Speaker kit (item 22) is used with arm (item 2b).



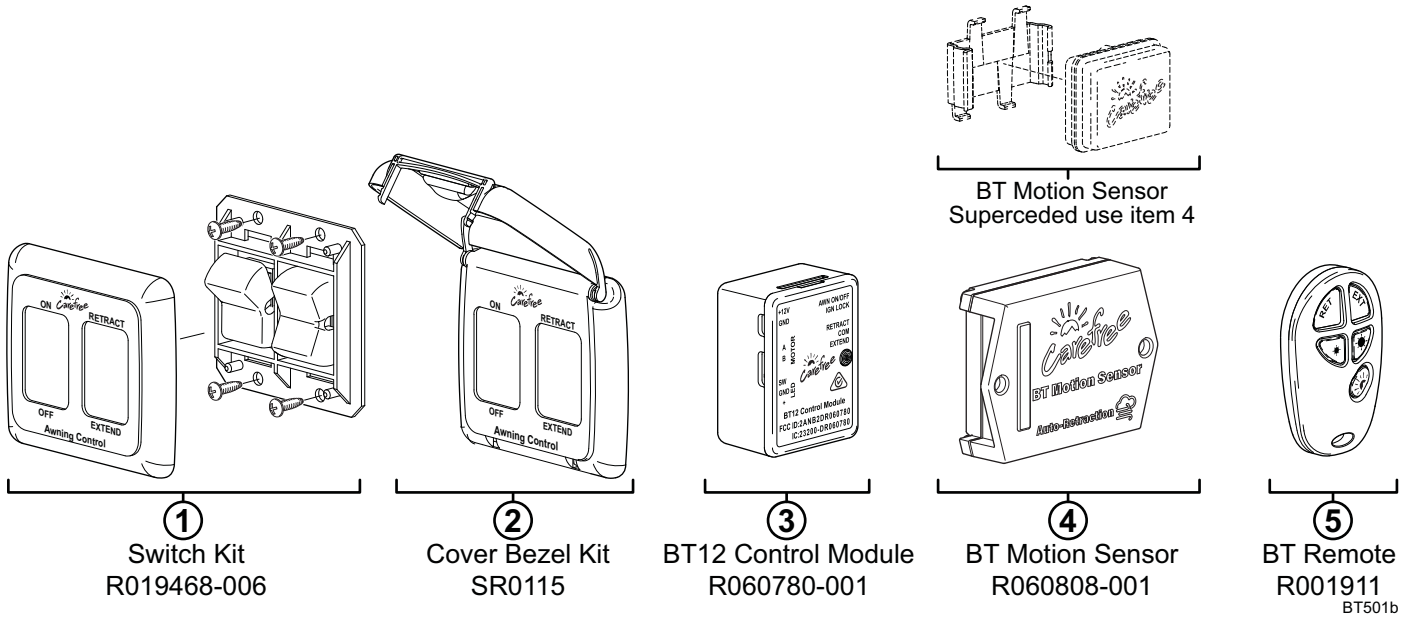

For LED replacement parts and service procedures refer to 052584-301 “LED Service Manual for Vertical Arms” available on-line at www.carefreeofcolorado.com

BT12 WIRELESS AWNING CONTROL SYSTEM COMPONENTS AND KITS

The following kits and components are available for the BT12 Wireless Awning Control System

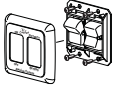

AVAILABLE UPGRADE KITS

Kit Number	Included Components				
	1 	2 	3 	4 	5 
R001911					Included
SR0115		Included			
901600	Included		Included		Included
901601	Included		Included	Included	
901602	Included		Included		
901603	Included		Included	Included	Included

NOTES: Kits are paired at the factory. Separate components that are added or used for replacements must be paired to the existing control module.

