



INSTALLATION MANUAL

ECLIPSE ARMS AND CANOPY

THIS PUBLICATION COVERS MODELS:

RV

- Universal Eclipse w/ Single Switch or Direct Response Electronics



Read this manual before installing or using this product. Failure to follow the instructions and safety precautions in this manual can result in personal injury and/or cause the product to not operate properly.



LED Lighting

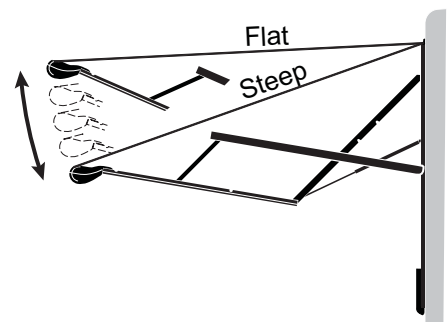

Adjustable Pitch

E0069

These instructions apply to OEM and Aftermarket Installations. Details and procedures unique to a specific application are labeled appropriately.

TABLE OF CONTENTS

Product Overview	1
Eclipse Patio Awning Specifications:.....	1
Eclipse Patio Awning Options:	1
Component Checklist.....	2
Installation	4
Required Pre-Installation Preparation.....	4
Installing an Awning Rail.....	4
Assembling the Awning	5
Mounting the Awning	6
Electrical	8
Wire Routing.....	8
Single Switch Installation	9
Direct Response Installation	10
Routing the Wire into the Vehicle	10
Installing the Switches	10
Wiring an Additional Patio Switch.....	11
Installing the Control Box	11
Installing the Remote Receiver.....	12
Programming the Receiver.....	12
Wiring Diagram - Direct Response	13
Ignition Lockout Sensor Installation (Optional)	14
Final Assembly	15
Attaching the Fascia and Bottom Cover	15
Securing the Fabric.....	15
Removing the Temporary Assembly Pins.....	16
Installing the Tractioners.....	16
Optional LED's	17
Wire Routing.....	17
Switch Installation	18
Power Connection for optional OEM RGB LED's	19

PROPRIETARY STATEMENT

The Eclipse Patio Awning is a product of Carefree of Colorado, located in Broomfield, Colorado, USA. The information contained in or disclosed in this document is considered proprietary to Carefree of Colorado. Every effort has been made to ensure that the information presented in the document is accurate and complete. However, Carefree of Colorado assumes no liability for errors or for any damages that result from the use of this document.

The information contained in this manual pertains to the current configuration of the models listed on the title page. Earlier model configurations may differ from the information given. Carefree of Colorado reserves the right to cancel, change, alter or add any parts and assemblies, described in this manual, without prior notice.

Carefree of Colorado agrees to allow the reproduction of this document for use with Carefree of Colorado products only. Any other reproduction or translation of this document in whole or part is strictly prohibited without prior written approval from Carefree of Colorado.

SAFETY INFORMATION



This is the safety alert symbol. It is used to alert individuals to potential personal injury hazards. Obey all safety messages that follow this symbol to avoid possible personal injury or death.



Indicates a hazardous situation, which if not avoided, could result in death or serious bodily injury.



Indicates a hazardous situation, which if not avoided, may result in minor or moderate bodily injury.



Indicates a situation that may result in equipment-related damage.

General Safety:



Shock Hazard. Always disconnect battery or power source before working on or around the electrical system.



Always wear appropriate safety equipment (i.e. goggles).



Always use appropriate lifting devices and/or helpers when lifting or holding heavy objects.



When using fasteners, do not over tighten. Soft materials such as fiberglass and aluminum can be "stripped out" and lose the ability to grip and hold.

CALIFORNIA PROPOSITION 65



This product contains chemicals known to the state of California to cause cancer or birth defects or other reproductive harm. California's Proposition 65 requires this warning to be given to customers in the state of California.

Reference Publications located @ www.carefreeofcolorado.com:

- 052568-001 Eclipse Arms and Canopy Installation Manual
- 052568-201 Eclipse Owner's Manual
- 052547-301 Eclipse Service Manual

PRODUCT OVERVIEW

- The unique "scissor" style arms eliminate the need for vertical ground supports.
- Easy to use 6 position pitch adjustment. The pitch can be left in any position and the Eclipse will roll up completely! When the awning is rolled back out, it rolls out to the pitch setting previously set.
- Worm gear style motor is billow proof - eliminates the need for travel locks.
- In the minimum (flat) pitch, the auto-dump feature automatically releases to allow water to run-off to prevent water pooling. When the water is gone, the arms return to the fully extended position.
- Can be installed using a single switch control or with the Direct Response™ electronic system. An RF remote is available with the Direct Response™ system.

Eclipse Patio Awning Specifications:

LENGTH	12' - 21' [366 - 640cm]		
EXTENSION:	7' 6 3/4" [230.5cm]	Drop @ Min. Pitch: 12" [30.5cm]	Drop @ Max. Pitch: 40" [102cm]
<i>Values are approximate, actual dimensions may vary with specific installations.</i>			
EXTENSION TIME:	28 Seconds (approx)		RETRACTION TIME: 32 Seconds (approx)
POWER REQUIREMENTS:	12VDC (operating range 10VDC to 14VDC) Circuit Rating: 15 amp		
POWER SOURCE:	Motor and controls are routed and hardwired into the vehicle's 12V system		
EMERGENCY RETRACT:	Electrical override system (external power source)		
COLOR:	<i>Hardware:</i>	White, Black or Satin	
	<i>Fabric:</i>	Heavy Duty Vinyl or Acrylic Fabric with Alumaguard or Uniguard <i>(refer to sales literature for colors)</i>	
	<i>Fabric Wrap:</i>	Weatherguard or Metal Wraps: Alumaguard or Uniguard	

Eclipse Patio Awning Options:

• Alumaguard Awning Wrap ²	• 12V Direct Response Auto-Retract System
• Uniguard Awning Wrap ²	• Remote Control ³
• SunBlocker	

NOTES:

1. Installation with optional SunBlocker shade requires a minimum power source of 12VDC (operating range 12VDC to 14VDC)
2. Selected at time of initial order.
3. Remote Control available with Direct Response installations only

COMPONENT CHECKLIST

Roller Tube

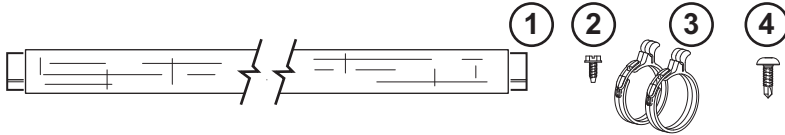

Single Switch (Standard)

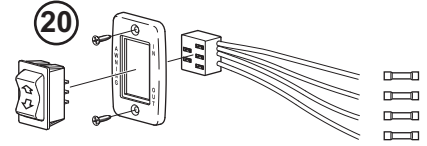

Arms

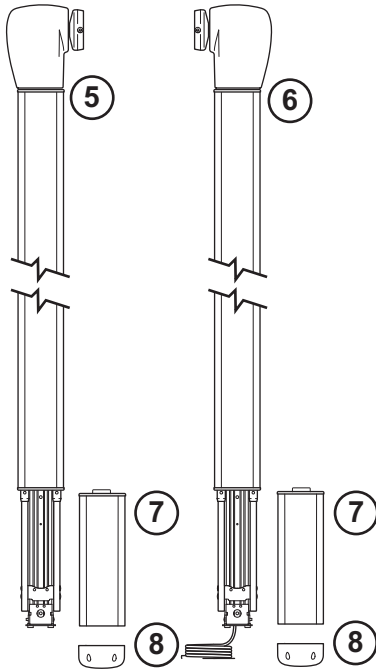

Common Hardware

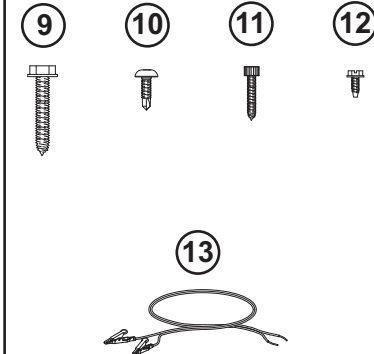

Direct Response (Optional)

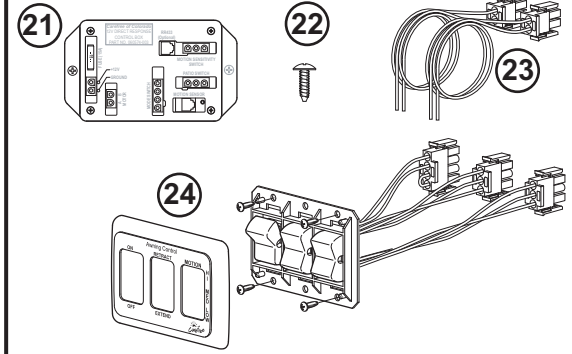

Rail Extension (aftermarket)

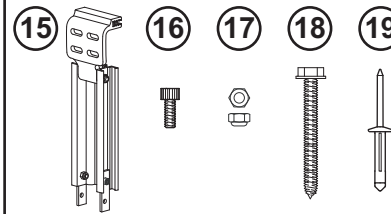

Remote Control Kit (Optional)

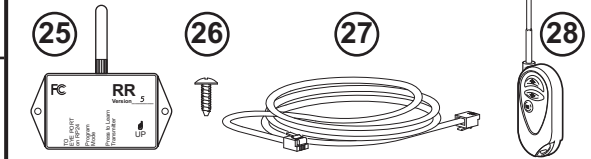

Ignition Lock-Out Kit (Optional)

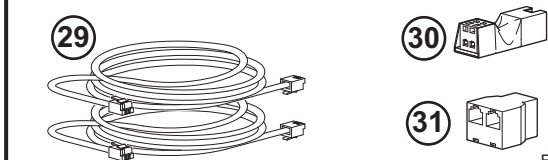

E0012c

Optional equipment and electronics are shown but may not be included with a particular arm set. Refer to the original purchase order to determine which options are applicable.

- The Rail Extension Kit is standard for aftermarket installations.
- For Aftermarket Direct Response, refer to Eclipse upgrade kit SR0036.
- Remote Control and Ignition Lock-Out are only available when Direct Response is installed.

<input checked="" type="checkbox"/>	ITEM	DESCRIPTION		QTY	NOTE
<input type="checkbox"/>	1	Rollbar Assembly		1	
<input type="checkbox"/>	2	Screw, HWHC	#6 x 3/8	2	
<input type="checkbox"/>	3	Tractioner		2	2
<input type="checkbox"/>	4	Screw, Truss Head, SQ Drive	#10 x 5/8	2	2
<input type="checkbox"/>	5	LH Arm Assy, Idler		1	
<input type="checkbox"/>	6	RH Arm Assy, Motorized		1	
<input type="checkbox"/>	7	Fascia Assy		2	
<input type="checkbox"/>	8	Bottom Cover		2	
<input type="checkbox"/>	9	Screw, Lag	1/4 x 1 1/2	8	
<input type="checkbox"/>	10	Screw, Truss Head, SQ Drive	#10 x 5/8	4	
<input type="checkbox"/>	11	Screw, SHC, Self-Tapping	#8 x 3/4	4	
<input type="checkbox"/>	12	Screw, HWHC	#6 x 3/8	2	
<input type="checkbox"/>	13	Jumper Cable		1	5
<input type="checkbox"/>	15	Rail Extension Kit		1	3,4
<input type="checkbox"/>	16	Screw, SHC	#10 x 1/2	4	3,4
<input type="checkbox"/>	17	Nylock Nut	10-32	4	3,4
<input type="checkbox"/>	18	Screw, Lag	1/4 x 2 1/2	8	3
<input type="checkbox"/>	19	Rivet, Moly	7/32	4	3
<input type="checkbox"/>	20	Switch Kit, Single Switch		1	6
<input type="checkbox"/>	21	Control Box, Direct Response		1	
<input type="checkbox"/>	22	Screw, Phillips Truss Head	#6 x 1/2	2	
<input type="checkbox"/>	23	Harness, Power, Motor		2	
<input type="checkbox"/>	24	Switch Kit, Direct Response	(includes bezel and connector harnesses)	1	
<input type="checkbox"/>	25	Receiver, RF, 433 MHz		1	
<input type="checkbox"/>	26	Screw, Phillips Truss Head	#6 x 1/2	2	
<input type="checkbox"/>	27	Cable	60"	1	
<input type="checkbox"/>	28	Remote Control Key FOB, 433MHz		1	
<input type="checkbox"/>	29	Cable	60"	2	
<input type="checkbox"/>	30	Sensor, Ignition Lock-Out		1	
<input type="checkbox"/>	31	Splitter		1	

- Notes:
1. Awning configuration is specified at time of order, including awning length, fabric, color and electronics. Check awning assembly against original purchase order.
 2. Screws and Tractioners are furnished with roller tube assemblies equipped with optional Alumaguard/Uniguard.
 3. Used with aftermarket installations.
 4. Rail Extension kit includes hardware for two arms (items 15, 16,17). Standard for aftermarket installations.
 5. Place Jumper Cable (item 14) with RV owner information. Installation manual, if included, is for installer reference.
 6. OEM's may choose to furnish the control switch (item 20). The switch must be a DC polarity reversing switch with dynamic brake.

INSTALLATION

REQUIRED PRE-INSTALLATION PREPARATION

1. Park the vehicle on a flat surface and level the unit.
2. If this is an upgrade for a manual patio awning, follow the awning manufacturer's instructions and remove the awning from the coach including the roll bar and canopy.
 - 2.1. Remove all brackets.
 - 2.2. Plug and seal all mounting holes. The new Eclipse arms may not match the locations of the old awning arms.
 - 2.3. Remove the roll bar from the arms and on a flat clean surface, roll the fabric onto the roll bar.
 - 2.4. If the canopy is equipped with Alumaguard, remove the tractioners and set aside. These will be reinstalled after the new awning assembly is installed.
3. Check where the awning arms will be installed. The arms fit snug to the side of the vehicle and must not cover or interfere with exhaust vents, lights etc.
4. If there is an awning rail installed, check that the awning rail runs the full length of the awning. Please refer to the note under "Installing an Awning Rail" before proceeding.
5. Refer to the important note on page 6 about the required positioning of the centerline of the roll bar.

INSTALLING AN AWNING RAIL

NOTE: For canopies WITHOUT Alumaguard or Uniguard: If the vehicle already has a full-length awning rail installed, skip to step 6.

For Alumaguard and Uniguard installations: If the existing awning rail is incorporated into the coach trim or a drip rail, it will be necessary to mount a standard awning rail flat on the coach wall. The awning rail and arms must be positioned so that any existing trim does not interfere with the Alumaguard or Uniguard's "Flex Connect" or the awning arm when in the closed position.

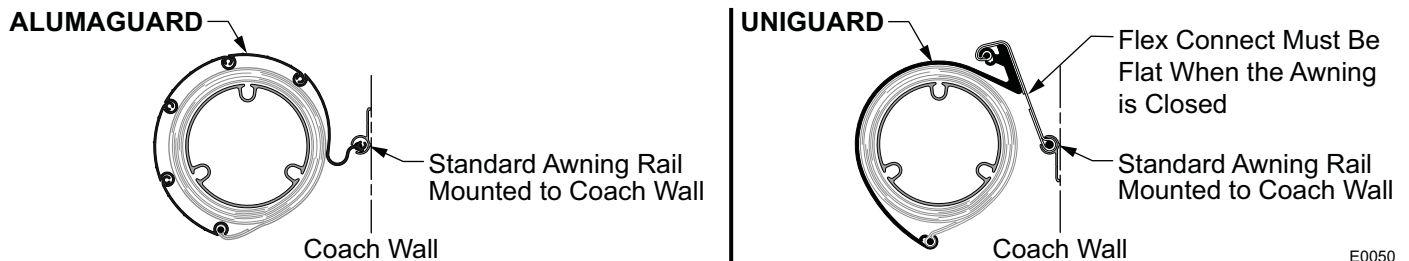

1. Determine the optimum positioning of the awning so that the arms will not interfere with the door frame or light fixtures. The centerline of the rail should be above the door opening a minimum of 6" for vinyl and 7" for Alumaguard/Uniguard. After determining mounting position, mark the position with a chalk line.
2. Awning rail must be level.
3. Seal the back of the rail with silicone sealant or putty tape.
4. Align the awning rail onto the wall and secure with #10 x 3/4" screws. Use all the attach holes in the rail.

NOTICE Make sure the screws are securely mounted to the structural frame of the vehicle.

5. Use a screwdriver to spread open one end of the awning rail on the installation side.
6. File any sharp edges or burrs from the end of the rail. This will help protect the awning fabric from damage during installation.
7. Spray inside the awning rail track with silicone lubricant.

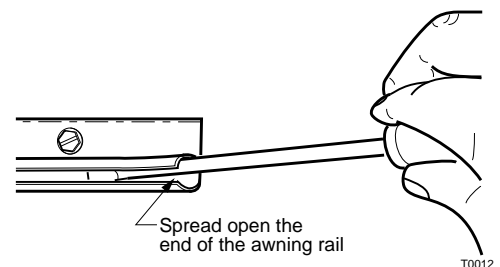

ASSEMBLING THE AWNING

1. Decide on the location of the switches and control box to determine the cable routing.
2. If the motor and Direct Response sensor cables are to be routed through the RV wall at the bottom of the arm, no modification is required. Go to step 3.
 - 2.1. If the motor and Direct Response sensor cables are to be routed through the RV wall at the top of the arm:
 - 2.2. Remove the plastic wrap at the top of the motorized arm. Partially open the arm being careful to not let the arm extend more than 6".

NOTE: The arm is under tension from the gas shock located in the arm.
 - 2.3. Pull the cable(s) out of the slot(s) in the rear of the back channel and pull the cables out of the hole in the top of the channel.
 - 2.4. Secure the top of the arm in the closed position using a plastic wrap or equivalent.
3. For Aftermarket Installations: An extension kit is furnished for aftermarket installations.
 - 3.1. At the top of the arms, remove the rail caps.
 - 3.2. Attach the rail extension to the rail as shown.

NOTICE During assembly and installation, The arm assemblies must remain perpendicular to the roller assembly. Failure to handle the arms carefully can bend the drive shaft.

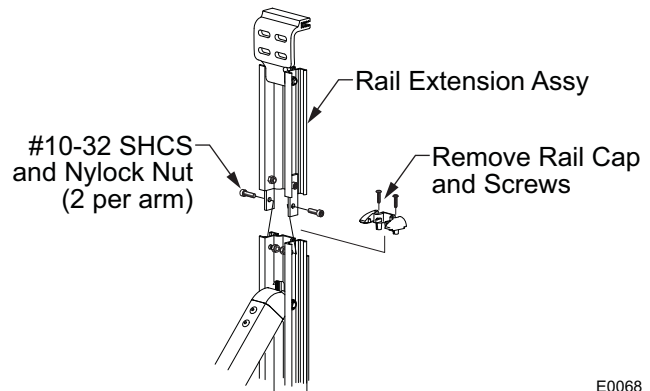

E0068

4. Align the roller assembly with the end cap on the motorized arm assembly. Rotate the end cap until the slot in the cap aligns with the empty slot in the roller assembly, and then press the roller assembly fully into the cap. The end cap must seat squarely over the end of the roller assembly when complete.

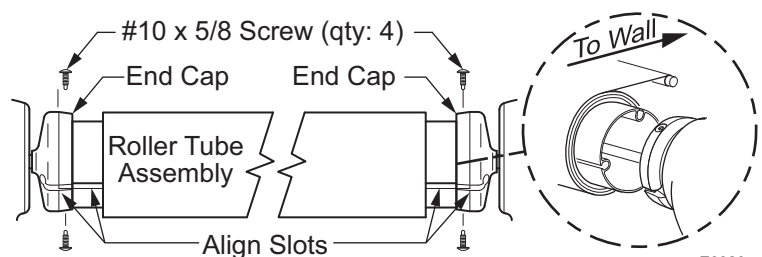

E0020a

- NOTE:** The roller assembly must be oriented with the fabric going over the roller toward the mounting surface.
5. Secure the end cap to the roller tube assembly using two #10 square-drive screws.
 6. Repeat steps 4 and 5 to attach the non-motorized arm assembly to the roller tube assembly.

MOUNTING THE AWNING



CAUTION

size and weight.

It is recommended that at least three people install the awning due to its

NOTE: For the bottom 3 mounting holes: if mounting into structure, use the 1/4 x 1 1/2 screws; if not attaching into structure, use the moly rivets.

The upper mounting holes must attach into structure using the screws provided. If structural backing is not available for the upper mounting holes, it will be necessary to use the aftermarket rail extension so that the upper brackets can mount into the structural members at the roof line.

1. Check the location where the awning is to be mounted. Ensure that the awning will not interfere with other equipment on the vehicle, such as a slide out room, light fixtures, exhaust vents etc.
2. On the awning rail, mark the location of the centerline of the arm assemblies.
3. From those marks, measure down vertically a distance of $55" \pm 1/4"$ from the centerline of the awning rail. These will be the initial mounting holes.

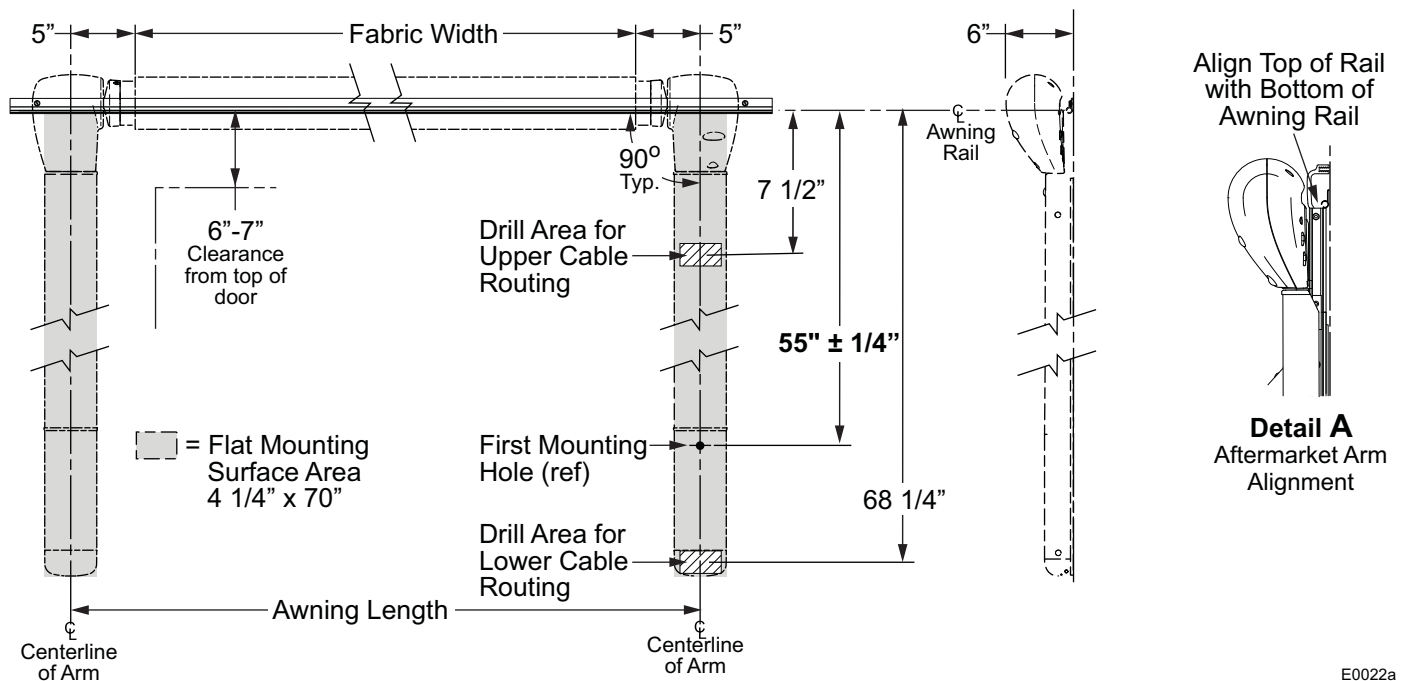

E0022a

4. Unroll the canopy one wrap.
5. With one person holding each arm, the third person should thread the polyrod (the plastic rod on the edge of the fabric) into the awning rail, starting at one end. Carefully move across the vehicle, gently pulling the fabric into the rail, until the awning is in the pre-determined location.

NOTE: While the awning fabric is fairly robust, care must be taken not to snag it on the awning rail.

6. For installations without the rail extension: Align the first mounting hole in the motorized arm with the location marked in step 2. The arm assembly must be perpendicular to the awning rail.
7. For installations with the rail extension: Butt the top of the rear channel against the awning rail as shown in Detail A.

IMPORTANT NOTE: For Uniguard and Alumaguard installations, the centerline of the roll bar must be $3/4" \pm 1/4"$ above the centerline of the awning rail.

8. Drill a $5/32"$ hole at the first mounting hole for the RH (motorized) arm
 - 8.1. If the hole goes into a structural member, attach the motorized arm using a 1/4 x 1 1/2" lag screw.
 - 8.2. If the hole is through the outer skin only, ream the hole out to 1/4" and attach arm with a moly rivet.

9. Confirm that the arm is perpendicular to the awning rail, repeat step 9 and attach the arm at the second mounting point (shown in Figure 6).
10. Position the roller assembly so that it is perpendicular to the motorized arm assembly. Position the non-motorized arm perpendicular to the roller assembly.
11. Drill a 5/32" hole at the first mounting hole for the RH (motorized) arm
- 11.1. If the hole goes into a structural member, attach the motorized arm using a 1/4 x 1 1/2" lag screw.
- 11.2. If the hole is through the outer skin only, ream the hole out to 1/4" and attach arm with a moly rivet.
12. Check the alignment; the arm assembly must be perpendicular to the roller assembly. When the alignment is correct, drill and attach the idler arm at the second mounting hole.
13. Hold the awning closed and carefully remove the plastic wraps at the top of the arms. The awning will open a few inches.
14. Cap or cover the exposed ends of the motor wires. **This is to prevent accidental shorting or grounding during assembly.**
15. Open the awning about 18" or until the top mounting holes on the arms are visible. To open
- 15.1. Use the supplied jumper cables and attach to the emergency terminals located on the top of the motorized head.
- 15.2. Connect the other ends of the jumper leads to a 12V source. If the awning does not begin to move, reverse the leads.
16. Using a 5/32" drill bit, locate and drill the mounting holes.
17. Attach the top of the arm assemblies to the vehicle.
- 17.1. For installations without the rail extension: Use a 1/4 x 1 1/2 lag screw through the top mounting hole for each arm.
- 17.2. For installations with the rail extension: Use two (2) 1/4 x 2 1/2 lag screws for each arm.

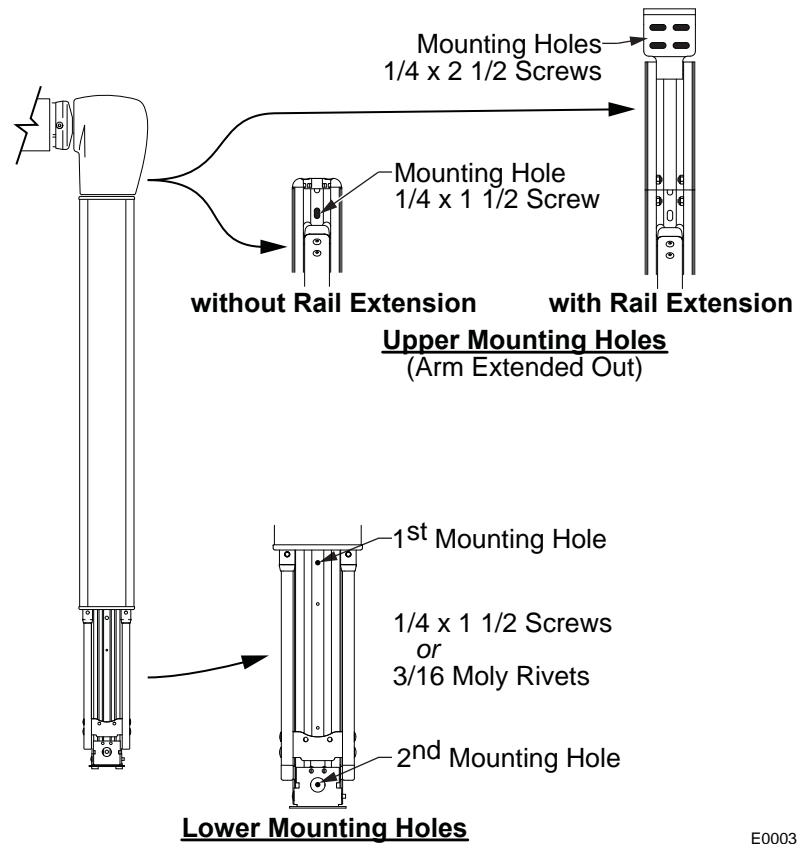

E0003

ELECTRICAL



WARNING Shock Hazard. Always disconnect battery or power source before working on or around the electrical system.

- Notes:**
1. Failure to follow the wiring instructions in this publication may void the motor warranty.
 2. DO NOT wire two or more motors to one switch—No parallel wiring.
 3. All wiring must conform to NEC (National Electrical Code) and local codes.
 4. OEM's may choose to furnish the control switch. The switch must be a DC polarity reversing switch with dynamic brake.

The standard Eclipse Patio Awning comes with a single switch. The single switch configuration has one interior extend/retract switch. The Eclipse is also available with the optional Direct Response auto retract system.

WIRE ROUTING

1. Determine the final location of the switch and mark the location.
2. Drill a 5/16" hole through the vehicle wall for the motor cable.
3. Route the cable through the holes to the location of the switch panel.
4. Seal the cable and hole using a quality sealant.

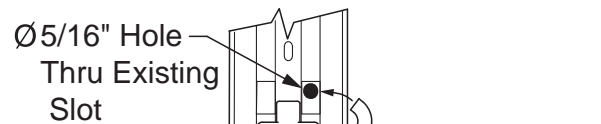

Top of Channel Routing

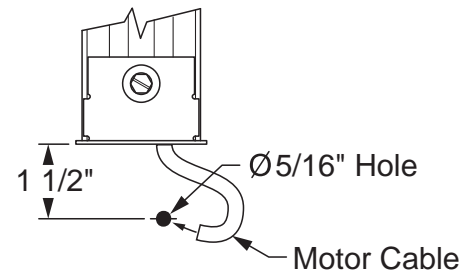

Bottom of Channel Routing

E0005



If installing the BT12 Wireless Awning Control System use the wiring and setup instructions in "070029-001 BT12 Installation Manual".

Manual is available on-line at www.carefreeofcolorado.com/carefreeconnects.

SINGLE SWITCH INSTALLATION

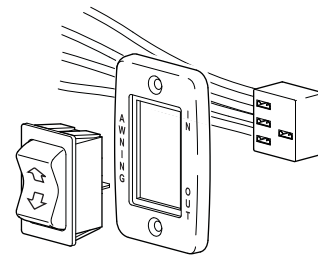
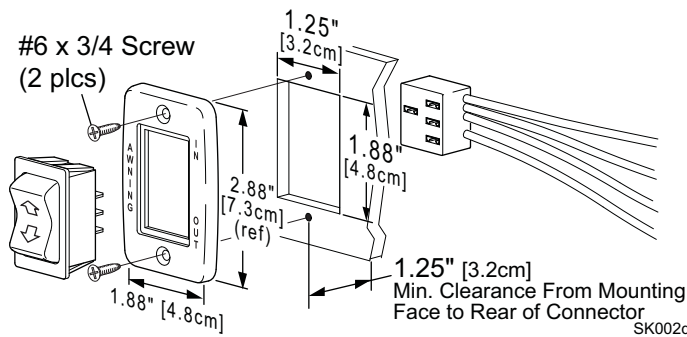

Left Side Orientation

SK002a

1. At the switch location, cut a rectangular hole 1.25" (3.2cm) x 1.88" (4.8cm) through the mounting surface.
2. Determine the switch orientation:
 - 2.1. The wires of the connector extend from the side of the switch with 3 terminals on the back.
 - 2.2. For wire routing on the right side of the switch as shown in Details A and B, orient the switch with the 3 terminals on the right.
 - 2.3. For wire routing on the left side of the switch as shown in Detail C, orient the switch with the 3 terminals on the left.
 - 2.4. Push the switch into the faceplate until the tabs on the switch "click" into place behind the faceplate. Ensure that the switch and faceplate are oriented so that the lettering is up and the wires are oriented as desired.
 - 2.5. Set switch aside.
3. Route the awning motor wires through the switch hole and attach to the switch connector:

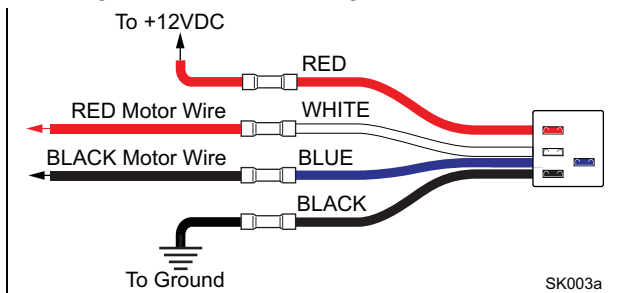

SK003a

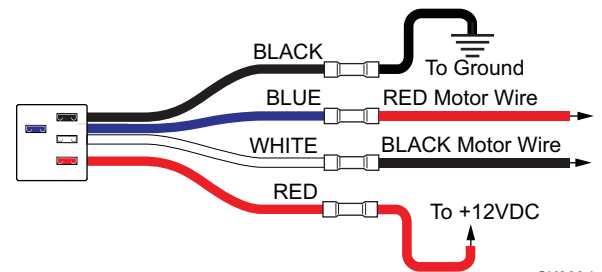

SK003d

CONNECTOR WIRE COLOR	LH CONNECTOR ORIENTATION	RH CONNECTOR ORIENTATION
RED →	+12VDC	+12VDC
WHITE →	RED (motor wire)	BLACK (motor wire)
BLUE →	BLACK (motor wire)	RED (motor wire)
BLACK →	Ground	Ground

5. Run a minimum 14 awg wire from the power distribution panel (auxiliary battery circuit) or equivalent. The circuit should be protected by a 15-amp fuse.
6. Run a minimum 14 awg wire to system ground.

NOTE: If the wire run is 30 feet or longer, use 12awg wire to prevent voltage drop.
4. Route the two wires through the mounting hole. Butt splice the 12VDC wire to the RED connector wire. Butt splice the ground wire to the BLACK connector wire.
5. Attach the connector to the switch.
6. Restore power and test the switch operation.
7. If the awning operates opposite to the switch plate markings:
 - Shut off power;
 - Reverse motor wires connected to the blue and white connector wires;
 - Restore power and test.
8. Push the wires, connector and switch into the mounting hole and secure the switch plate. Use two (2) #6 x 3/4" flat head screws.

DIRECT RESPONSE INSTALLATION

Direct Response is available as a factory installed option for OEM's. For aftermarket installations, the Direct Response system is available as an upgrade kit SR0036.

Routing the Wire into the Vehicle

1. Determine the final layout of the switches and the control box and mark the locations.
2. For installations using the cables with direct connections (no external plug):
 - 2.1 (Refer to **Error! Reference source not found.**) Drill two 5/16" holes through the vehicle wall for the motor cable and exterior switch cable. Move the cables out of the way to avoid damage while drilling.
 - 2.2 Drill a 1/4" hole for the sensor cable.
 - 2.3 Cut off the existing connector on the sensor cable then route the wires and cable through the holes to the location of the control box.
 - 2.4 Seal the cables and holes using a silicone sealant.

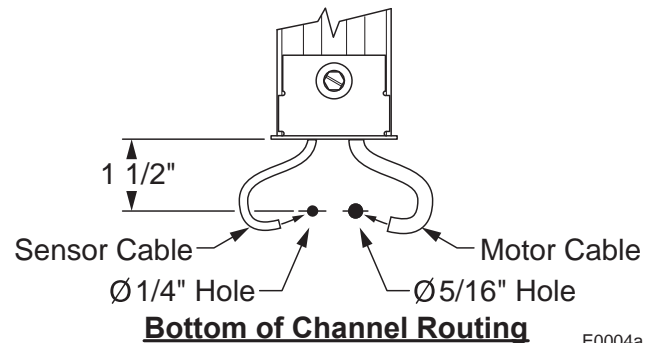
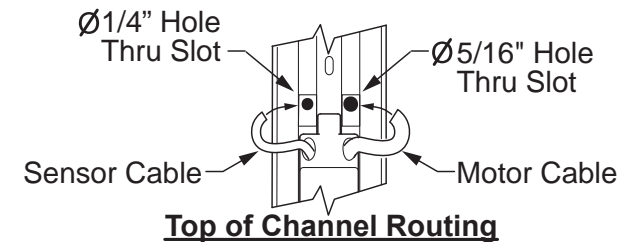

E0004a

Installing the Switches

1. At the switch location cut a 3.5" [8.9cm] x 1.5" [3.8cm] hole
2. Push the wires and switches into the hole then attach the switch frame using four (4) #6 x 1/2" screws.

⚠ CAUTION Ensure that the switches are oriented with the ON/OFF switch on the left to match the faceplate labels for the switch identification and orientation.

Tip: Drilling a small pilot hole for the screws will reduce the chance of splitting or stripping out the holes in the mounting.

3. Press the face plate onto the switch frame.

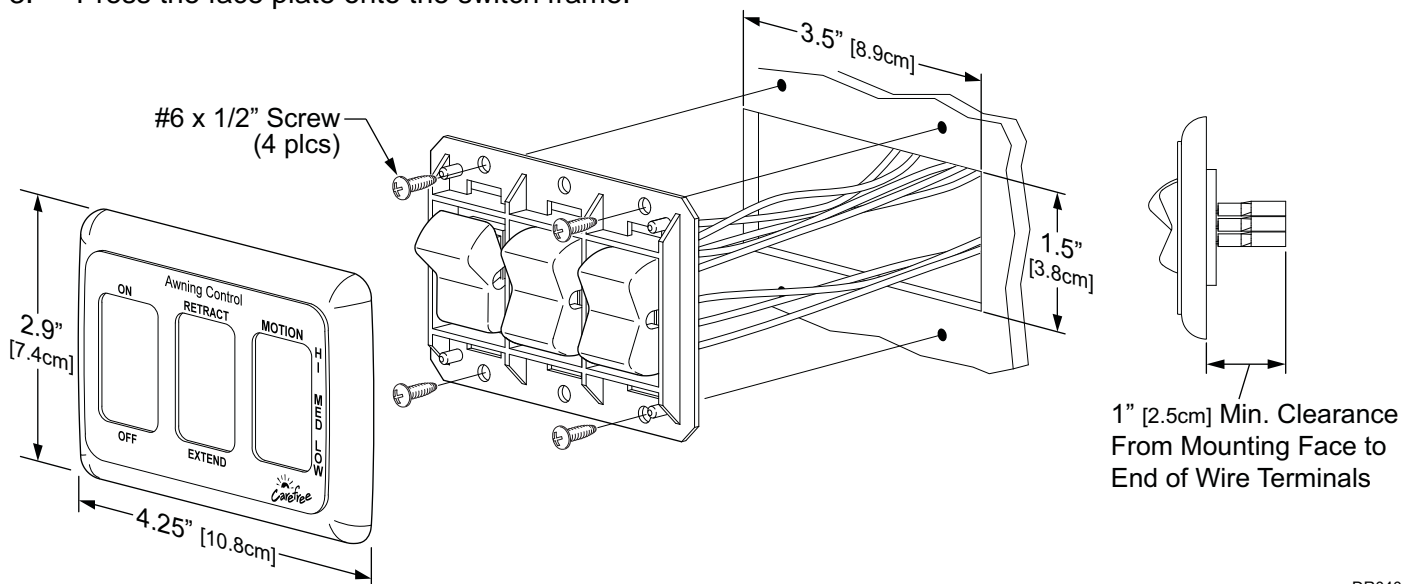

DR040

Wiring an Additional Patio Switch

This section is for wiring an additional PATIO switch.

(refer to the wiring diagram on page 13)

1. Route the switch wires to the main switch location.
2. Splice the wires in parallel with the EXTEND/RETRACT switch wires. Pin 1 of the additional switch should go to pin 1 of the main patio switch etc.

Installing the Control Box

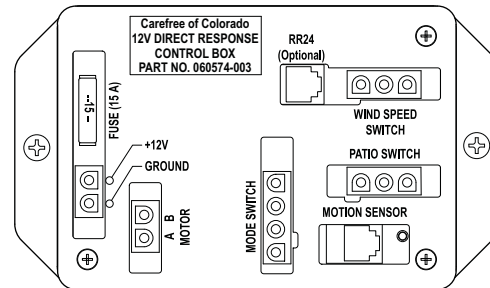
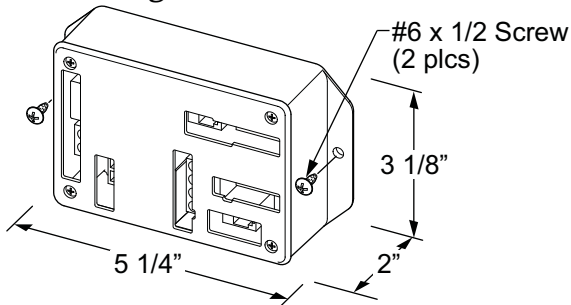

DR008

1. Position the control box and secure using two (2) #6 x 1/2" screws.
2. Attach the switch harness connectors to the box at the positions labeled on the box. Press the connectors in until the tabs click into place to ensure a solid connection.
3. Use a 4-conductor modular plug crimp tool to install a new RJ-11 4-conductor plug to replace the connector removed previously. **THE CABLE AND PLUG MUST BE ORIENTED AS SHOWN FOR PROPER SYSTEM OPERATION.**
4. Connect the cable from the Direct Response sensor to the control box.
5. Connect a two-wire harness to the control box in the position marked MOTOR.
6. Run the motor wire cable from the awning to the control box. Splice the wires to the connector harness in step 5. The red wire should go to the pin marked "B" and the black goes to the pin marked "A".
NOTE: During testing, it may be necessary to reverse these wires (red to B, black to A) if the awning extend and retract functions are reversed.
7. Connect power to the control box;
 - 7.1. Run a 12 gauge wire (never use less than 14 gauge) from the power distribution panel (auxiliary battery circuit) or equivalent.
 - 7.2. Run a wire to chassis ground. Suitable ground would be the vehicle chassis or conductive structure connected to the chassis.
 - 7.3. Connect a two-wire harness to the control box in the position marked +12V/GROUND.
 - 7.4. Splice the wires from steps 2 and 3 to the harness. Carefully note the labeling on the box so that the 12V power goes to the 12V pin and the ground goes to the pin labeled ground.

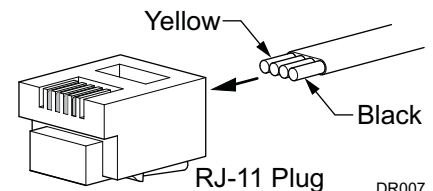

DR007

Installing the Remote Receiver

1. Determine the location of the optional RF receiver:
 - 1.1 Do not mount the unit near heat producing elements such as LP appliances or engine exhaust components.
 - 1.2 For best reception, do not mount the unit near or on a metal surface.
 - 1.3 Mount the unit with the antenna pointing up.
 - 1.4 The included cable is approximately 60 inches long. Mount the unit close enough to the control box so that the cord can be connected without stressing the connections.
 - 1.5 Allow room below the box to access the connector jack, programming button and indicator light.
2. Position the control box and secure using two (2) #6 x 1/2" screws.

NOTE: If the box is mounted on a surface that is less than 1/2" thick, the screws will protrude through the opposite side of the surface.
3. Connect the cable to the receiver.
4. If using the Ignition Lockout Sensor, route the cable to the splitter and connect. If not using the sensor connect the cable directly to the control box

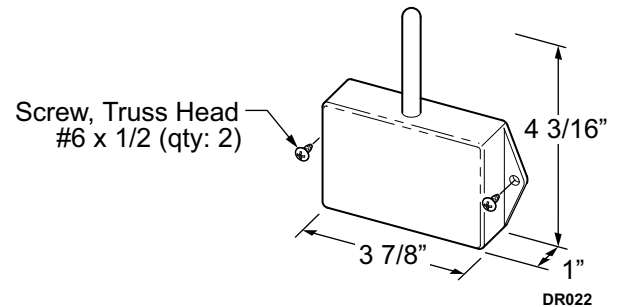

Programming the Receiver

These instructions apply to the current 433 MHz configuration of the remote and receiver. For older versions (418 MHz) refer to the Eclipse Service Manual.

1. Power to the control box must be on.
2. Press and release the "Press to Learn Transmitter" button on the bottom of the receiver box. The receiver is in program mode when the red light comes on.
3. Press and release the stop button on the remote. The red light will go out after the receiver learns the remote signal.

NOTE: Pressing the stop button will cause the blue up arrow button to default as the close (retract) function.

If a function button is pressed to train the receiver, it will be programmed as the close (retract) button. Example: Pressing the bottom button will program the bottom button for retract and the top button as extend.

4. Repeat for each additional remote.

OPERATIONAL NOTES:

- Transmitter and receiver operate on a frequency of 433 MHz.
- The receiver exits the program mode after ten seconds.
- If the light does not come on above, the memory is full and must be cleared. If the light still does not come on, check the continuity of the cord between the boxes and repair or replace as required. Pin 1 of the 1st connector goes to pin 1 of the 2nd connector etc.
- If the light does not go out in above, the receiver already knows the transmitter's signal or the battery in the remote needs to be replaced.
- To clear the memory: PRESS AND HOLD the transmitter learn button. While holding the button, the indicator light should be OFF for the full 5 seconds then come on.
- The system may be programmed for up to 5 remotes. Additional remotes may be ordered separately.

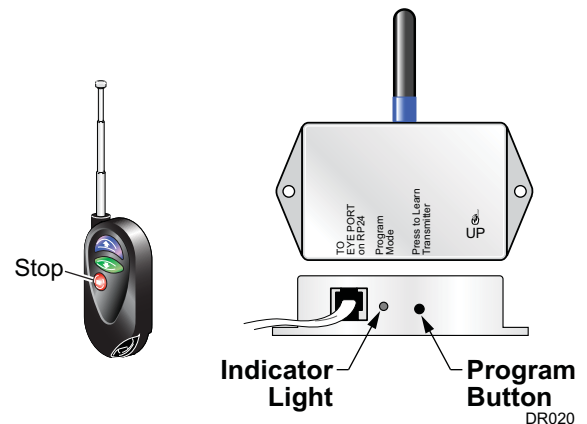

Wiring Diagram - Direct Response

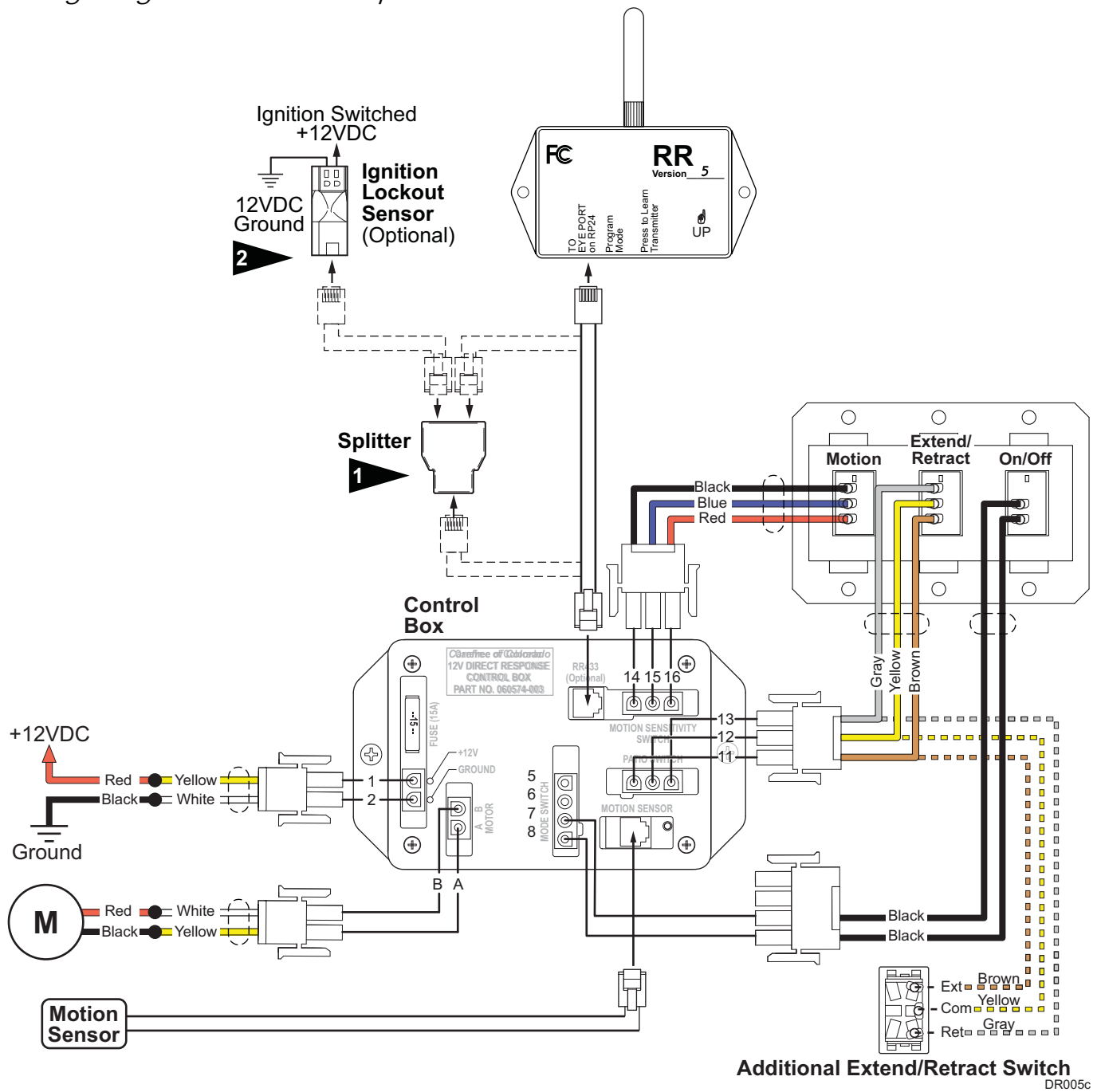

- 1 Splitter is used only when the optional Lock-Out Sensor is installed. Connect the RF receiver directly to the control box if Lock-Out is not installed.
- 2 The optional Lock-Out Sensor can be used only with control boxes marked "060574-003". Wires for the sensor are not pin specific.

Ignition Lockout Sensor Installation (Optional)

The optional STD ignition lockout will disable the extend function when the module receives a current through a switched 12VDC circuit.

A switched 12VDC source is a line that is "hot" when the ignition switch is in the on position; or, a 12VDC circuit through a relay that is "hot" when a specific condition is met (i.e. releasing the parking brake). Relays are furnished by the installer.

(Refer to the wiring diagram on page 13)

1. Disconnect power to the awning. Disconnect the battery or pull the appropriate circuit breaker.
2. Locate the control box for the Direct Response System.

NOTE: The 6" cable and splitter are for systems with a remote. If there is no remote, attach the 60" cable to the module; plug the other end of cable directly to the "RR24" port in the control box. Then proceed with step 8.

3. If there is a remote receiver, disconnect the cable from the "RR24" port in the control box. Do not disconnect the cable from the receiver box.
4. Connect the supplied 6" cable to "RR24" port in the control box.
5. Attach the splitter to the other end of the cable.
6. Plug the cable from the remote receiver into the splitter.
7. Attach the Lock-Out Sensor to the end of the 60" cable. Route the cable as desired and connect the cable to the splitter.

NOTE: Wires to the module are not pin specific.

8. Attach one 18-gauge wire to a terminal of the sensor and route the wire to a suitable 12VDC ground.
9. Attach a second 18-gauge wire to the second terminal of the sensor and route the wire to a SWITCHED 12VDC source.

A switched 12VDC source is a line that is "hot" when the ignition switch is in the on position; or, a 12VDC circuit through a relay that is "hot" when a specific condition is met (i.e. releasing the parking brake). Relays are not furnished with this kit.

10. Bundle and secure the sensor, cable and wires as required.

FINAL ASSEMBLY

ATTACHING THE FASCIA AND BOTTOM COVER

1. Make sure the awning is completely closed.
2. Insert the tab, on the fascia, under the arm base and rest it on the mounting plate.
3. Check that the gap between the top of the fascia and the arm channel is approximately 1/8".
 - If the gap is too large or too small, set the fascia aside, loosen the mounting plate screws and adjust the mounting plate height as required. Tighten the screws and set the fascia in position.
4. Place the bottom cover beneath fascia. Carefully tuck any wires into the bottom cover.

NOTE: There are tabs on the top of the cover to correctly align the bottom cover and fascia. The fascia should seat in the groove of the cover.
5. Attach the cover to the fascia with the supplied socket head screws using a 9/64" Allen wrench. The screws must go through the cover, the plate, and the fascia.
6. Repeat for the other side.
7. Verify proper installation by opening and closing the awning.

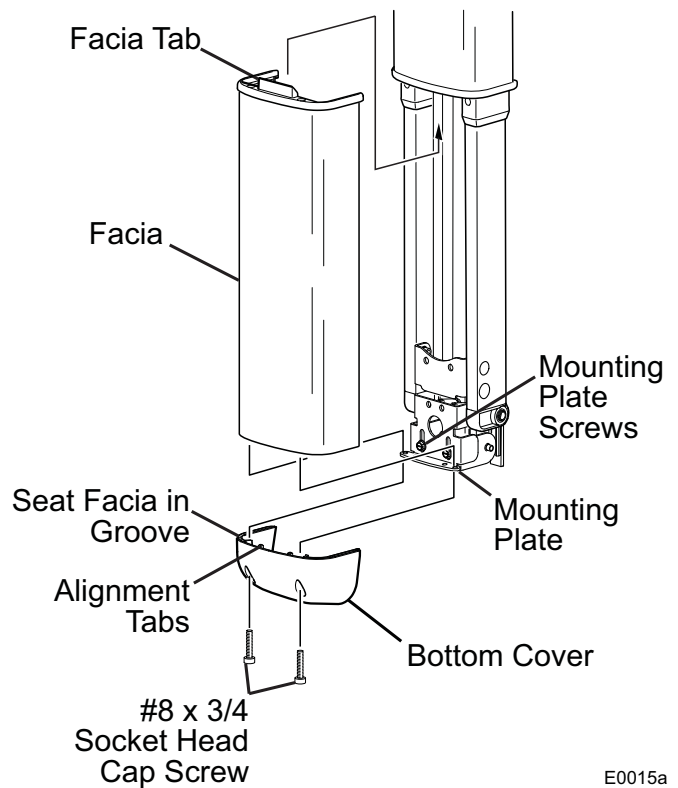

E0015a

Figure 1. Attaching the Fascia and Bottom Cover.

SECURING THE FABRIC

1. Roll the awning in and out several times to make sure that the fabric is square on the rollbar.
2. Secure the canopy using one, #6 x 3/8" hex head screw at both sides of the awning.

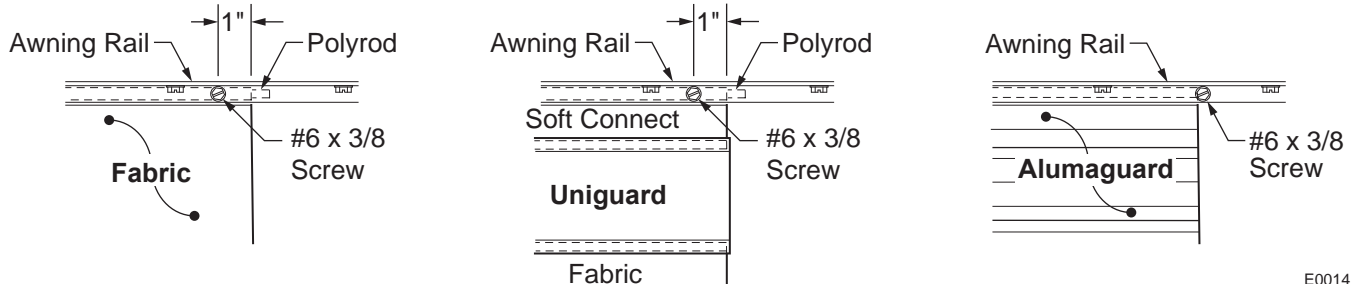

E0014

Figure 2. Securing the Fabric.

- 2.1 For vinyl awnings, place screw through awning rail, polyrod and canopy approximately 1" in from the end of the fabric.
- 2.2 For Uniguard awnings, place screw through awning rail, polyrod and the soft connect material approximately 1" in from the end of the fabric.
- 2.3 For Alumaguard awnings, place screw on the outer edge of the Alumaguard (not through the Alumaguard).

REMOVING THE TEMPORARY ASSEMBLY PINS

2 pins are inserted into the back of the left (idler) head for lateral stability during installation. Using a pair of pliers, remove and discard both pins.

NOTE: The awning will operate with the pins in place; for long term use, the pins must be removed to allow for climate variances.

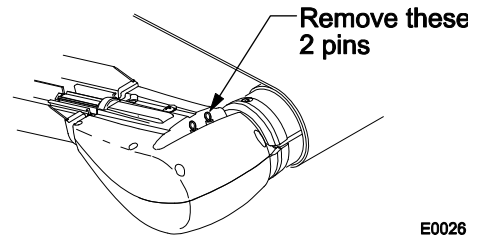

E0026

INSTALLING THE TRACTIONERS

The tractioners are used with the Alumaguard and Uniguard metal fabric wraps.

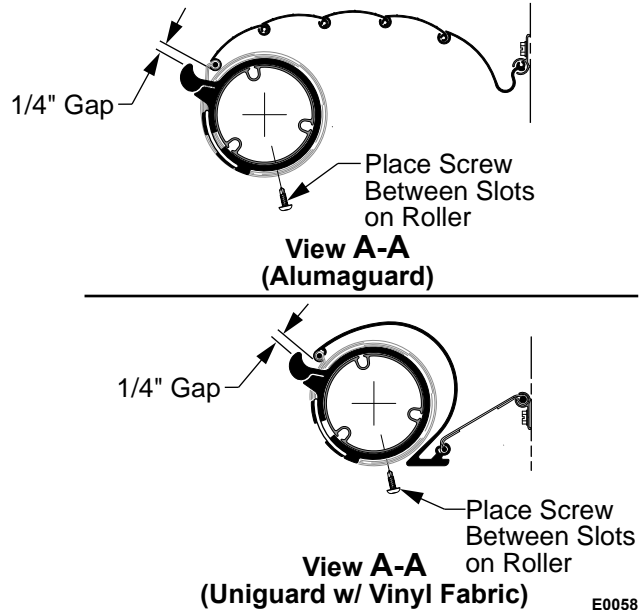
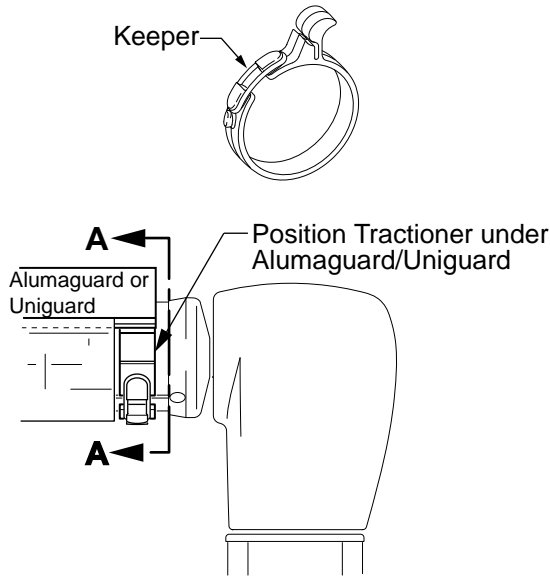

E0058

1. Partially extend the awning until the Alumaguard/Uniguard is extended as shown.
2. Unlock the keeper and wrap the tractioner around the roller tube.
3. Position the tractioner under the Alumaguard/Uniguard with a 1/4" gap between Alumaguard/Uniguard and tractioner. Lock the keeper.
4. Repeat for the other end of the rollbar.
5. Extend the awning to verify that the tractioners are lifting the metal wrap up and over the roller assembly.
6. To secure the tractioner, drill a 1/8" hole through the tractioner and rollbar, roughly center the hole between two slots of the rollbar.
7. Secure with one (1) #10 square drive screw.

OPTIONAL LED'S

Optional White LED light strips mounted in the roller tube are available for aftermarket and OEM installations. Some OEM's may offer LEDs at the awning rail.

NOTICES:

- a. Do not route the wire over sharp edges or heat sources that can cut or fray the wires or wire insulation.
- b. Damage that is a result of improper routing may void warranty.

WIRE ROUTING

1. For roller tube LED's:

- 1.1 Route the LED canopy harness wires into the vehicle with the awning motor wires as shown.
- 1.2 Allow a minimum 3" loop between the canopy and rear channel
- 1.3 Secure the LED harness inside the channel with a quality silicone sealant.

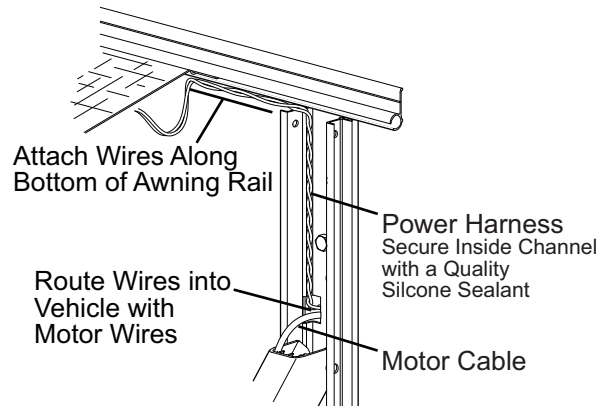

Canopy Harness

2. For optional OEM awning rail LED's:

- 2.1 Route the LED power harness into the vehicle with the awning motor wires. Allow 3" - 4" to extend past the top of the channel.
- 2.2 For white LED's: On the outside of the vehicle connect the power cord to the LED strip.

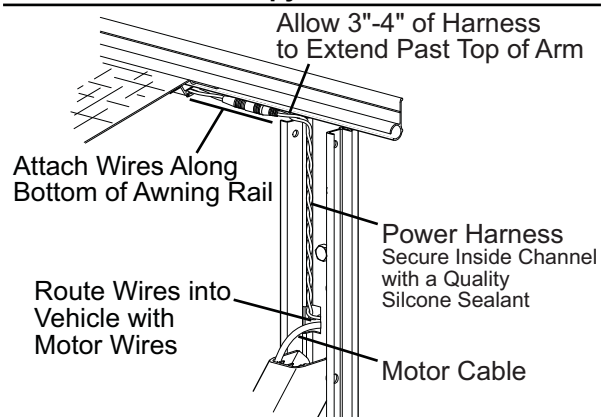

Awning Rail LED

LED001a

SWITCH INSTALLATION

A single pole switch is required for the white LED installations.

For optional OEM RGB installations the single pole switch can be used as an optional power on/off control. This allows the lights to be shut off if the awning is retracted with the lights on.

NOTES:

- Installers may choose to furnish the control switch. The installation requires that the power line (+12VDC) be attached to a dedicated 2A circuit breaker or a 2A in-line fuse must be installed between the switch and power source. For easy access, locate the fuse close to the switch.
- Per RVIA Low Voltage Systems in Conversion and Recreation Vehicles Chapter 3, Section 3-1: For Carefree LED strip lighting near the awning rail: when the 24AWG power harness is spliced or connected 10" or less from the harness connector using a heavier gauge wire, the fuse size is determined by the heavier wire gauge.

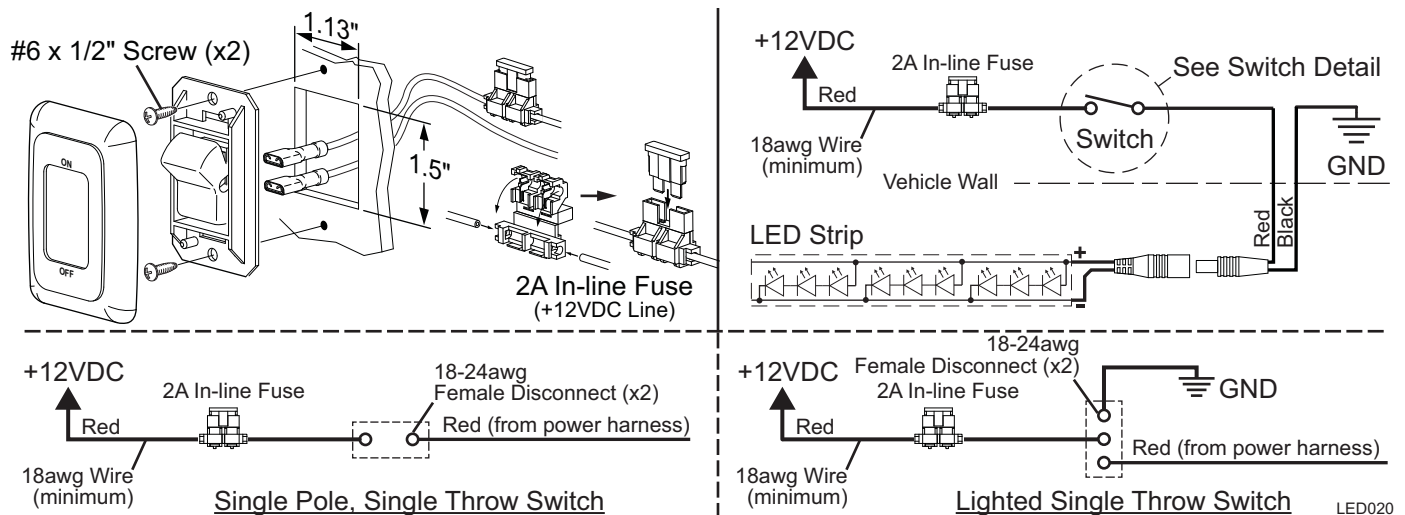

- Determine the location of the switch.
- At the switch location, cut a 1 1/8" x 1 1/2" hole.
- Wire the switch as shown below. Wire terminals at the switch are .187, 18-24 awg female disconnects.

NOTE: Allow adequate slack in the 12VDC power line so that the in-line fuse (installed in step 4) can be accessed from behind the switch.
- Install the in-line fuse:
 - Near the switch, cut the red 12VDC power line to the switch. Do not strip the insulation.
 - Insert a wire end into one of the wire channels until it butts up against the stop.
 - Fold that half of the connector body over until the element contacts the wire. Use pliers to crimp the connector closed.
 - Repeat for the second wire end.
 - Slide the fuse into the fuse port. Ensure that is firmly seated.
- Press the in-line fuse, wires and switch into the mounting hole. Secure the switch using two (2) #6 x 1/2" screws.
- Snap the switch bezel over the switch frame.

POWER CONNECTION FOR OPTIONAL OEM RGB LED'S

The RGB LED uses a receiver and remote (SR0109).

NOTES:

- The installation requires that the power line (+12VDC) be attached to a dedicated 2A circuit breaker or a 2A in-line fuse must be installed between the control module and power source. Locate the fuse for easy access. Fuse and connector are furnished by the installer.
- Per RVIA Low Voltage Systems in Conversion and Recreation Vehicles Chapter 3, Section 3-1: For Carefree LED strip lighting near the awning rail: when the 24AWG power harness is spliced or connected 10" or less from the harness connector using a heavier gauge wire, the fuse size is determined by the heavier wire gauge.

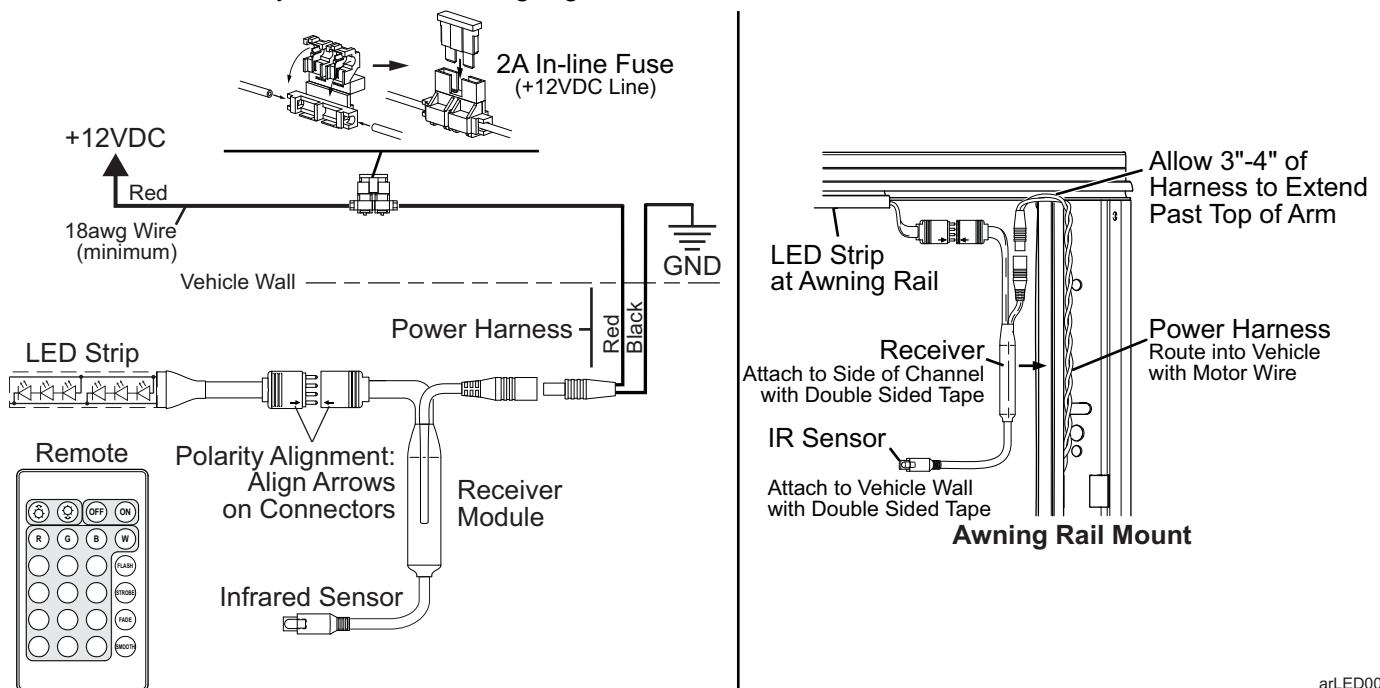

- Route the power cable into the vehicle with the motor cables from the awning.
- Route the Red wire to +12Vdc.
- Route the Black wire to ground.
- Ensure that the connections are tight, solid and sealed when completed.
- For awning rail applications:
 - Mount the control module and RF sensor on the outside of the vehicle as shown using double sided tape.
 - Connect the module wires to the power harness and LED strip.

NOTE: The LED connector and receiver connectors must be oriented with the arrows on the connectors lined up. The lights will not work if the connectors are not properly oriented.

arLED005