



OEM INSTALLATION MANUAL

ASCENT AND ASCENT XL

RV

SLIDE-OUT COVER WITH SLAT



Read this manual before installing or using this product. Failure to follow the instructions and safety precautions in this manual can result in personal injury and/or cause the product to not operate properly.

This manual contains installation instructions for the Ascent (units for room widths 197" or less) and the Ascent XL (units for room widths greater than 197").

The slat option is available as an OEM option only.

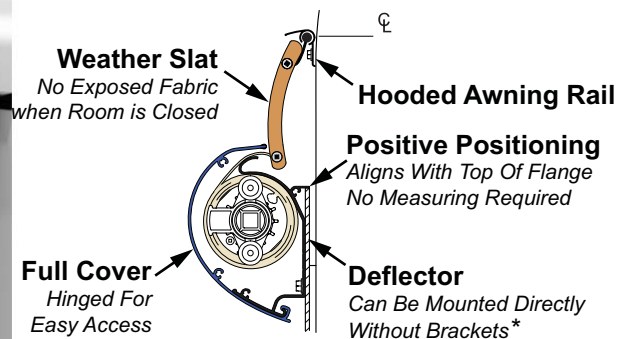

* An optional mounting bracket is available for curved flange applications or applications that the deflector cannot be mounted directly.

as001c

- Stylized to blend smoothly with the coach wall;
- Simplified installation, deflector mounts directly to room and aligns with the top of the room flange;
- Improved pitch provides for rain run off;
- Hinged cover provides easy access for cleaning and service while providing a closed, finished appearance;
- Weather slat eliminates billowing. When the room is closed, no fabric is exposed;
- Available in standard and XL versions.

PROPRIETARY STATEMENT

The Ascent Slide-Out cover is a product of Carefree of Colorado, located in Broomfield, Colorado, USA. The information contained in or disclosed in this document is considered proprietary to Carefree of Colorado. Every effort has been made to ensure that the information presented in the document is accurate and complete. However, Carefree of Colorado assumes no liability for errors or for any damages that result from the use of this document.

The information contained in this manual pertains to the current configuration of the models listed on the title page. Earlier model configurations may differ from the information given. Carefree of Colorado reserves the right to cancel, change, alter or add any parts and assemblies, described in this manual, without prior notice.

Carefree of Colorado agrees to allow the reproduction of this document for use with Carefree of Colorado products only. Any other reproduction or translation of this document in whole or part is strictly prohibited without prior written approval from Carefree of Colorado.

SAFETY INFORMATION



This is the safety alert symbol. It is used to alert individuals to potential personal injury hazards. Obey all safety messages that follow this symbol to avoid possible personal injury or death.



Indicates a hazardous situation, which if not avoided, could result in death or serious bodily injury.



Indicates a hazardous situation, which if not avoided, may result in minor or moderate bodily injury.



Indicates a situation that may result in equipment-related damage.

General Safety:



This product can expose you to chemicals including Di-isodecyl phthalate (DIDP), Vinyl Chloride and Formaldehyde, which are known to the state of California to cause cancer or birth defects or other reproductive harm. For more information visit www.P65warnings.ca.gov



Shock Hazard. Always disconnect battery or power source before working on or around the electrical system.



Always wear appropriate safety equipment (i.e. goggles).



Always use appropriate lifting devices and/or helpers when lifting or holding heavy objects.



When using fasteners, do not over tighten. Soft materials such as fiberglass and aluminum can be "stripped out" and lose the ability to grip and hold.

TABLE OF CONTENTS

Preliminary Layout - All Models 2
 Option 1 - Direct Mount of Deflector2
 Option 2 - Deflector Mount w/ Brackets2
 Mounting the Awning Rail3

Installation – Ascent and Ascent XL (up to 353") 4
 Component Checklist.....4
 Unpacking the Unit4
 Installing the Deflector - Option 1, Direct Mount5
 Installing the Deflector - Option 2, w/ Brackets6
 Installing the Roller tube Assembly.....7
 Installing the Front Cover.....8

Installation - Ascent XL, 354" and Longer 10
 Component Checklist.....10
 Installing the Deflector - Option 1, Direct Mount11
 Installing the Deflector - Option 2, w/ Brackets12
 Installing the Roller tube Assembly.....13
 Assembling the Roller Tube and Fabric13
 Mounting the Slat14
 Inserting the Soft Connect.....14
 Mounting the Roller Tube Assembly15
 Installing the Front Cover.....16

PRODUCT OVERVIEW

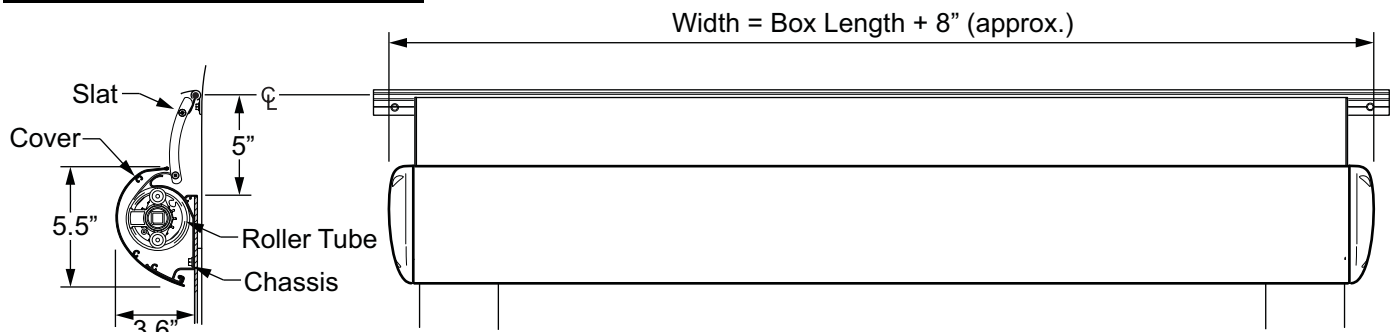

Dimensions are approximate, actual dimensions may vary based on the slide-out configuration and if optional mounting brackets are used.

as029

Figure 1. General Dimensions.

AVAILABLE LENGTHS: (measured box length)	Standard 42" - 197" XL 198" - 384"	AVAILABLE EXTENSION: Up to 42"
Pitch:	5° @ 42" extension (pitch increases as extension decreases)	
FABRIC TENSION	One spring for standard widths; Two springs for XL models	
COLOR:	<i>Hardware:</i>	White, Black
	<i>Fabric:</i>	Woven Acrylic, Polyweave and Vinyl (refer to sales literature for available colors)
WEIGHT:	<i>Standard</i>	Base Weight @ 42" Box Length = 22.2 lbs; for every 12" increase, add 3.6 lbs
	<i>XL</i>	Base Weight @ 197" Box Length = 75.2 lbs; for every 12" increase, add 3.6 lbs

Weight calculation is approximate. Actual weight may vary based on type of canopy fabric and specific installation details

PRELIMINARY LAYOUT - ALL MODELS

Two options are available to install the deflector. *Option 1* mounts the case directly to the flange and face of the room. *Option 2* uses mounting brackets for the deflector. This option is used when the coach has a curved flange or when the measurement of the top of room to top of flange height exceeds the 2.7" maximum for direct mounting.

NOTE: Dimensions are shown with the room CLOSED. These dimensions apply to all room styles including drop-down rooms.

OPTION 1 - DIRECT MOUNT OF DEFLECTOR

Top of room to top of flange:
2.7" maximum.

Clearance Envelope:
Protrusions such as moldings cannot extend more than .38" beyond the face of the flange or be higher than 3" from the top of the flange.

Top of flange to centerline awning rail:
5" ± .25" along surface of coach wall.

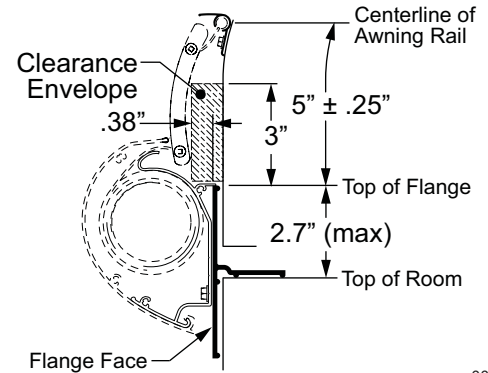

Figure 2. Direct Mount of Deflector.

OPTION 2 - DEFLECTOR MOUNT W/ BRACKETS

The illustrations show the minimum and maximum tolerances for installing the brackets and awning rail.

Top of room to top of flange:
4.5" maximum.

The bracket must be positioned to meet the following:
Bottom of bracket to top of room: 1" minimum
Bottom of bracket to top of flange: 5.85" maximum

Maximum allowable flange thickness:
.94" measured from the mounting face to the outer most face of the flange.

Bottom of bracket to centerline awning rail:
10.88" ± .25" along surface of coach wall.

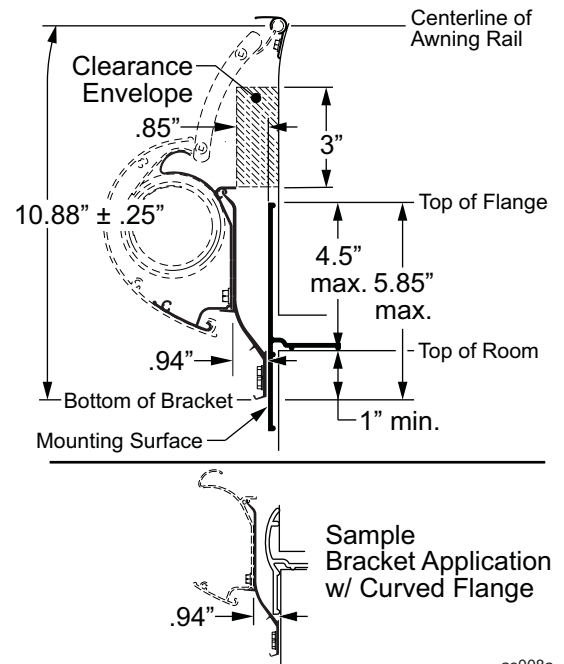

Figure 3. Deflector Mount w/ Bracket.

Vertical Positioning for Brackets

The following steps are suggested as a starting point for the bracket layout. The bracket position can be adjusted upward to best fit the application on condition that the bottom of the bracket falls within the limits given above. Please note that both the bracket and awning rail must move an equal amount.

1. From the top of the flange, measure 5.75" down on the face/flange of the room. Use a non-permanent method to mark this position. This will be the bottom of the bracket.
2. From the bottom of the bracket, measure 10.5" up along the surface of the coach. This will be the centerline of the awning rail.

MOUNTING THE AWNING RAIL

NOTES:

- a) The awning rail for the XL is shipped in two pieces.
 - b) Clean and deburr the mating ends of the rails so that there are no sharp edges at the joint.
 - c) When mounting the rails, make sure that the two pieces are aligned and straight.
 - d) The hooded awning rail included with the awning is required to prevent leaks next to the RV. Water leaks can occur if trying to use an existing rail or a standard style rail.
1. *For Option 1:* (Detail A) Mark the centerline of the awning rail $5" \pm .25"$ above the top edge of the room flange. (Detail A)
 2. *For Option 2:* (Detail B) Mark the centerline of the awning rail $10.88" \pm .25"$ from the bottom of bracket line (refer to "Vertical Positioning for Brackets" on page 2).
 3. Seal the back of the rail with silicone sealant or putty tape.
 4. Align the centerline of the awning rail and attach the rail using #10 x 3/4 screws.
- To aid sliding the soft-connect into position:*
5. (Detail C) Using a screwdriver slightly spread open one end of the awning rail.
 6. Clean and deburr the end of the rail.
 7. Spray inside the rail track with silicone lubricant.

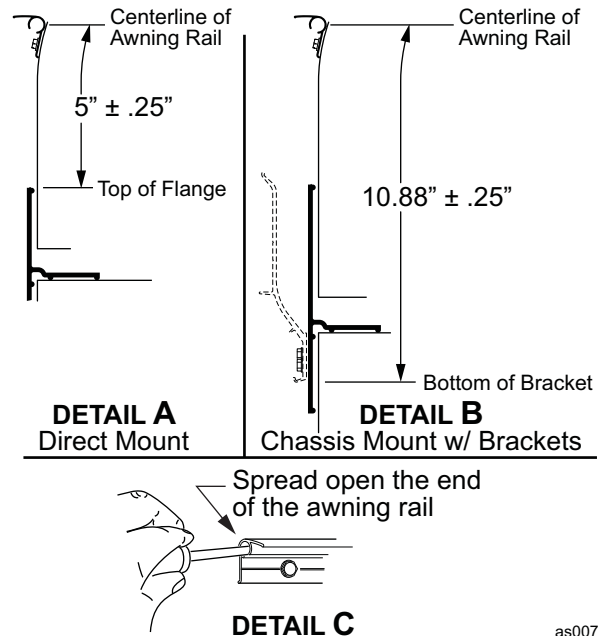

as007

If installing the **Ascent** or Ascent XL (up to 353"), go to **page 4**, "Installation - Ascent".

If installing the **Ascent XL** with lengths 354" or longer, go to **page 10**, "Installation - Ascent XL, 354" and longer".

INSTALLATION – ASCENT AND ASCENT XL (UP TO 353")

COMPONENT CHECKLIST

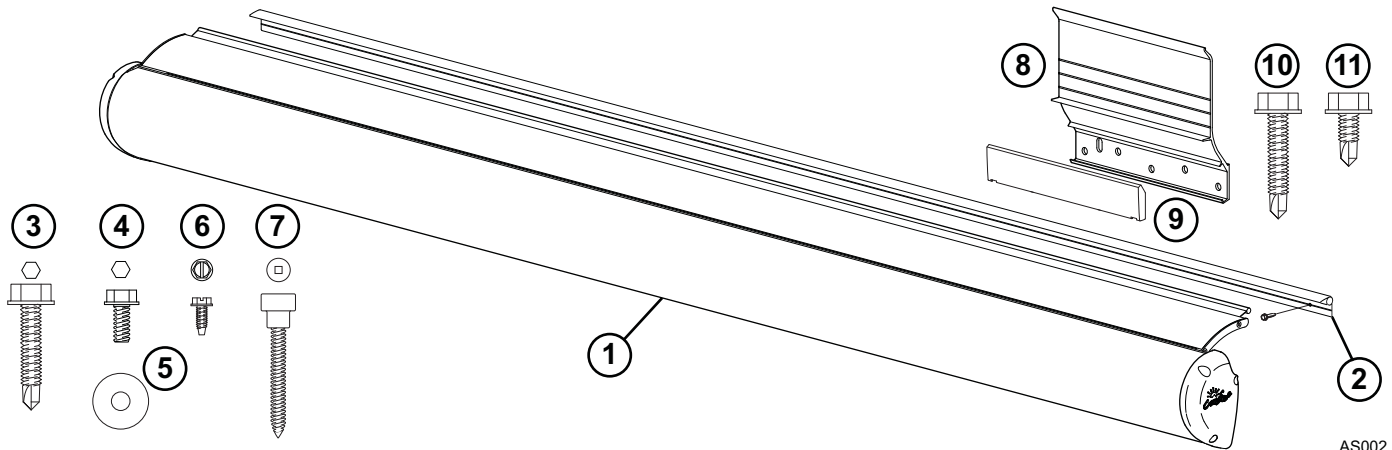

<input checked="" type="checkbox"/>	ITEM	DESCRIPTION		QTY	NOTE
<input type="checkbox"/>	1	Ascent Assy, Complete		1	
<input type="checkbox"/>	2	Awning Rail		1	2
<input type="checkbox"/>	3	Screw, Self Drilling	#12 x 1	NOTE	3
<input type="checkbox"/>	4	Screw, Washer Head, Thread Cutter	#10 x 3/8	2	
<input type="checkbox"/>	5	Fender Washer	#10	2	
<input type="checkbox"/>	6	Screw, Hex Head	#6 x 3/8	2	
<input type="checkbox"/>	7	Screw, Shoulder	#8 x 1 1/2	2	
<input type="checkbox"/>	8	Bracket, Deflector Mount		NOTE	4
<input type="checkbox"/>	9	Cover, Bracket		1	5
<input type="checkbox"/>	10	Screw, Self Drilling	#12 x 1	5	5
<input type="checkbox"/>	11	Screw, Self Drilling, TEK	#12 x 1/2	3	5

- NOTES:
- Product configuration is specified at time of order, including length, fabric, color etc. Check assembly against original purchase order.
 - The hooded awning rail is required for Ascent installations to prevent leakage next to the RV. For Ascent XL, awning rail is shipped in two pieces. Screws are included with rail, quantities are based on rail length.
 - Quantity for screw (item 3) is determined by length of awning ordered.
 - Bracket (item 8) is specified at time of order. For lengths 42" - 114", qty = 2; for lengths 115" - 197", qty = 3; for lengths 198" – 289, qty = 4; for lengths 290 and longer, qty = 5.
 - Quantities for cover (item 8) and screws (items 9, 10) are per bracket.

UNPACKING THE UNIT

The Ascent is shipped partially assembled. For installation, it will be necessary to separate the components.

- Remove the packing wrap.
- Lift the cover up and set aside.
- From one end, loosen the end cap screws approximately one inch. It is not necessary to remove the screws completely.
- Slide the end cap away from the deflector.
- Carefully pull and lift the roller tube assembly out of the fixed end cap and set aside. The assembly includes roller tube, fabric, slat and soft-connect.

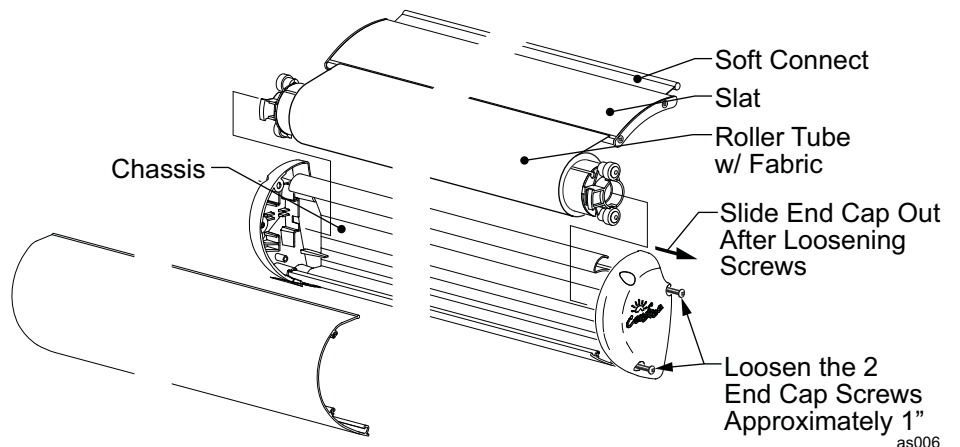

Figure 4. Unpacking the Unit.

If closed, open the room approximately 3 inches. If open, close the room to approximately 3 inches.

NOTICE DO NOT attempt to open or close the room further until all steps are complete, including "Installing the Front Cover" on page 8.

INSTALLING THE DEFLECTOR - OPTION 1, DIRECT MOUNT

The following instructions reference the preliminary layout done previously. Refer to "Option 1 - Direct Mount of Deflector" on page 2.

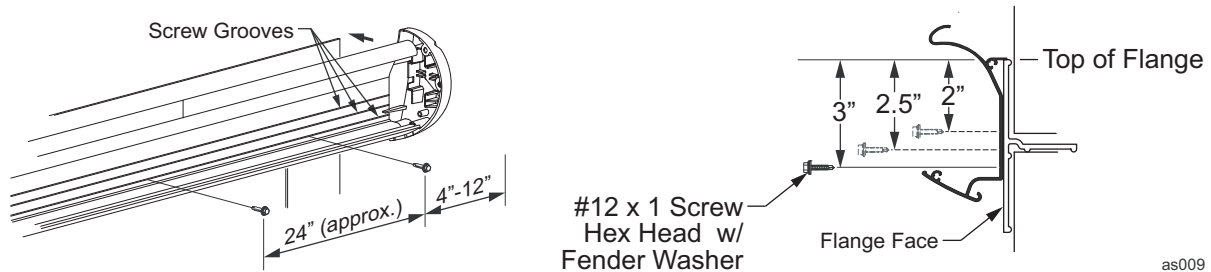

Figure 5. Installing the Deflector.

1. Lift the deflector up and set the rear protrusion on top of the flange as shown. Horizontally center the case on the room.
2. Attach the case to the room face using the #12 x 1 self-drilling screws. Attach the ends first placing the screws 4"-12" from the end of the case AND into structure. Continue to attach by evenly spacing screws between the ends approximately 24" apart.

NOTE:

- **Three screw groove guides are scribed into the case. Use the groove that best matches the room's structure.**
 - **Before tightening the screw, seal the hole and head of the screw with a quality silicone sealant.**
3. Thoroughly clean any shavings and debris from the case before proceeding to the next step.

INSTALLING THE DEFLECTOR - OPTION 2, w/ BRACKETS

The following instructions reference the preliminary layout done previously. Refer to "Option 2 - Case Mount w/ Brackets" on page 2.

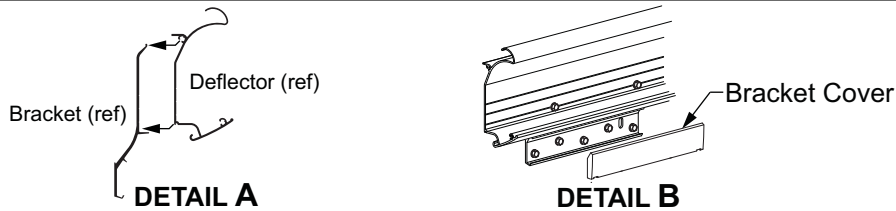
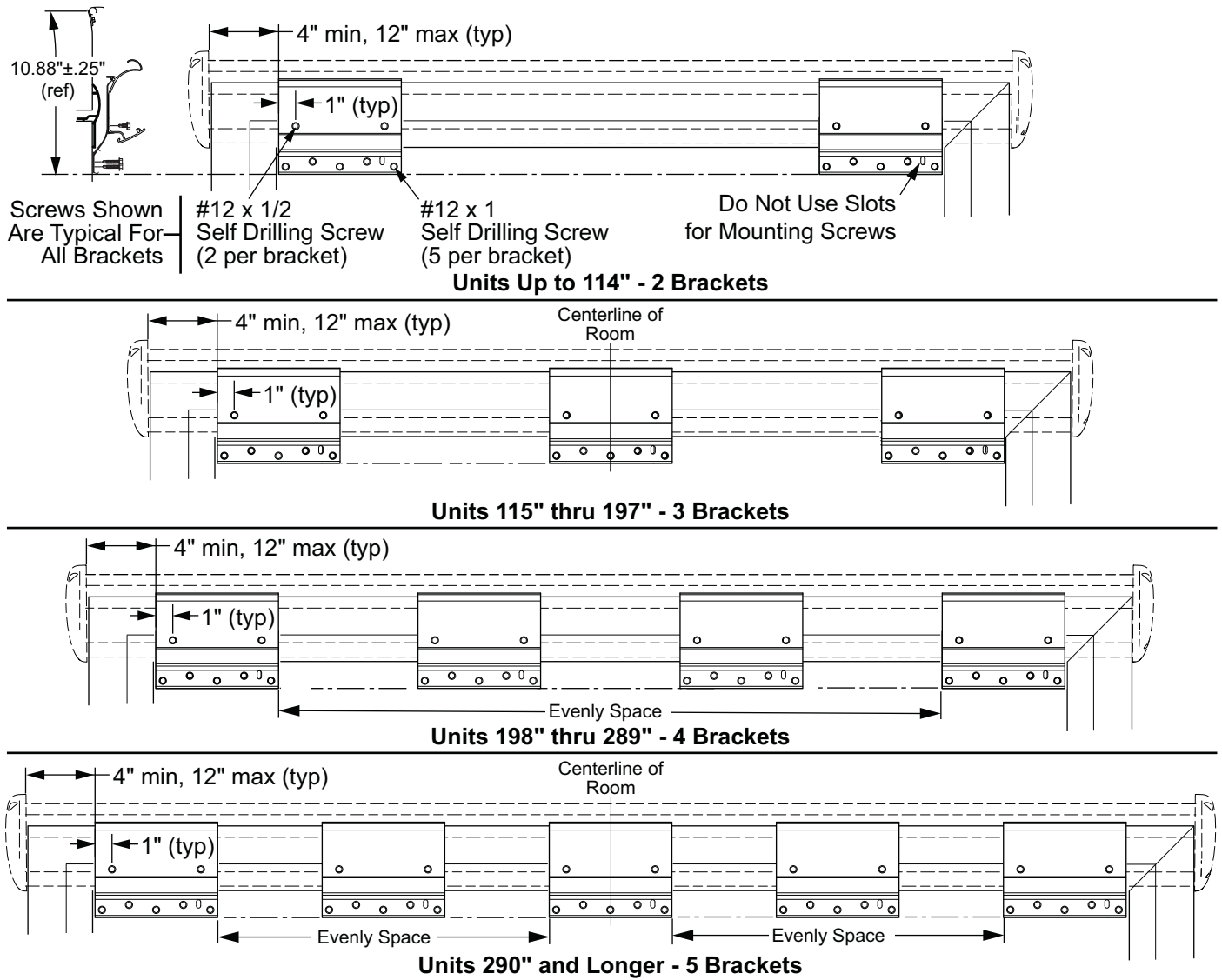

as011

Figure 6. Mounting the Deflector w/ Brackets.

1. Position the brackets on the room face as shown.
For rooms with box lengths 42" - 114", qty = 2; for lengths 115" - 197", qty = 3; for lengths 198" - 289", qty = 4; for lengths 290" and longer, qty = 5.
2. Using a quality silicone sealant, coat the mounting surface of the bracket with particular attention around the mounting holes.
3. Attach the bracket using five (5) #12 x 1 self-drilling screws each. The slot is not for a mounting screw.
4. (Detail A) Lift and set the groove in the back of the deflector onto the hook of the brackets.
5. Horizontally center the case over the room.

- In the lowest screw groove, attach the deflector to the brackets using the #12 x 1/2 self-drilling TEK screws (3 per bracket).
- Thoroughly clean any shavings and debris from the case before proceeding to the next step.
- Snap the bracket cover onto the bracket to cover the screw heads. The tab on the back of the cover goes into the slotted hole of the bracket.

NOTE: If it is necessary to remove the cover after installation, slide a small pin (e.g. paper clip) in the end under the cover. Lift the locking tab and gently pull out the end of the cover. Repeat for other side of the cover.

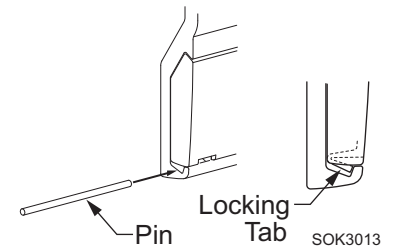

Figure 7. Removing the Cover.

INSTALLING THE ROLLER TUBE ASSEMBLY

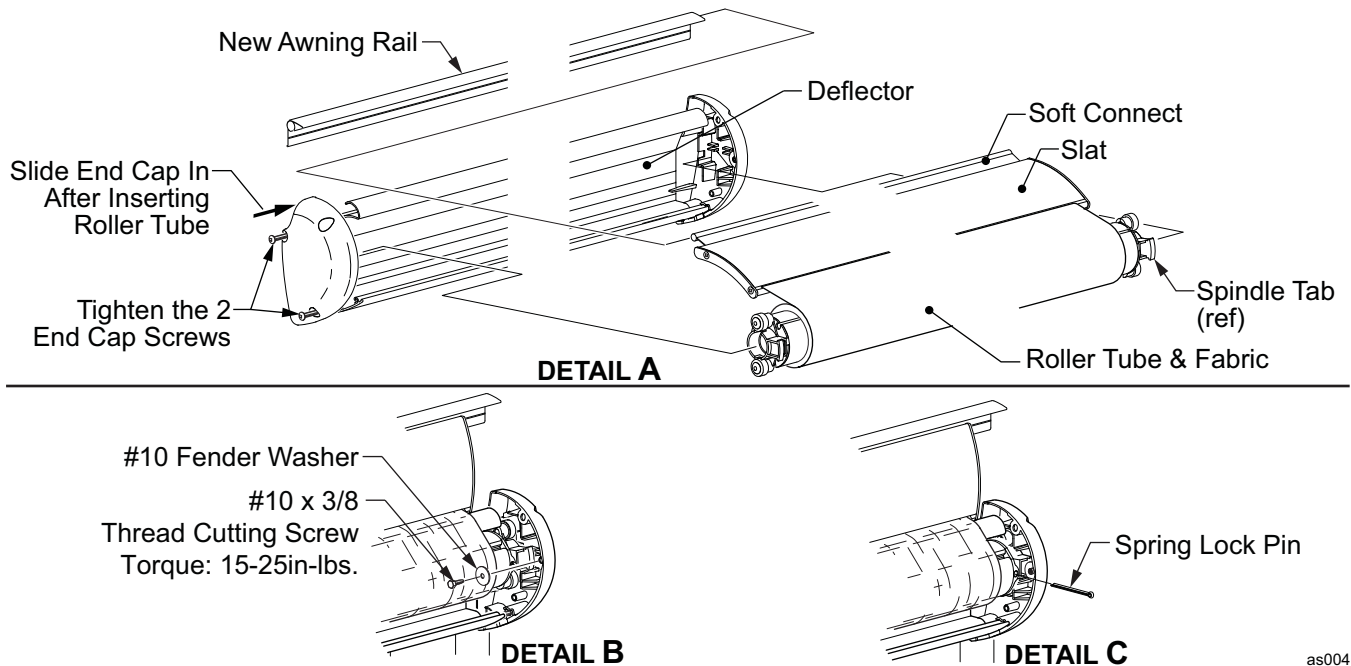

Figure 8. Installing the Roller tube Assembly.

CAUTION Do not remove the spring locking pin until instructed after all steps are complete.

- If not previously done, from one end, loosen the end cap screws approximately one inch. It is not necessary to remove the screws completely.
- Lift the roller tube assembly up and slide the soft connect poly rod into the awning rail. Center the fabric over the room
- Roll up any slack material onto the roller tube.
- Insert the roller tube into the fixed end cap. Note the orientation of the spindle tabs at the ends of the roller tube; these must point forward (away from coach).
- Align the spindle with the loose cap then push the loose end cap onto the roller tube and against the deflector. Tighten the screws.
- (Detail B) Inside each end cap, screw in the #10 x 3/8 thread-cutter screw and fender washer as shown. Torque screws 15-25 in-lbs.

CAUTION The roller tube has a pre-wound spring. When the spring lock pin is removed, the roller tube spring will quickly roll up any slack material. Use care that hands and fingers are out of the way.

- (Detail C) Remove the spring locking pin from the end of the roller tube assembly. This is located on the right end of the roller tube.

INSTALLING THE FRONT COVER

If closed, open the room approximately 3 inches. If open, close the room to approximately 3 inches.

CAUTION DO NOT attempt to open or close the room further until the front cover is installed and attached.

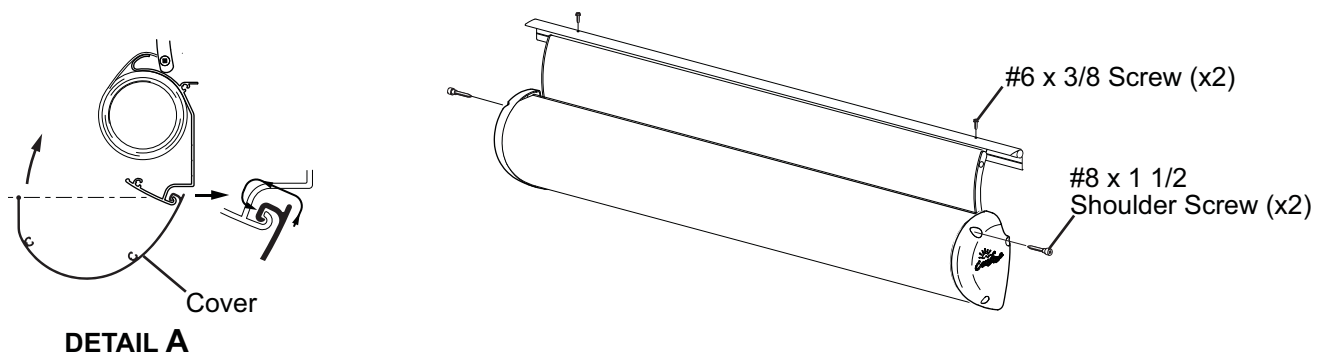

as010

Figure 9. Installing the Cover.

1. Holding the cover perpendicular to the deflector, lift and hook the cover onto the back of the case (refer to Detail A).
2. Rotate the cover up and secure using two (2) #8 x 1 1/2 shoulder screws. To properly position the cover it will be necessary to press the cover toward the slat until the attach holes align with end cap holes.

NOTE: There will be a small gap between the cover and end cap. DO NOT attempt to close the cap by over tightening the screw, maximum torque is 30 in-lbs.
3. Open and close the room to confirm that the fabric is rolling up straight on the roller tube. If necessary, adjust the position of the soft connect in the awning rail until the fabric rolls up correctly.
4. Secure the soft connect to the awning rail using two (2) #6 x 3/8 screws through the top of the rail and polyrod/fabric.

INSTALLATION - ASCENT XL, 354" AND LONGER

COMPONENT CHECKLIST

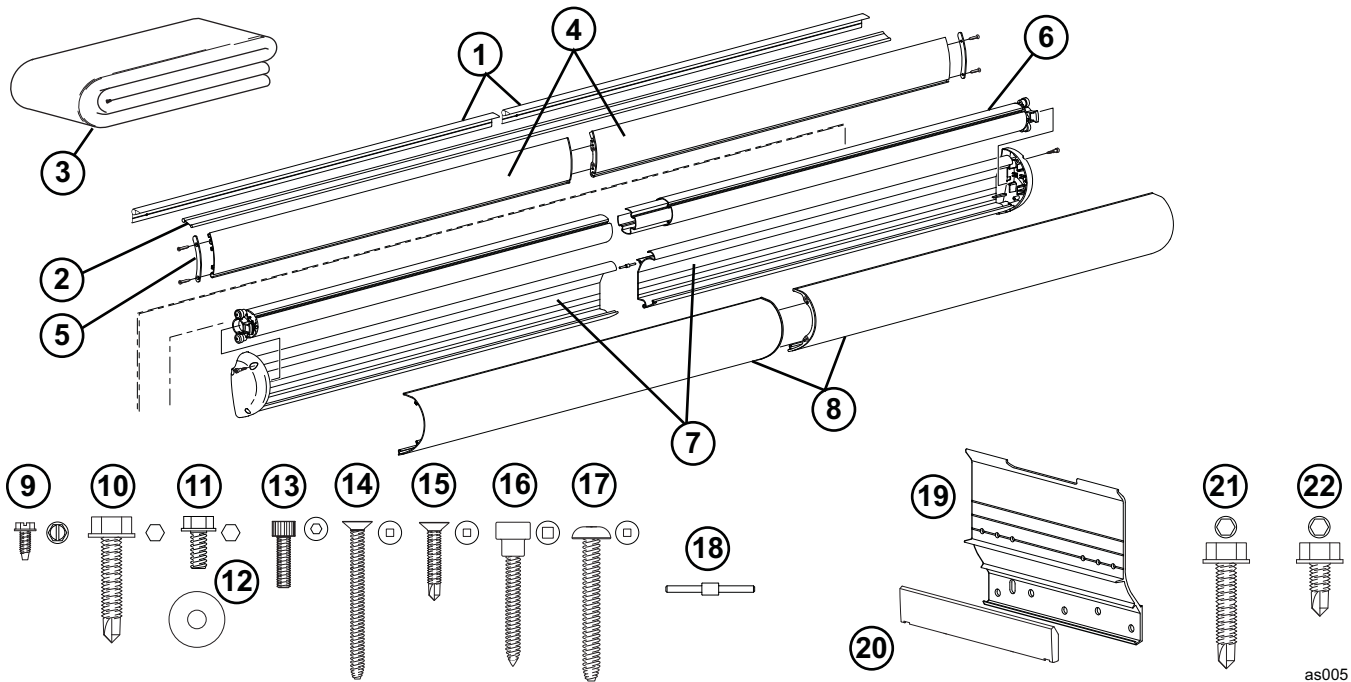

<input checked="" type="checkbox"/>	ITEM	DESCRIPTION	QTY	NOTE
<input type="checkbox"/>	1	Awning Rail	1	2
<input type="checkbox"/>	2	Soft Connect	1	
<input type="checkbox"/>	3	Fabric	1	
<input type="checkbox"/>	4	Slat Assy	1	3
<input type="checkbox"/>	5	End Plate, Slat	(1 LH and 1 RH)	2
<input type="checkbox"/>	6	Roller Tube Assy	1	3
<input type="checkbox"/>	7	Deflector Assy	1	3
<input type="checkbox"/>	8	Cover Assy	1	3
<input type="checkbox"/>	9	Screw, Hex Head	#6 x 3/8	2
<input type="checkbox"/>	10	Screw, Self Drilling	#12 x 1	NOTE 4
<input type="checkbox"/>	11	Screw, Hex Washer Head, Thread Cutter	#10 x 3/8	2
<input type="checkbox"/>	12	Fender Washer	#10	2
<input type="checkbox"/>	13	Screw, Socket Head Cap Screw	#8-32 x 1/2	4
<input type="checkbox"/>	14	Screw, Flat Head, Square Drive	#8 x 2	4
<input type="checkbox"/>	15	Screw, Flat Head, Square Drive, Self Drilling	#8 x 3/4	4
<input type="checkbox"/>	16	Screw, Shoulder	#8 x 1 1/2	2
<input type="checkbox"/>	17	Screw, Pan Head, Square Drive	#8 x 2	2
<input type="checkbox"/>	18	Spacer, Shouldered		1
<input type="checkbox"/>	19	Bracket, Deflector Mount		5 5
<input type="checkbox"/>	20	Cover, Bracket		5
<input type="checkbox"/>	21	Screw, Self Drilling	#12 x 1	25
<input type="checkbox"/>	22	Screw, Self Drilling, TEK	#12 x 1/2	10

- NOTES:
- Product configuration is specified at time of order, including length, fabric, color etc. Check assembly against original purchase order.
 - Screws are included with rail; quantity is based on length of rail. Awning rail is shipped in two pieces.
 - Slat assy (item 4), roller tube assy (item 6), deflector (item 7) and cover (item 8) are shipped in two sections and must be assembled during installation.
 - Quantity for item 3 screw is determined by length of awning ordered.
 - Bracket (item 19) is specified at time of order. Cover (item 20) and screws (items 21, 22) come with brackets.

If closed, open the room approximately 3 inches. If open, close the room to approximately 3 inches.

CAUTION THE **DO NOT** attempt to open or close the room further until all steps are complete, including "Installing the Front Cover" on page 16.

INSTALLING THE DEFLECTOR - OPTION 1, DIRECT MOUNT

The following instructions reference the preliminary layout done previously. Refer to "Option 1 - Direct Mount of Deflector" under Preliminary Layout on page 2.

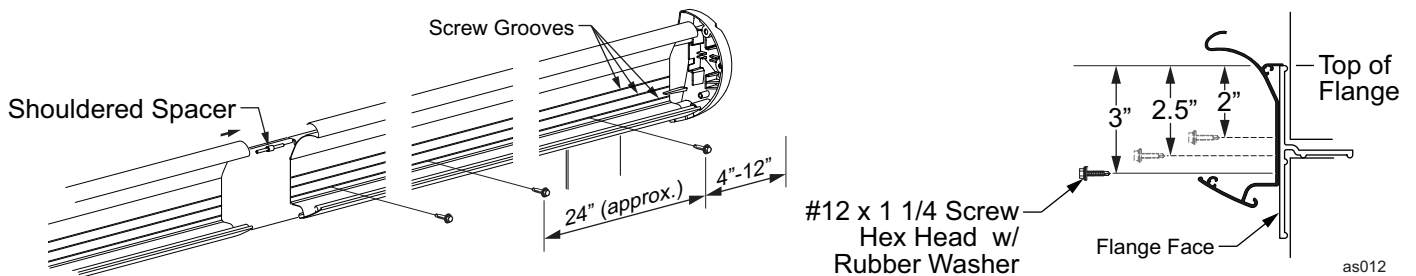

Figure 10. Installing the Deflector.

1. Measure and mark the center of the room flange.
2. Lift one of the deflector halves up and set the rear protrusion on top of the flange as shown. Align the inner edge of the deflector half with the mark made in step 1.
3. Attach the deflector to the room face using the #12 x 1 1/4 self-drilling screws w/ rubber washer.
 - Attach the ends first placing the screws 4"-12" from the end of the deflector AND into structure.
 - *For box lengths less than 96"*: Continue to attach by evenly spacing 3 additional screws between the ends. Use a minimum number of 5 screws to attach the deflector.
 - *For box lengths longer than 96"*: Continue to attach by evenly spacing screws between the ends approximately 24" apart.

NOTES:

- **Three screw groove guides are scribed into the deflector. Use the groove that best matches the room's structure.**
 - **Before tightening the screw, seal the hole and head of the screw with a quality silicone sealant.**
4. Slide the shouldered spacer into the rear screw slot of the deflector.

IMPORTANT NOTE: The spacer must be between the deflector halves as shown. Failure to do so will cause the other components (i.e. roller tube and cover) to not fit properly.
 5. Lift the second deflector half up and slide onto the shouldered spacer. Position on the flange and attach in the same manner as the first deflector half.
 6. Thoroughly clean any shavings and debris from the deflector before proceeding to the next step.

INSTALLING THE DEFLECTOR - OPTION 2, W/ BRACKETS

The following instructions reference the preliminary layout done previously. Refer to "Option 2 - Deflector Mount w/ Brackets" under Preliminary Layout on page 2.

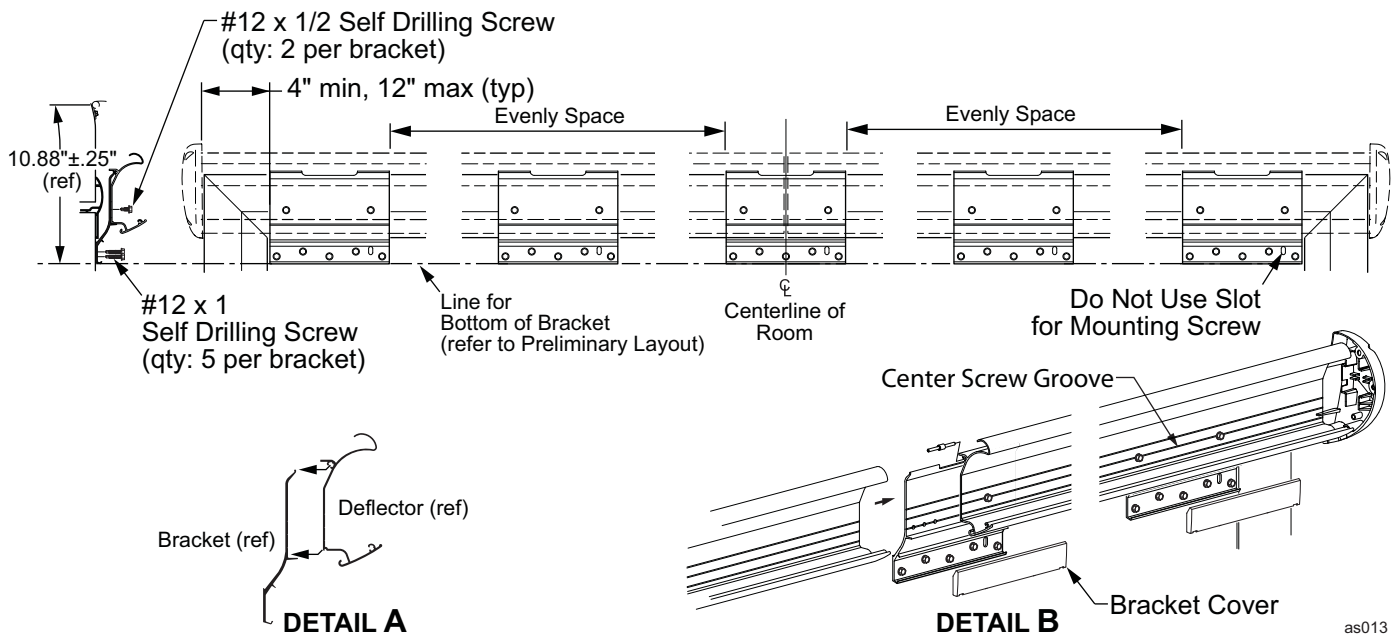

Figure 11. Mounting the Deflector w/ Brackets.

1. Position the deflector brackets on the room face as shown. The center bracket must be positioned so that the center splice of the deflector will rest near the center of the bracket. The middle brackets may be adjusted $\pm 12"$ to avoid vents or other projections.
 2. Using a quality silicone sealant, coat the mounting surface of the bracket with particular attention around the mounting holes.
 3. Attach the brackets using five (5) #12 x 1 self-drilling screws each. The slot is not for a mounting screw.
 4. Measure and mark the center of the room flange.
 5. (Detail A) Lift and set the groove in the back of the first deflector half onto the hook of the brackets. Align the inner edge of the deflector half with the mark made in step 4.
 6. In the lowest screw groove, attach the deflector to the brackets using the #12 x 1/2 self-drilling TEK screws (3 for the outer brackets, 1 for the center bracket).
 7. (Detail B) Slide the shouldered spacer into the rear screw slot of the deflector.
- IMPORTANT NOTE:** The spacer must be between the deflector halves as shown. Failure to do so will cause the other components (i.e. roller tube and cover) to not fit properly.
8. Lift the second deflector half up and slide onto the shouldered spacer. Position on the brackets and attach in the same manner as the first deflector half.
 9. Snap the bracket cover on to the bracket to cover the screw heads. The tab on the back of the cover goes into the slotted hole of the bracket.

NOTE: If it is necessary to remove the cover after installation, slide a small pin (e.g. paper clip) in the end under the cover. Lift the locking tab and gently pull out the end of the cover. Repeat for other side of the cover.

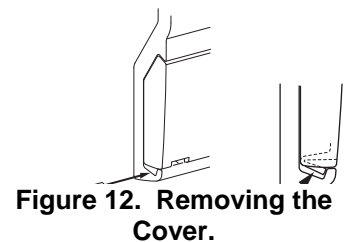

Figure 12. Removing the Cover.

INSTALLING THE ROLLER TUBE ASSEMBLY

CAUTION Do not remove the spring locking pins until instructed when all steps are completed.

Assembling the Roller Tube and Fabric

The roller tube is shipped in two pieces. The splice for the roller tube is attached in the end of the right roller tube.

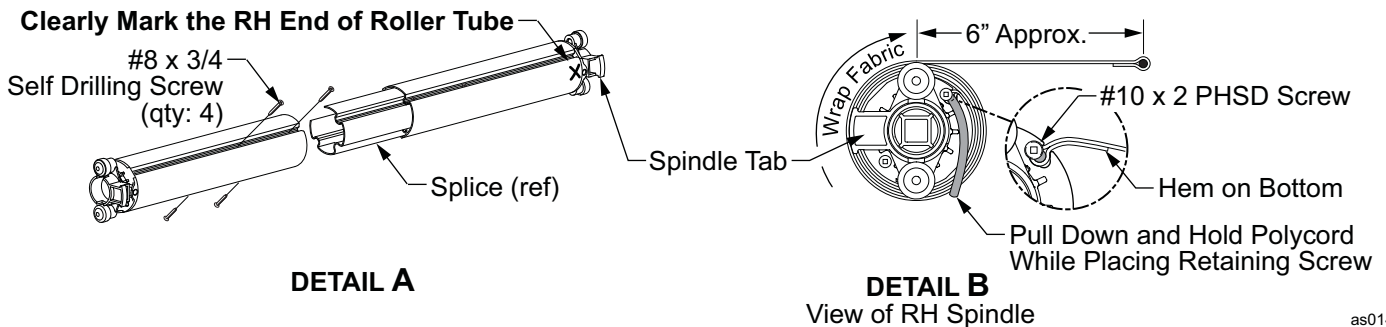

Figure 13. Assembling the Roller Tube.

1. Clearly mark the RH roller tube next to the bearing and spindle.
2. On the ground, press the two roller tube halves tightly together. The splice can only fit one way in the tube. For reference, the spindle tabs on the roller tube must both point in the same direction.
3. (*Detail A*) Attach the left tube half to the splice using four (4) #8 x 3/4 self-drilling screws. Match the screw pattern in the right roller tube half.
4. Slide the black polycord of the fabric into the fabric slot located on the opposite side of the spindle tabs. Orient the fabric with the hem on the bottom (the hem will then roll against the roller tube). Center the fabric in the roller tube.
5. (*Detail B*) After the fabric is centered, pull and hold the excess polycord in the bottom of the fabric slot. Place one (1) #10 x 2 PHSD screw through the fabric slot hole and polycord. The screw must be positioned to thread into the metal of the roller tube slot and the edge of the polycord. The screw action will pull the polycord further into the slot hole. DO NOT OVERTIGHTEN.
6. After the screw is installed, trim the excess polycord.
7. After tightening the fabric in the slot from one end of the roller tube to the other end, repeat step 5 and 6 to secure the fabric.
8. Roll the fabric onto the roller tube. Note the direction of the wrap as shown in Detail B. The view is of the RH spindle that was marked earlier. It is necessary to allow approximately 6" of fabric to extend past the roller tube.

Mounting the Slat

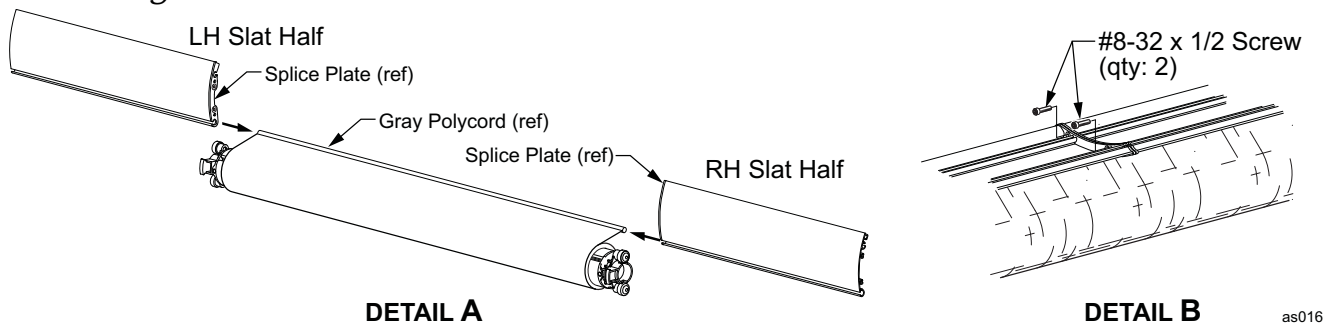

Figure 14. Mounting the Slat.

9. From each side, slide the slat halves onto the fabric. Use the slot in the front of the slat. Note that the splice plates go to the center of the fabric.
10. Lay the slat face down on the roll bar to expose the backside of the slat.
11. Push the two center splice plates together; attach the two slat halves using two (2) #8-32 x 1/2 screws.

NOTE: To prevent damage to the slat, use a ballpoint hex drive bit with a long extension. This will allow the screws to be tightened using a power driver.
12. Center the slat with the fabric.

Inserting the Soft Connect

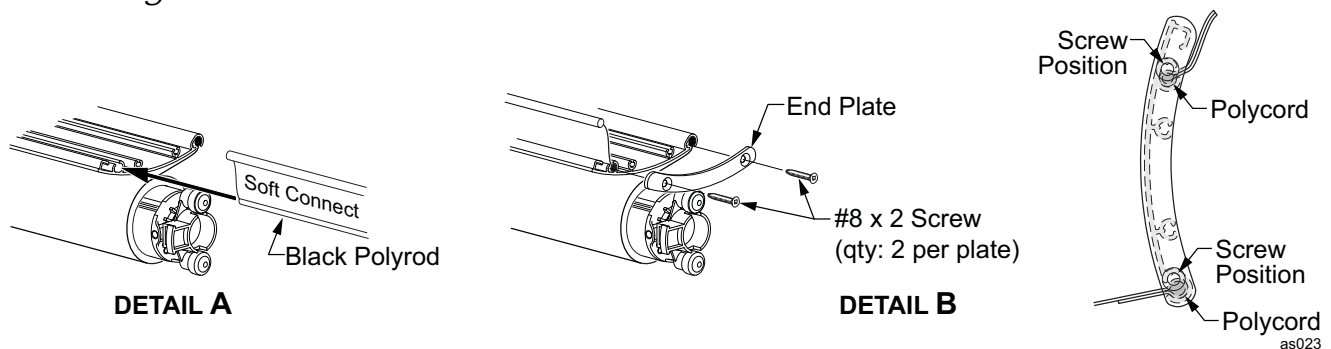

Figure 15. Inserting the Soft Connect.

13. Slide the soft connect into the rear slot of the slat (black polyrod).
14. Align one end of the soft connect in the slat. Trim any excess polyrod that extends past the slat.
15. (Detail B) After the material is positioned in the slat, align one end plate and attach to the slat using two (2) #8 x 2 flat head screws. **DO NOT OVER TIGHTEN.** The screws secure the soft connect, fabric and end plate to the slat. **NOTE:** The slat end plates are made as LH and RH.

NOTE: The attaching screws are offset from the center of the polyrods. Ensure that the polyrod is positioned in the large diameter of the fabric slot. The screws thread into the extrusion and the top of the polyrod.

Tip: Place a small wedge (such as a small flat blade screwdriver) between the top of the fabric and the slot to hold the polyrod down to start the screw in the correct position. Use care to not damage the fabric.
16. After tightening the fabric in the slot from one end of the slat to the other end, trim any excess polyrod and soft connect material that extends past the slat. Align the second end plate and attach to the slat using two (2) #8 x 2 flat head screws. **DO NOT OVER TIGHTEN.**

Mounting the Roller Tube Assembly

NOTICE For the XL model this operation requires 3 people; one person for each end of the assembly and one in the center.

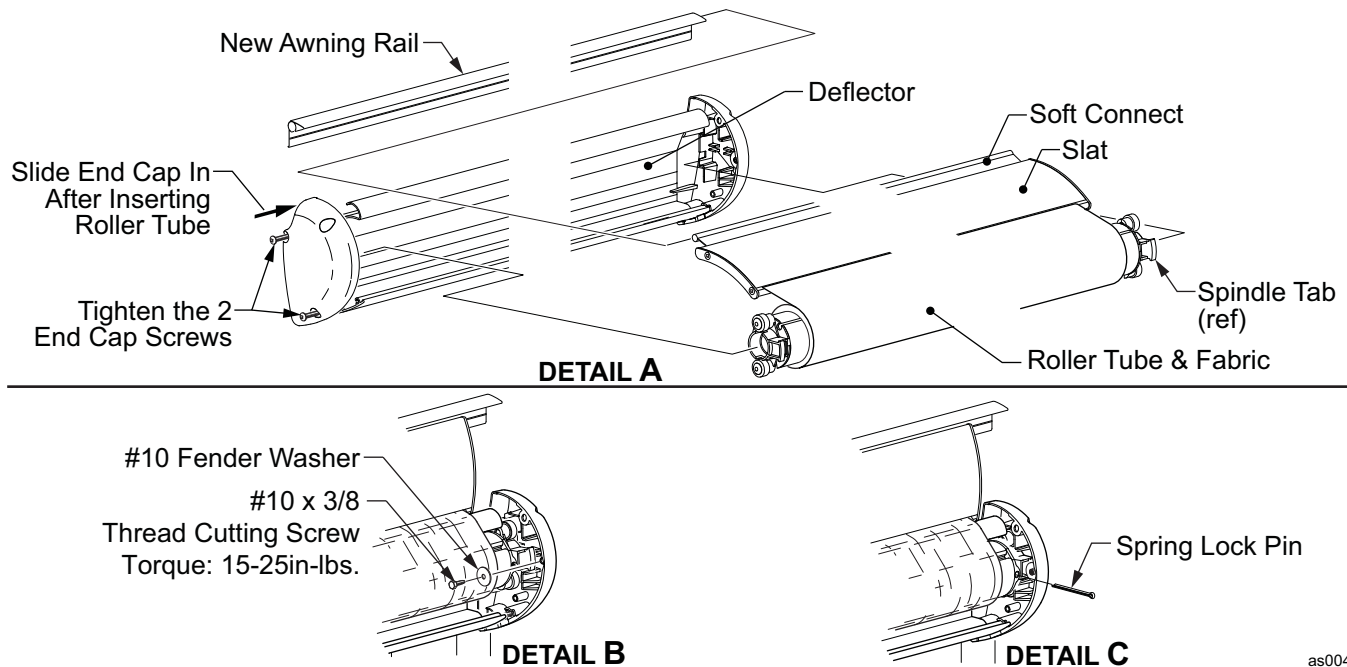

Figure 16. Mounting the Roller Tube Assembly.

If closed, open the room approximately 3 inches. If open, close the room to approximately 3 inches.

17. If not previously done, prepare the awning rail to accept the soft connect.
 - Using a screwdriver slightly spread open one end of the awning rail.
 - Clean and deburr the end of the rail.
 - Spray inside the rail track with silicone lubricant.
18. On one end of the deflector, back out the end cap screws approximately one inch. It is not necessary to remove the screws completely. Pull the end cap away from the deflector.
19. Lift the roller tube assembly up and slide the soft connect poly rod into the awning rail. Center the roller tube over the deflector.
20. Roll up any slack material onto the roller tube.
21. Insert the roller tube into the fixed end cap. Note the orientation of the spindle tabs at the ends of the roller tube; these must point forward (away from coach).
22. Align the spindle of the roller tube then push the loose end cap onto the roller tube and against the deflector. Tighten the screws.
23. (Detail B) Inside each end cap, screw in the #10 x 3/8 thread-cutter screw and fender washer as shown. Torque screws 15-25 in-lbs.

CAUTION The roller tube has two pre-wound springs. There is a spring locking pin on each end of the roller tube assembly. When the pins are removed, the roller tube springs will quickly roll up any slack material. Use care that hands and fingers are out of the way.

24. (Detail C) Remove the spring locking pin from each end of the roller tube assembly.

INSTALLING THE FRONT COVER

NOTICE DO NOT attempt to open or close the room until the front cover is installed, closed and fastened.

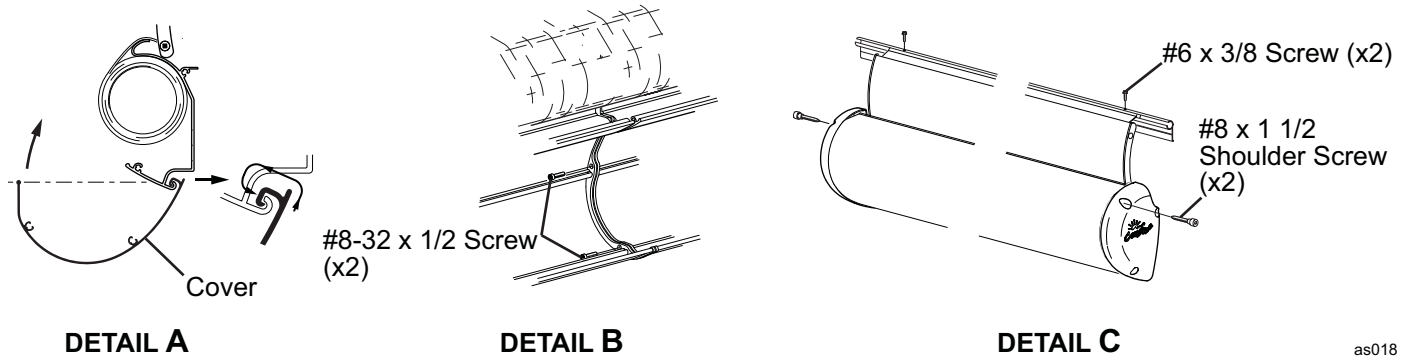

DETAIL B

DETAIL C

as018

Figure 17. Installing the Cover.

1. (Detail A) Holding one cover half perpendicular to the deflector, lift and hook the cover onto the back of the deflector. The splice plate should align with the center gap in the deflector.
2. Lift the second cover half up and hook onto the deflector.
3. (Detail B) Allow the two halves to hang down and align the splice plates. Attach the two halves using two (2) #8-32 x 1/2 screws.

NOTE: To prevent damage to the cover, use a ballpoint hex drive bit with a long extension. This will allow the screws to be tightened using a power driver.

4. (Detail C) Rotate the cover up and secure using two (2) # x 1 1/2 shoulder screws. To properly position the cover it will be necessary to press the cover toward the slat until the attach holes align with end cap holes.

NOTICE There will be a small gap between the cover and end cap. Do NOT attempt to close the cap by over tightening the screw, maximum torque is 30 in-lbs.

5. Open and close the room to confirm that the fabric is rolling up straight on the roller tube. If necessary, adjust the position of the soft connect in the awning rail until the fabric rolls up correctly.
6. Secure the soft connect to the awning rail using two (2) #6 x 3/8 screws through the top of the rail and polyrod/fabric.