



# ONE-Touch 12-VOLT PATIO AWNING AUTO-RETRACT & REMOTE CONTROL UPGRADE INSTRUCTIONS

**CONTAINS INSTALLATION AND OPERATING INSTRUCTIONS  
CUSTOMER MUST RECEIVE THIS MANUAL AFTER INSTALLATION  
FOR PROPER OPERATING PROCEDURES**

**USE THESE INSTRUCTIONS WHEN UPGRADING AN EXISTING  
ONE-TOUCH PATIO AWNING TO A ONE TOUCH WITH AUTOMATIC  
RETRACTION AND REMOTE CONTROL.**

## **SECTION ONE: INSTALLATION INSTRUCTIONS**

**REVIEW COMPONENTS BEFORE PROCEEDING**



**Control Module / Switch Panel**



**Remote Control Key Fob**

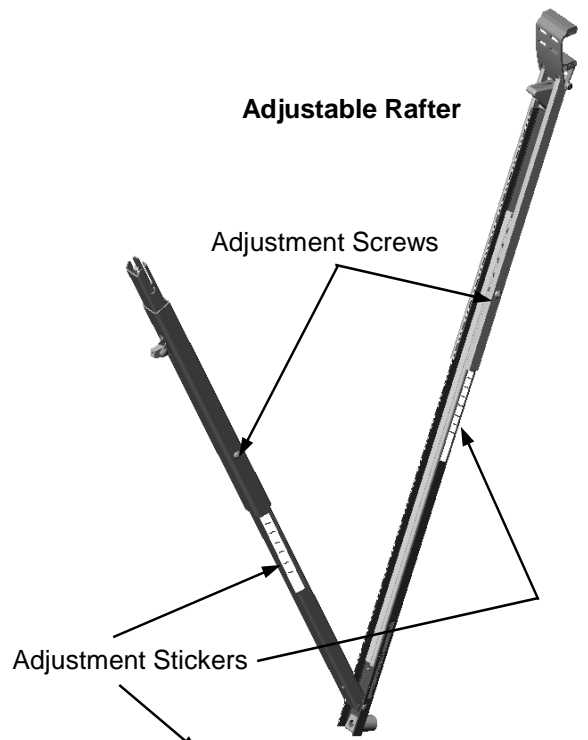

48" | 47" | 46" | 45" | 44" | 43" Adjust both connecting ends of the rafter to the same length. Remove this label after adjustment.

**Adjustable Rafter w/ Transmitter**

## Step One: Installing New Rafter

*The Upgrade to the Auto- Retract / Remote Control for the One-Touch requires that the back rafter be changed out. Follow the steps listed below to ensure proper rafter change.*

- A. Extend awning out too a point that there is only one wrap of fabric remaining around the roller assembly. (the valance slot will be facing almost straight up)
- B. Move to the back arm unscrew the gas shock from the shock bracket mounted on the rafter. (shown below)

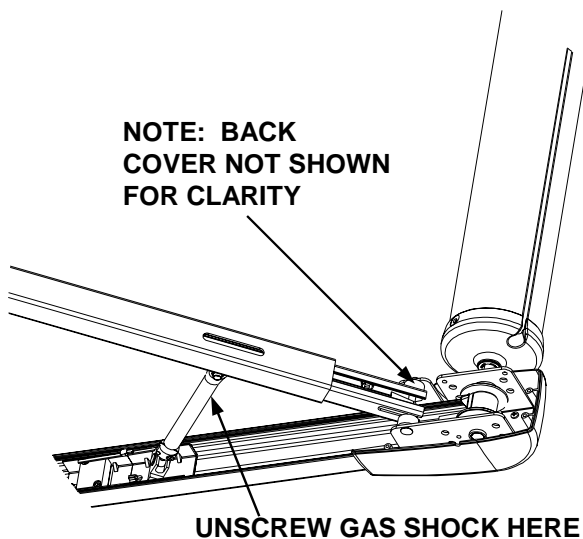

- C. Remove top bracket lag bolts that are attaching the top bracket to the vehicle. Take care not to scratch the vehicle with the top brackets when removing.

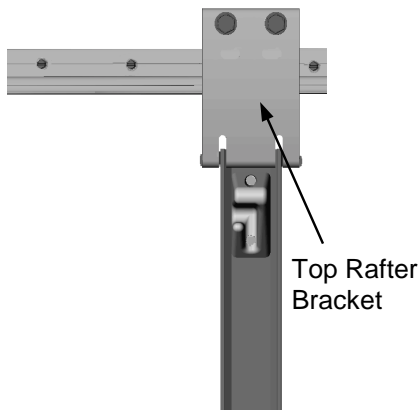

- D. Fold top portion of rafter toward lower portion.
- E. Slide rafter outward until the slot of the rafter bottoms out on the retaining pin. Depress spring and slide spring under pin and remove rafter and set aside.

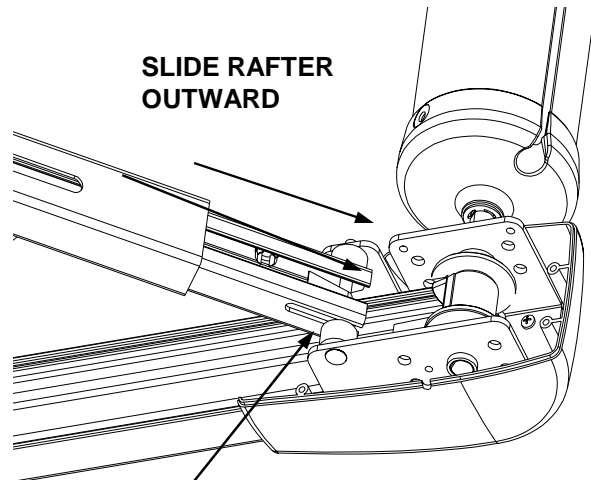

**SLIDE RAFTER OUTWARD UNTIL THE SLOT OF THE RAFTER BOTTOMS OUT ON THE RETAINING PIN. DEPRESS SPRING AND REMOVE RAFTER**

- F. Depress the spring on the top of the new rafter and slide it upward between the two bushings until the slot in the end of the rafter bottoms out on the retaining pin. The spring will then hook over pin. (Reversing the above steps)

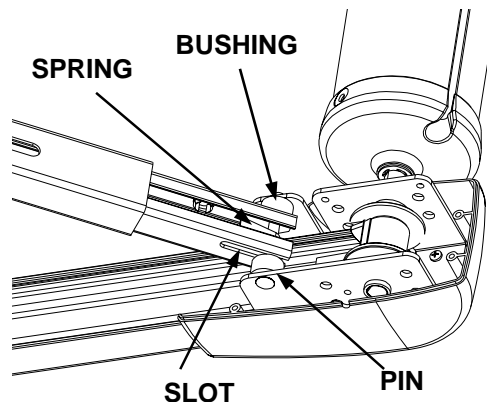

- G. Using silicon caulk and the previously removed lag screws, re-attach the top bracket.
- H. Using caution not to unthread the lower portion of the Gas shock, thread the upper portion of the shock into The rafter swivel bracket. Pliers may be needed to hold the lower portion of the shock.
- I. Roll awning completely out. Locate the Rafter Adjustment measurement sticker (as shown on front page) on the front rafter. (if your rafter is adjustable and has a sticker.) Roll the awning half way in and adjust the back rafter to match the front rafter measurement.

If the front rafter is not the adjustable style and has no sticker, with the awning rolled completely out, measure the front rafter from top pivot point to bottom pivot point and then roll the awning half way in and adjust the back rafter to match the measurements taken on the front rafter.

## SECTION ONE

## INSTALLATION INSTRUCTIONS (cont.)

### Step Two: Locating Existing Electronic Components

A. Locate the Power Control Module and the Power Control Switch that were previously installed in the vehicle.

**Power Control Module looks like this and is probably located in an overhead cabinet or possibly behind or under the dash. There will be wire running from this to a 12 volt power source, to the switch and to the Receptacle installed on the sidewall just to the left of the front arm assembly of the awning.**



**Power Control Switch looks like this and is probably located in an overhead cabinet, passenger side armrest, or in the dash.**



B. Once the components are located, unplug the 3 and 2 pronged connectors from the Power Control Module. Remove the screws attaching the control module (if applicable) and set that control module aside. You will use the **Red, Hot** 12-volt wire and the **Black, Ground** wire from the existing 3 pronged plug. The **Blue** wire will no longer be used. The 2 prong connector will be used to plug into the new control box.

C. Remove the screws attaching the switch panel to gain access to the wiring on the back of the panel. Disconnect the wiring from the back of the switch panel. These wires will no longer be used. Set the old switch panel aside. The hole that was cut for the old switch panel will now need to be enlarged to a 2-1/4" diameter hole. Follow the upcoming instructions for proper wiring of the new control panel and switch panel.

### Step Three: Install the Power Control Module and Power Control Switch

**Tip:** For optimum performance, always ensure electrical connections are clean, dry, and tight. When using solderless terminals or other methods of attaching or connecting wires, it is recommended to use heat shrink tubing to reduce corrosion contamination and the possibility of corroded connections or an open circuit.

**THE POWER CONTROL MODULE AND THE POWER CONTROL SWITCH COME STANDARD, INTEGRATED INTO ONE COMPONENT. THIS MAINLY APPLIES TO NEW INSTALLATIONS OF COMPLETE AWNING. IT IS INTENDED TO BE USED LIKE THIS IN CASES WHERE THE COMPLETE UNIT CAN BE SAFELY INSTALLED IN A SUITABLE LOCATION. THIS LOCATION SHOULD BE WHERE IT DOES NOT INTERFERE WITH ANYTHING BUT ALSO WHERE ACCESS CAN BE GAINED TO THE SWITCH CONTROLS. IT IS RECOMMENDED THAT THIS LOCATION BE SUCH THAT THERE IS SUFFICIENT VIEW OF THE ONE-Touch AWNING DURING OPERATION.**

**IN DOING AN AUTO-RETRACT UPGRADE, SUCH AS THIS, IN MOST CASES YOU WILL WANT TO MOUNT THE SWITCH PANEL IN THE SAME LOCATION AS THE ORIGINAL SWITCH PANEL. WHEN DOING SO, THE POWER CONTROL SWITCH PANEL MAY BE REMOVED FROM THE CONTROL MODULE AND PLACED REMOTELY, IN THE LOCATION OF THE PREVIOUS SWITCH PANEL.**

**FOLLOW THE INSTRUCTION STARTING ON THE NEXT PAGE AS THEY RELATE TO YOUR APPLICATION.**

Power Control Module With Power Control Switch Attached

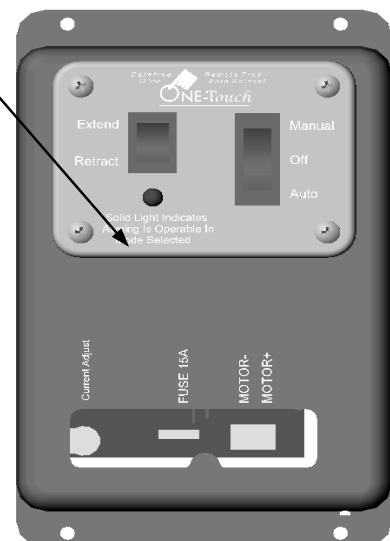

### Step Three: Install the Power Control Module and Power Control Switch (cont.)

#### **MOUNTING OF THE POWER CONTROL MODULE AND THE SWITCH PANEL IN EXISTING LOCATIONS.**

A. Review the wiring diagram on page 8. Determine a suitable location to mount the Power Control Module which allows convenient wiring for the ONE-Touch Awning.

**Whenever possible, mount the new Power Control Module in the same location as the one previously removed.** If not possible, then typical locations include: in an overhead cabinet near the entry door, or in a protected exterior compartment.

**NOTE: Power control Module must not be mounted in a area surrounded by a metal enclosure.**

**Warning:** Do not mount the Power Control Module and Switch near heat producing elements such as LP appliances or engine exhaust components.

**Caution:** If the location of the Power Control Module is now different than the one previously removed, minimum wire length and maximum wire size should be selected to assure adequate voltage to the ONE-Touch Awning motor.

B. Once the location of the Power Control Module has been determined, remove the screws attaching the face of the switch plate to the Control Module Box.

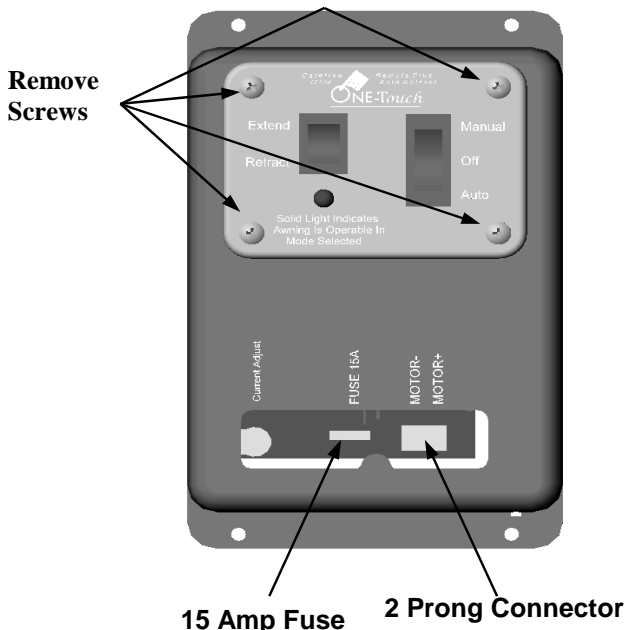

### Step Three: Install the Power Control Module and Power Control Switch (cont.)

C. Unplug the wire connection going from the switch plate to the control module components. (like a telephone plug)

D. Locate the extension cord with adapter in the hardware pack. Route the extension cord from the location where the previous switch was mounted to the Control Module Box. **The male end of the extension cord will plug into the Control Module while the Adapter (female) end will plug into the back of the Switch Panel.** Conceal the cord behind corner trim molding or inside cabinets. If surface wiring is the only option, obtain After-market concealment raceways to safely route cord.

E. Plug the male end of the extension cord connector into the Control Module where the switch panel was just removed.

F. Confirm that the hole size for the switch panel is now 2-1/4" in diameter. Plug the adapter (female) end of the extension cord into the plug coming out of the back of the Switch Panel.

G. Fasten the Control Module in place vertically using the screws provided.

**NOTE: The Control Module should be mounted vertically (not laying down) in order to obtain proper antenna operation.**

H. Plug the two prong connector that was previously unplugged from the original control module into the connector of the new control module located in the slot on the face of the control module.

H. Mount the switch panel using the previously removed screws.

I. Connect the unattached end of the red wire coming out of the Control Module to the previously identified **HOT** wire that was that was disconnected in step One B on the previous page.

J. Connect the unattached end of the black wire coming out of the Control Module to the previously identified **GROUND** wire that was disconnected in Step One B on the previous page.

## Step Four: Activating Transmitter

**A.** Roll awning half way out per the Operating Instructions. Move to the rear arm. Carefully remove the white tab located on the transmitter installed in the rear rafter. Removing this tab will allow the transmitter battery terminal to make contact. **Take care not to damage or pull out rubber cover when removing tab.**

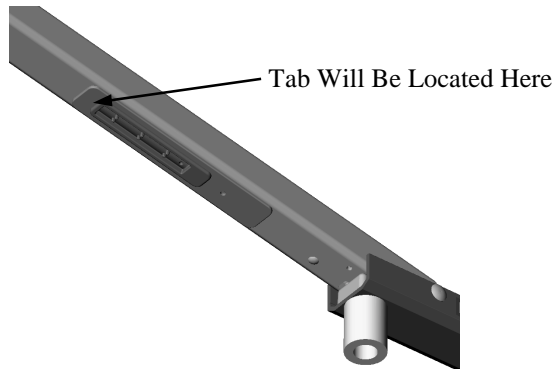

## Step Fourteen: Setting Transmitter Code

### SETTING THE AUTO-RETRACT TRANSMITTER

**A.** While being positioned close to the power control module with the power switch on the control module in the Manual mode, fully extend the awning until the rafter is completely locked out.

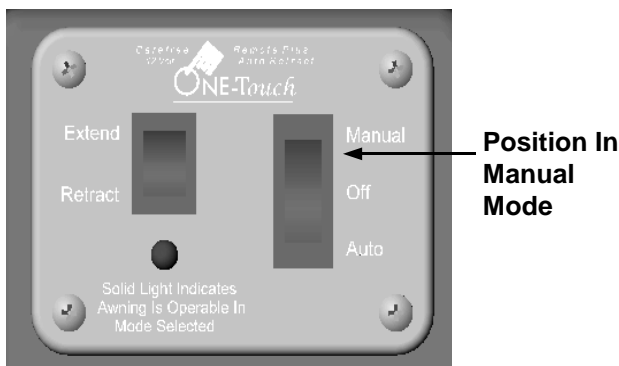

**B.** Verify that elbow switch is completely compressed between the nylon elbow stop on the upper portion of the rafter and the lower portion of the rafter.

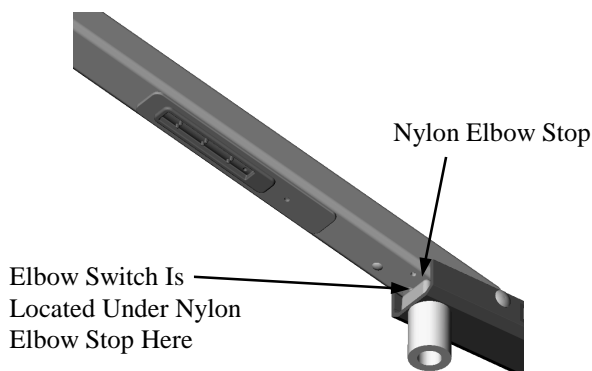

**C.** If elbow switch is not fully compressed when awning is in the complete rolled out position, re-adjust the carriages as shown on page 10 of the Regular One-Touch Owners Manual.

**D.** Right when the awning is fully extended and the rafters have fully locked out, listen (up to 15 seconds) to the control module for a long low tone then a short high tone.

**E.** Now, place the power switch on the control module in the Auto position. When you do this, watch the LED red light on the control panel. It might blink a couple of times and then it should turn to solid red. If the light turns to a solid red the Auto Retract system is activated.

**F.** If the LED light continues to blink, roll awning back in 3 revolutions and then roll completely out again and wait up to 15 seconds. The transmitter should then be set.

**G.** Verify the activation by pushing up on the roller assembly, buckling the rear rafter causing the micro switch to trip the auto retract. The awning should start retracting at that point.

**THE INSTALLATION IS NOT COMPLETE. PLEASE MAKE SURE THIS MANUAL IS GIVEN TO THE CUSTOMER TO ENSURE PROPER OPERATION!**

## SECTION TWO

## OPERATING INSTRUCTIONS

**THE ONE-Touch AWNING CAN BE USED IN EITHER A FULL MANUAL MODE OR IN THE AUTO RETRACT MODE. THE MANUAL MODE REQUIRES YOU TO DEPRESS THE SWITCH ON THE SWITCH PANEL OR USE THE REMOTE CONTROL TO EXTEND AND RETRACT AWNING. IF SET IN THE AUTO RETRACT MODE, THE AWNING WILL AUTOMATICALLY RETRACT WHEN THE WIND REACHES A VELOCITY THAT COULD DAMAGE THE AWNING IF LEFT OUT.**

**Warning:** If the awning is partially deployed the awning will not be resistant to wind; partial extension is recommended in calm conditions only. Additionally, Do not extend the awning in gusty wind conditions. **If the awning is to be left unattended or used in breezy wind conditions when in the Manual Mode, it is highly recommended that the Wind Braces provided to be positioned between both Rafter assemblies and Arm assemblies.**

**Note:** The RV must be positioned relatively level for the Carefree ONE-Touch awning to operate properly.

**Tip:** For optimum performance, be sure the battery systems are fully charged or the power converter energized.

### How the Power Control Module Works

To prevent damage to the ONE-Touch motor and circuitry, the Power Control Module monitors the current drawn by the motor. If the current draw exceeds the preset factory level, the power control module shuts off the power to the awning momentarily. This will occur if the power switch continues to be operated after the awning is fully retracted or extended. To reduce wear on the awning and it's power system do not continue to operate the power switch after full extension or retraction.

### Step One: To Use In Manual Mode

**A. TO EXTEND:** Place the awning in the Manual Mode by depressing the 3 position rocker switch on the Power Control Switch Panel that is marked "Manual". (figure 16) Operate the power switch in the "EXTEND" mode. Extend the awning until the roller assembly stops turning. At this point the fabric will be slightly slack. Jog the "RETRACT" switch slightly to tighten canopy.

**Note:** If the awning is only to be partially extended, simply release the momentary rocker switch when the awning is extended to the point desired.

**B. To Retract:** Position Power Control Switch in the Manual Mode and operate the power switch in the "RETRACT" position until the awning is fully retracted. Place switch panel in the OFF position.

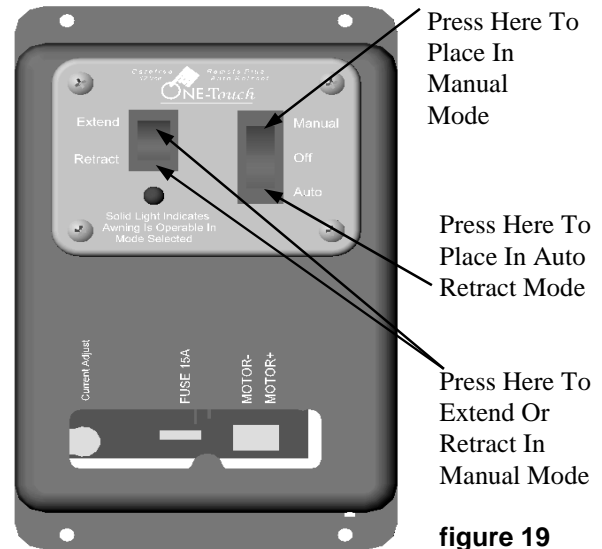

### Step Two: To Use In Auto Retract Mode

**A. TO EXTEND:** Depress the 3 position rocker switch on the Power Control Switch Panel that is marked Manual. Operate the power switch in the "EXTEND" mode until the awning is completely extended. Jog the "RETRACT" switch slightly to tighten canopy.

**B.** Wait approximately 3 seconds and then depress the "AUTO" switch. Within 10 seconds of depressing the "AUTO" switch, the red LED light should be a steady light (not flashing). If the light is steady then the Auto Retract is activated. If the light is flashing then depress the "MANUAL" switch and retract awning 3 revolutions. Extend again and wait 3 seconds and depress the "AUTO" switch again.

The Auto Retract is now activated and the awning will retract when the wind reaches a velocity that could damage the awning if left out.

**WARNING: DO NOT USE THE WIND BRACES WITH THE AWNING IN THE AUTO RETRACT MODE!**

**C. TO RETRACT:** Position Power Control Switch in the Manual Mode and operate the power switch in the "RETRACT" position until the awning is fully retracted. Place switch panel in the OFF position.

### Step Three: Using The Remote Control

**THE REMOTE CONTROL FOB CONTAINS THREE BUTTONS. TOP BUTTON IS USED FOR "EXTEND", THE BOTTOM BUTTON IS USED FOR "RETRACT" AND THE CENTER BUTTON IS AN EMERGENCY "STOP" BUTTON.**

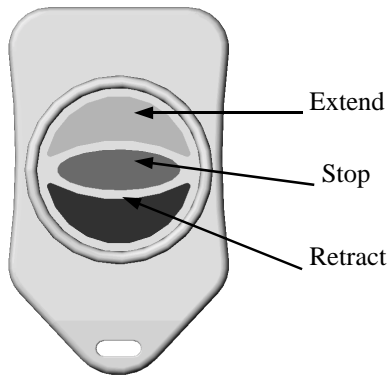

**A. TO EXTEND:** Place the awning in the Manual Mode by depressing the 3 position rocker switch on the Power Control Switch Panel that is marked "Manual". (figure 16)

Press the top button or "**EXTEND**" button on the Remote Control. Hold down the button until the awning reaches full extension. Jog the bottom "**RETRACT**" button slightly to tighten canopy.

**B. TO RETRACT:** Press the bottom "**RETRACT**" button. Hold button down for 2 seconds until the awning starts to retract. Once the awning starts retracting, the remote will automatically "latch" in place. After 2 seconds, once the awning starts to retract, release the button and the awning **will** continue to retract. **DO NOT CONTINUE TO HOLD DOWN ON THE RETRACT BUTTON ONCE THE AWNING BEGINS TO RETRACT! DOING SO WILL NOT ALLOW THE AWNING TO RETRACT PROPERLY!** If stopping the awning from retracting is desired at any point, press the "**RETRACT**" button again, or press the center "**STOP**" button. Once fully retracted, place switch panel in the **OFF** position.

#### STOP BUTTON

**The center STOP BUTTON can be used to stop the awning at any time during retraction. The STOP BUTTON will stop the awning from retracting in either the MANUAL OR THE AUTO RETRACT MODE.**

### Emergency Retraction of Awning

If an alternative minimum 12 volt power source is available:

If power from the RV is unavailable for operation, the Carefree ONE-Touch awning can be safely retracted by **disconnecting the power plug (located on the outside of wall of RV) and applying a positive and negative 12-volts to the two terminals located on the bottom side of the motor housing.**

Using the jumper cables provided attach a jumper lead to each of the terminals. Connect other ends of jumper Cables to a minimum 12V source. If the awning does not retract reverse the leads.

**Caution: Be careful when retracting the awning in this manner as the awning may move abruptly; it will be necessary to maintain contact with each of the two screw terminals throughout the retraction process.**

#### If no alternative 12 volt power source is available:

If power from the RV is unavailable for operation and no alternative 12 Volt power source is available,

The Carefree ONE-Touch awning can be safely retracted by disconnecting the power plug (located on the outside of wall of RV) and using a reversible electric drill fitted with the straight 9/64" hex key provided to turn the motor or using the L shaped hex key and turning it by hand.

The portion of the motor that can be turned is accessible though an opening at the base of the motor housing.

**Caution: Operate the drill in reverse at a low power setting to retract the awning. It will be necessary to turn the motor with the drill throughout the retraction**

#### IMPORTANT INFORMATION ABOUT TRANSMITTER BATTERY!

**THE TRANSMITTER CASE CONTAINS A SMALL A 23 BATTERY FOR OPERATION. IF THE BATTERY BEGINS TO GET LOW, THERE WILL A CHIRPING SOUND (SIMILAR TO A SMOKE ALARM) THAT WILL BEGIN TO COME FROM THE CONTROL MODULE. WHEN THE CHIRPING SOUND APPEARS, THE BATTERY SHOULD BE REPLACED.**

**TO REPLACE THE BATTERY, SIMPLY REMOVE THE RUBBER COVER FROM THE TRANSMITTER CASE, REMOVE AND REPLACE THE BATTERY AND CAREFULLY REPLACE THE RUBBER COVER SO THAT IT HAS A PROPER SEAL.**

