



Owner's Manual

Section OneInstallation Instructions

Section TwoOperational Instructions

Section Three.....Troubleshooting and Adjustments

Section Four.....Maintenance

Section Five.....Warranty Information

Review this diagram before preceding

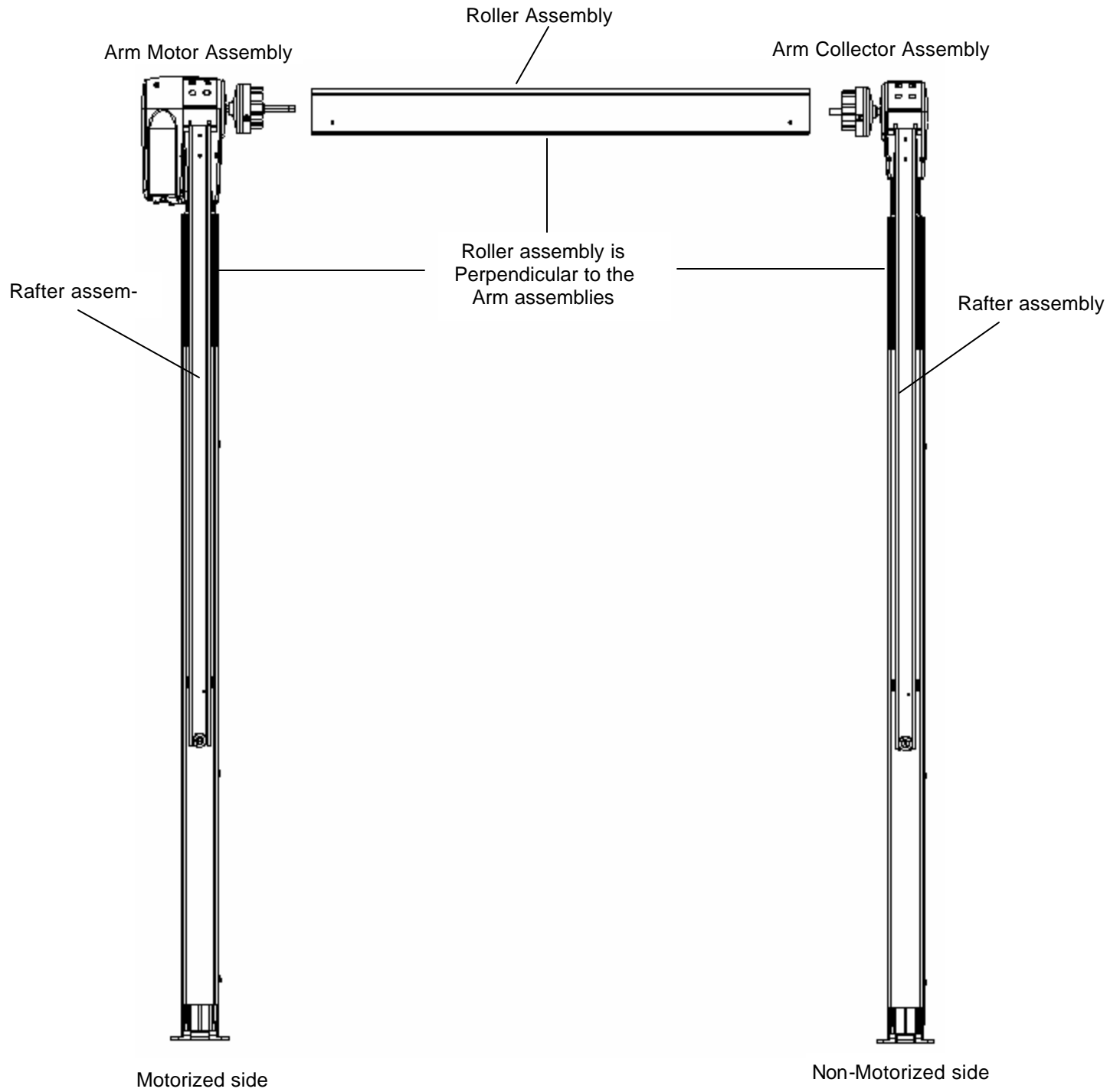

Section One

Installation Instructions

Read the entire contents of this manual prior to performing any portion of the installation. Use these instructions for the installation of the Carefree ONE-Touch awning only. Follow all cautions, warnings and notes to prevent injury or damage to the awning or the recreation vehicle.

Safety Information

Caution: Indicates a hazard that may cause minor or moderate personal injury or physical property damage if the caution is ignored.

Warning: Indicates a hazard that may cause serious personal injury or major physical property damage if the warning is ignored.

Note: Indicates information that may be helpful within the context of that particular step.

Tip: Provides helpful suggestions during the installation procedures or during actual use of the ONE-Touch awning.

A. Verify the awning rail is installed properly. If no rail is installed, mount one using rivets or screws. Seal the back of the rail with butyl caulk or putty tape.

Caution: The awning rail must be secured to solid framework.

B. Be sure the awning rail is straight. Use a screwdriver to spread open the awning rail on the side the awning will be installed into (**figure 1**). Use a file to smooth the edges of the opening to avoid damaging the fabric.

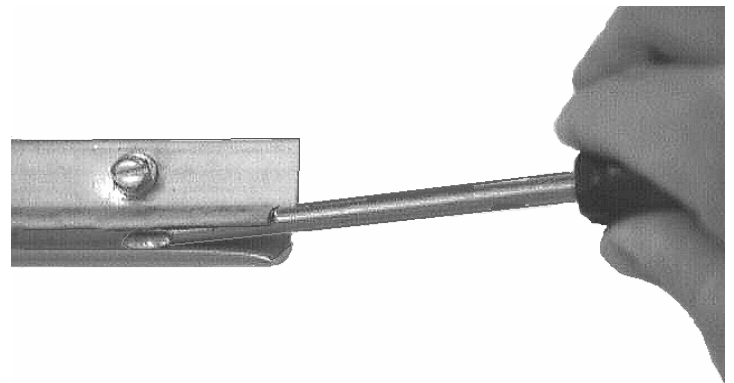

figure 1

Step One: Installation Recommendations

ONE INSTALLER (Two temporary helpers are beneficial)

TOOLS

- Tape Measure
- Step Ladder
- 15/16" Hole Saw
- 7/16" Socket/Nut Driver
- Ratchet or Speed Handle
- Flat or Round File
- Wire Crimper
- Diagonal Cutters
- 9/64" Hex Wrench
- Drill Motor
- 1/8" Drill Bit
- 3/16" Drill Bit
- #2 Phillips Screwdriver
- Caulking Gun
- Marking Pen
- Wire Stripper
- Square-drive Screwdriver #2

SUPPLIES

- Silicone Sealant
- Putty Tape (or equivalent)
- 14-gauge Primary Wire
- Silicone Spray Lubricant
- Heat Shrink Tubing
- Assorted Solderless Terminals

Step Two: Installation Preparation

Caution: The ONE-Touch awning must be mounted into the structural framework of the RV. Fiberglass or sheet metal siding alone is not strong enough to support the weight of the awning. Some trim moldings are aligned with actual floor members, but check to be sure. Mounting screws for the top and bottom brackets must attach solidly to the RV framework.

Step Three: Install Bottom Brackets

A. Determine the optimum positioning of the awning arms on the RV. Be sure the arms will not interfere with appliance exhaust vents, mirrors, storage compartments, etc. Consider the correct positioning while noting the wiring outlet must be installed through the side of the RV at a point 3" - 5" below the awning rail and 1" - 4" to the left of the front arm assembly. (figure 9)

Caution: Be sure side wall-mounted fixtures, such as the porch lamp, will not interfere with the wiring harness for the ONE Touch awning.

Note: (1) The size of a roller assembly indicates the exact footage between the centers of each bottom bracket and arm assembly once installed. For example, a 16-foot roller assembly requires the centers of the bottom brackets to be 16 feet apart when installed on the RV.

(2) The distance between the centers of the bottom brackets must be within 1/2" of the distance between the eventual centers of the top brackets.

(3) If exchanging existing Carefree hardware with One-Touch hardware, secure the roller assembly to the RV and remove the arms, springs, and top brackets.

B. Mount the front and rear bottom brackets into the floor line structure using the two, #14 x 2-1/2" lag screws.

Tip: For best results, pre-drill the lag screw holes (with a 3/16" drill bit) through any trim or molding and slightly into the floor structure. Inject silicone sealant into the holes before installing the lag screws.

Step Four: Attaching the Arms to the Roller Assembly (Timing The Awning)

A. Carefully remove the roller assembly and ONE-Touch hardware from their packaging. Do not remove the plastic wrap on the arm assemblies or the flagged cotter pin from the non-motorized arm assembly at this time.

B. When the awning arms are attached to the roller assembly they should closely match figure 2 showing the awning assembly viewed from the motorized and non-motorized sides. Start by aligning the three V-shaped openings in the drive wheel with the three slots on the inside of the roll bar and inserting the drive wheel into the open end of the roller assembly.

Note: The polyrod on roller assemblies or driprail on roller assemblies with Alumaguard must remain on the back side of the awning assembly for the ONE-Touch awning to operate properly.

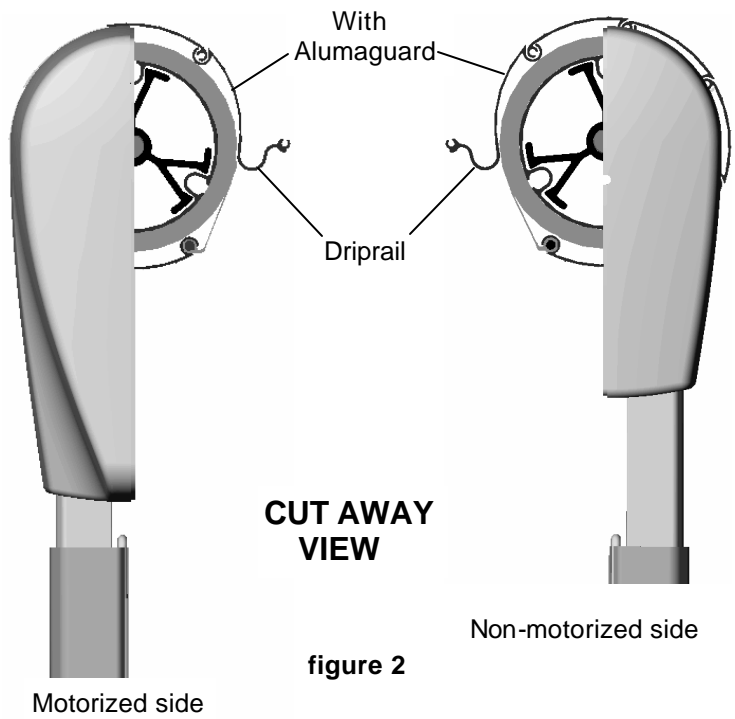
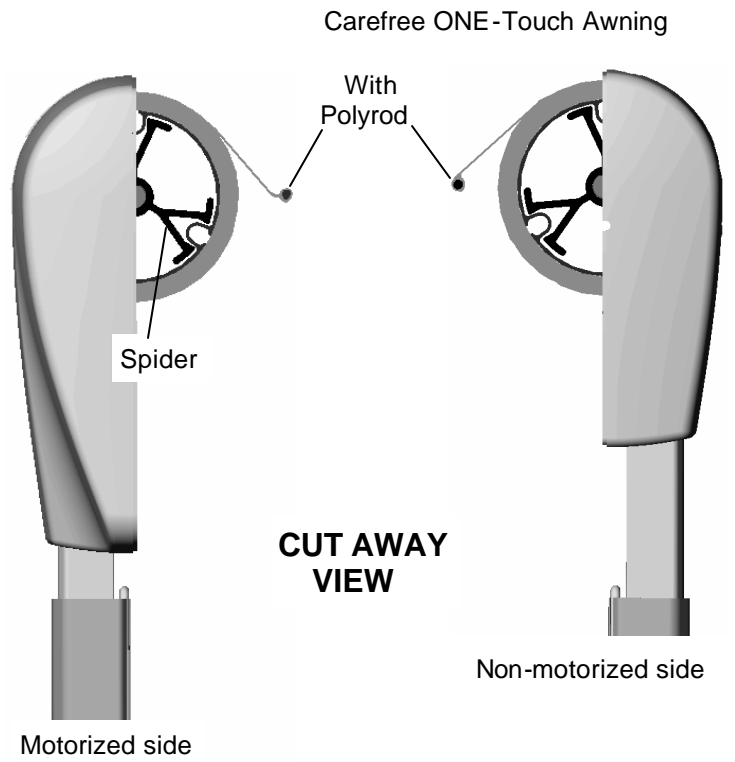

C. Rotate the end cap (it can be turned independent of the shaft) until its open slot aligns with the empty slot in the roller assembly; the other two slots in the roller assembly will have polyrod in them. Finish pushing the drive wheel all the way into the roller assembly; the end cap should seat squarely against the end of the roller assembly when inserted all the way in.

Warning: Exercise caution when handling the attached arm and roller assembly. The arm assembly must remain perpendicular to the roller assembly (see page 2). Failure to handle the arm assembly in this manner will bend the drive shaft.

D. Secure the end cap to the roller assembly using two, #10 square-drive screws (**figure 3**).

E. Repeat steps 4A through 4D for the non-motorized arm assembly.

F. Remove the flagged cotter pin from the non-motorized arm assembly after the arm is attached.

Warning: Exercise caution when handling the attached arms and roller assembly. The arm assemblies must remain perpendicular to the roller assembly (see page 2). Failure to handle the arm assemblies in this way will bend the drive shafts.

G. Unwrap one full turn of fabric or fabric & Alumaguard from the roller assembly to allow for clearance around mirrors, lamps, etc., when sliding the roller assembly polyrod or Alumaguard drip rail into the awning rail mounted on the RV.

Note: If exchanging existing Carefree hardware with One-Touch hardware, secure roller assembly to RV and remove existing arms, springs, and top brackets. Refer to **Step 5** for adjusting Arms to proper length. Install each Arm into its bottom bracket and unwrap the roller assembly one full turn. Precede with steps 4-A through 4-F for fitting the Arms To the Roll Bar.

Carefree ONE -Touch Awning

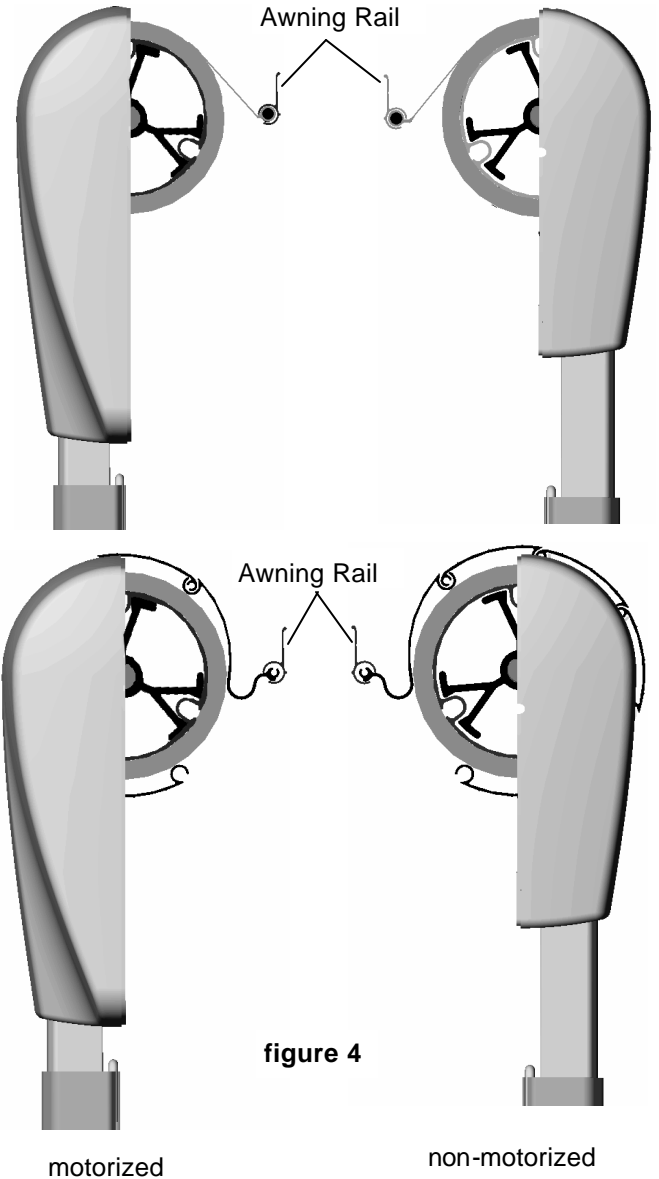

figure 4

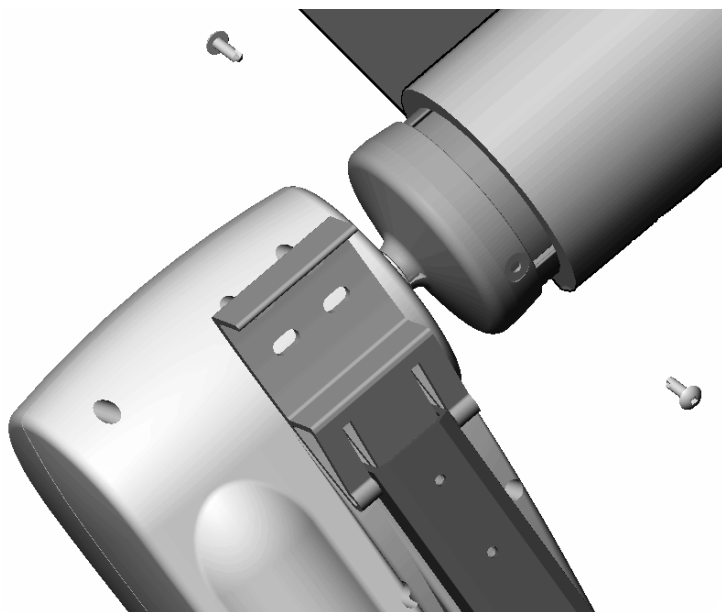

figure 3

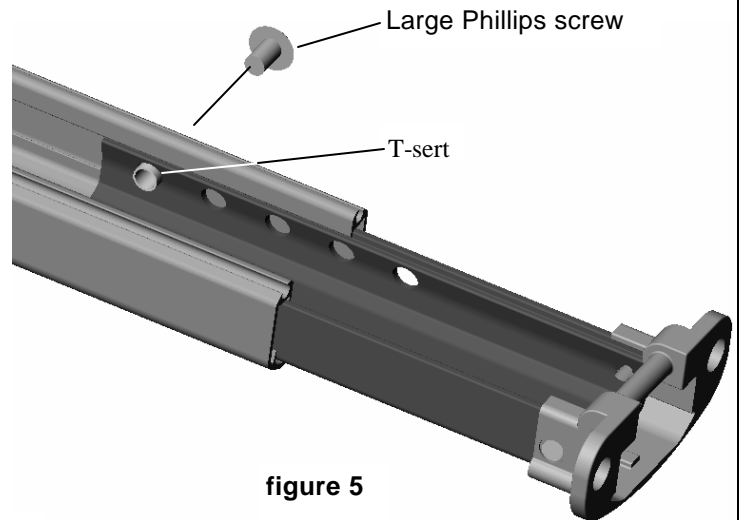

figure 5

Step Five: Installing the Awning Assembly on the RV.

A. When the awning assembly is installed on the RV it should closely match (figure 4) showing the awning assembly viewed from the motorized and non-motorized sides. Start by removing the large Phillips Screw assembly on the side of the motorized arm assembly and slide the adjustable leg out of the arm assembly (figure 5).

B. Measure the distance between the bottom brackets and the awning rail (figure 6).

C. Adjust the motorized arm assembly to the proper length using Table 1. Match the measurement taken in step 5B to the appropriate numbered hole needed to reattach the adjustable leg.

Table 1

Measurement in figure 6	Use hole number below to reinstall adjustable leg	Length of adjustable leg
76"	7	14.5"
76"	2	
77"	3	
78"	4	
79"	5	
80"	6	
81"	7	
82"	8	
83"	9	
84"	10	
85"	11	

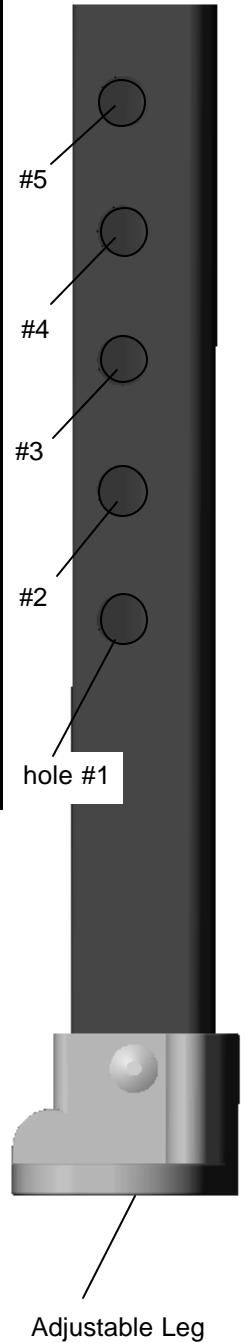
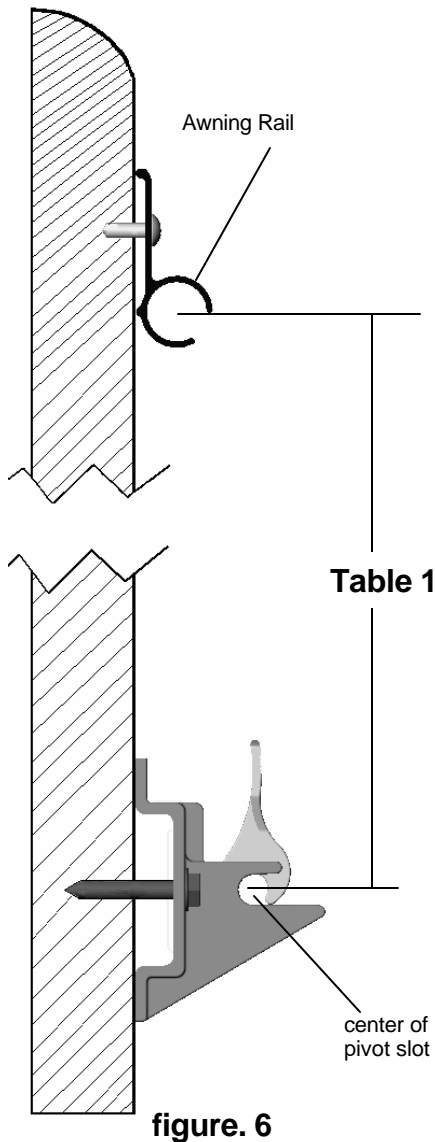

D. Repeat steps 5A through 5C for adjusting the length of the non-motorized arm assembly.

Note: Both the motorized and non-motorized arm assemblies should use the same numbered hole for reattaching the adjustable legs.

E. Now that the ONE-Touch awning is assembled and adjusted for the RV, use two helpers to lift the awning into a vertical position so the roller assembly is at the top.

Warning: Exercise caution when lifting and handling the awning assembly. Both arm assemblies must remain perpendicular to the roller assembly and parallel to each other (see page 2). Failure to handle the awning arms in this way will bend the drive shafts.

Tip: Silicone spray lubricant applied to the awning rail will allow for easier installation during step 5F.

F. Carefully slide the awning polyrod or the Alumaguard drip rail into the awning rail as the helpers alternately guide the front and rear arms (figure 7).

G. Once the awning arms are aligned with the previously installed bottom brackets, snap the bottom portion of each adjustable leg into its bottom bracket and allow the awning to lean away from the side of the RV.

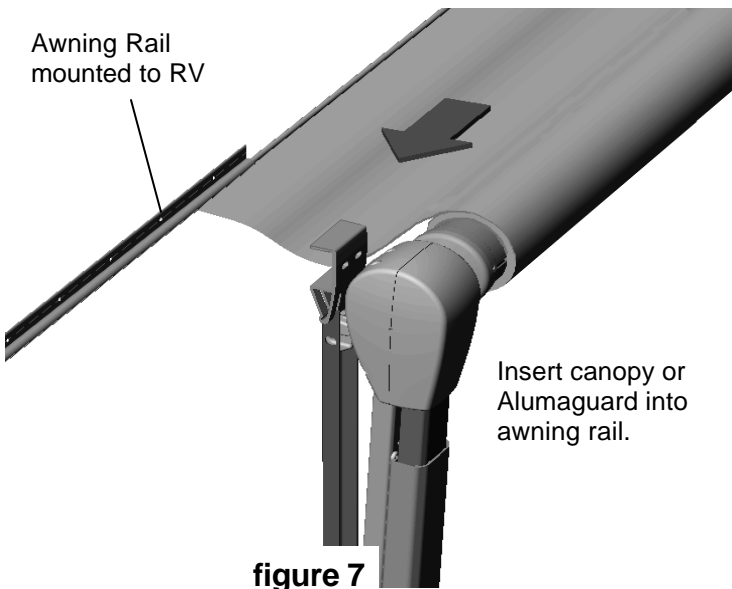

Step Six: Install the Top Brackets

A. Remove the plastic wrap from the motorized arm assembly and position of upper bracket at the awning rail. The top bracket should straddle the awning rail and be positioned fully up against the bottom of the rail (figure 8). The brackets should be straight up and down (not angled) for proper operation. (See below for your style of bracket)

Note: The distance between the centers of the top brackets must be within 1/2" of the distance between the centers of bottom brackets. Also the awning arms must be perpendicular to the awning roller assembly (see page 2).

B. Secure the bracket into the roof line using two, #14 x 3" lag screws.

Tip: For best results, pre-drill the lag screw holes with a 3/16" bit through the awning rail and slightly into the structural support member. Inject silicone sealant into the holes before installing the lag screws.

C. Repeat Steps 6A & 6B for the non-motorized arm.

SINGLE PIECE BRACKET

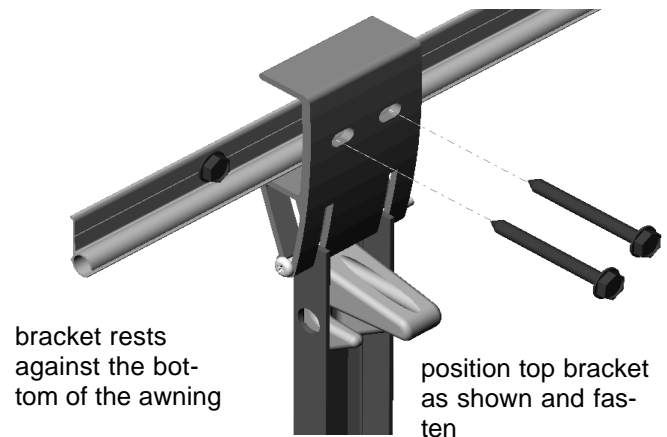
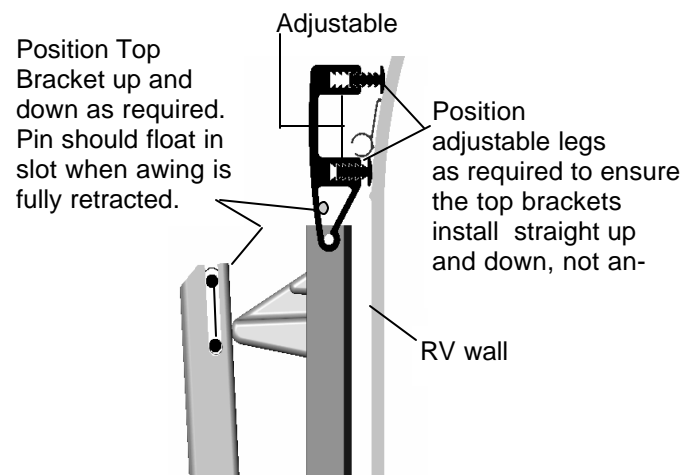

figure. 8

FOR MULTI-PIECE BRACKETS



REVIEW KEY ELECTRICAL COMPONENTS BEFORE PRECEDING



Power Control Module



Power Control Switch



Outlet

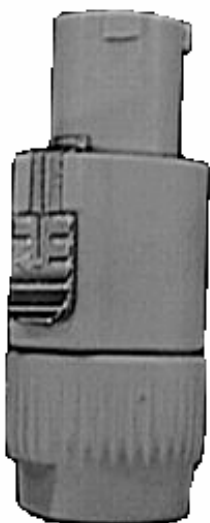

Plug



Wire Joint

Step Seven: Install the Power Control Module and Power Control Switch

Tip: For optimum performance, always ensure electrical connections are clean, dry, and tight. When using solderless terminals or other methods of attaching or connecting wires, it is recommended to use heat shrink tubing to reduce corrosion contamination and the possibility of corroded connections or an open circuit.

A. Review the wiring diagram in page 8. Determine a suitable location to mount the power control module and power control switch that will allow convenient wiring and sufficient view of the ONE-Touch Awning during operation while depressing the power switch. Typical locations include: just inside the entry door, in an overhead cabinet near the entry door, or in a protected exterior compartment. The switch assembly requires a rough cut-out opening that measures, 1" H x 2-1/4" W.

Note: A maximum of 18" of wire is available to connect the power control module to the power control switch. Consider the placement of the power control switch while evaluating power control module placement.

Caution: Minimum wire length and maximum wire size should be selected to assure adequate voltage to the ONE-Touch Awning motor.

Warning (1) The power switch is factory installed on a mounting plate beside a removable key switch; do not install the mounting plate in a location that will allow the key to be bumped into. Bumping into the key may cause minor injury or damage to the key.

Warning (2) Do not mount the control box or relay near heat producing elements such as LP appliances or engine exhaust components.

B. Once the location of the Power Control Module is determined fasten the control module in place using the screws provided.

C. After the location of the Power Control Switch is determined, cut out an opening in the mounting surface that measures, 1" H x 2-1/4" W. Run the wires connected to the Power Control Switch through the opening. Do not fasten the Power Control Switch in place at this time.

E. Plug the three pronged connector at the end of the wires running from the power switch into the three pronged outlet in the power control module.

F. Run a 14-gauge minimum (10 or 12 gauge preferred) wire from the positive terminal on the RV, power distribution panel (auxiliary battery circuit) to the positive wire (red)

power control module. Use two of the wire joints provided to connect one lead of the 15 amp fuse holder to the wire from the distribution panel and the other fuse lead to the positive wire (red) running from the three pronged connector.

G. Connect the unattached end of the black wire running from the wire joint shared with two other black wires to a suitable grounding locating on the RV. Use extra wires and a wire joint if necessary.

Note: A suitable ground would be the chassis of the RV or any other conductive structure attached to the chassis.

Step Eight: Mount the Outlet

A. Mark and drill a 15/16" hole in the exterior side wall, 3" - 5" below the slot in the awning rail and 1" - 4" to the left of the front arm of the awning (**figure 9**).

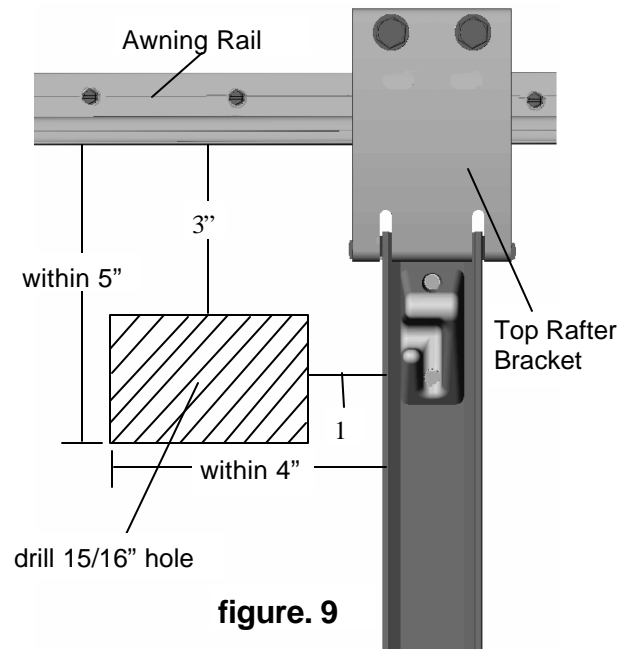

Tip: Use a sharp, 15/16" hole saw when drilling through laminate siding. A dull saw may result in an oversized hole or chipping and could allow potential moisture damage. For best results, try a few sample holes in similar scrap material.

Caution: Measure and mark carefully. Be aware of interior cabinet framing or other structures that may be located directly behind the wall. Shift the position as necessary while staying within the specified parameters. Be aware that structural obstructions may prevent proper hole drilling.

B. Route two, 14-gauge wires from the power control module up to and through the hole in the side wall of the RV. Use the wire joints provided to connect the two, 14-gauge wires to the two leads on the two pronged connector. Plug the two pronged connector into the two pronged outlet in the power control module.

Tip: Conceal the two, 14 gauge wires behind corner trim molding or inside cabinets. If surface wiring is the only option, obtain aftermarket concealment raceways to safely route the wires.

C. Connect the wires running from the two pronged connector to the terminals at the rear of the outlet using the spade connectors provided.

D. Apply silicon sealant or putty tape to the back of the flange and place the outlet in the hole with the tab slots at the 12 o'clock and 3 o'clock positions. Mount the outlet to the side of the RV using the screws provided. Carefully trim excess sealant from around the outlet. After installation the rubber cover may also be removed if desired

E. Plug the electrical harness from the front arm assembly into the outlet on the side of the RV.

Note: Align the tabs on the plug with the slots in the receptacle, (at the 12 o'clock and 3 o'clock positions), insert the plug fully and twist 1/8th of a turn clockwise until the metallic clip firmly latches in place. To disconnect, pull back on the metallic clip with your thumb while twisting the plug counter-clockwise 1/8th of a turn. Pull the plug straight out of the outlet.

Tip: Allow a downward loop to form in the harness out of the outlet to prevent rainwater from entering the plug.

Step Nine: Verify Operation

A. Extend awning completely out. If awning will not extend fully adjust both rafters "longer" by removing the screws (figure 10a) and increasing length of both ends of the rafters the same amount. If canopy extends but rafter does not lock out (figure 10) then "shorten" the rafter so the "elbow stop" completely locks out against the rafter "inner channel".

B. Extend the awning until the roller assembly stops turning. At this point the fabric will be slightly slack. The awning should deploy evenly; refer to the troubleshooting guide if it does not.

Note: (1) For Alumaguard models it may be necessary to assist the deployment of the awning away from the RV for steps 9A through 9F. Until the Alumaguard

Tractioner is installed in step 10b.

(2) If the motor runs in the reverse direction, it will be necessary to push the switch out of the Power Control Switch panel, flip it upside down and reinstall.

(3) The Power Control Switch panel may now be mounted in place.

C. Have available the 9/64 hex wrench provided. **Retract the awning until the roller assembly makes one complete turn.** While holding on to the Lower Carriage on the motorized arm assembly, cut and remove the cable tie attaching the Upper Carriage and Lower Carriage together. Move the Lower Carriage up until it touches the Upper Carriage (figure 9). Tighten the clamping screws on the Lower Carriage with the 9/64 hex wrench. Repeat this procedure on the non-motorized arm assembly.

D. Extend the awning until the rafters are at the maximum open position allowed by the Rafter Elbow Stop (figure 10). The Gas Shocks on both the arm assemblies should be compressed 1/4" - 3/4" at this time. Jog the power switch slightly to retract and tighten the canopy fabric.

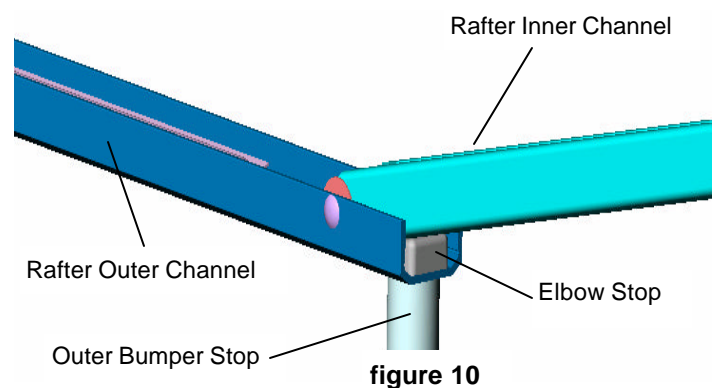
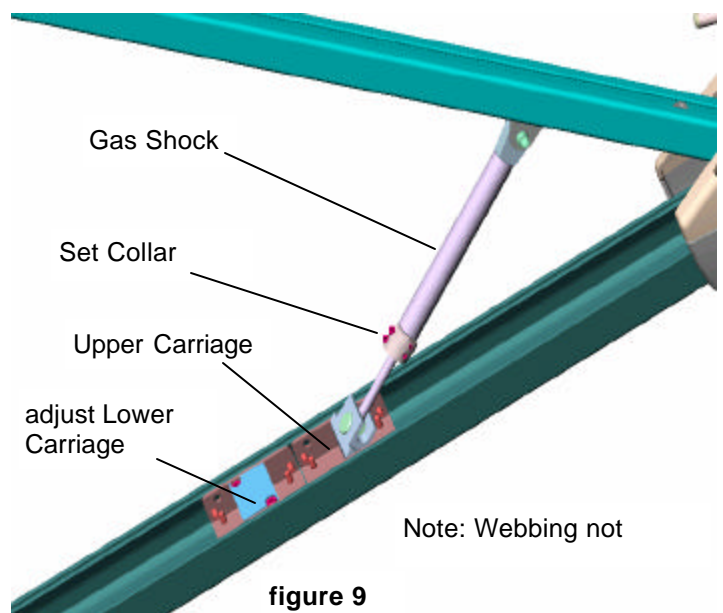

E. Move the Set Collar on the motorized arm assembly up until it touches the base of the gas shock and tighten the clamping screws with the 9/64 hex wrench. Repeat this procedure on the non-motorized arm assembly. (figure 9).

F. Cycle the awning in and out several times, (see the Operating Instructions in the next section), to be sure that it operates smoothly and the roller assembly is extending evenly away from the arm assemblies. Verify the rafters are unfolding properly and resting against the elbow stops when the awning is fully extended (figure 10). Refer to the troubleshooting guide if rafter operation does not appear correct.

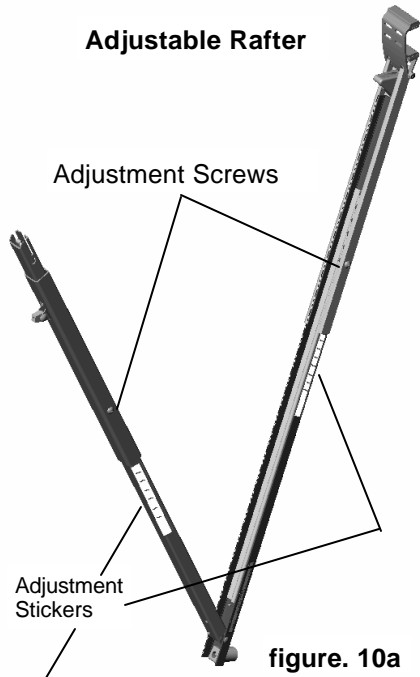

48"	47"	46"	45"	44"	43"
-----	-----	-----	-----	-----	-----

Adjust both connecting ends of the rafter to the same length. Remove this table after adjustment.

Step Ten: Securing the Canopy, Installing Tractioners and Safety Stops

A. Secure the canopy fabric or Alumaguard using one, #6 x 3/8" hex head screw at the front and back end of the awning (fig 11). For vinyl (non alumaguard) awnings place screws through awning rail, polyrod and canopy approximately 1" in from each end of the fabric. For alumaguard place screws just outside the edge of the alumaguard to prevent it from shifting.

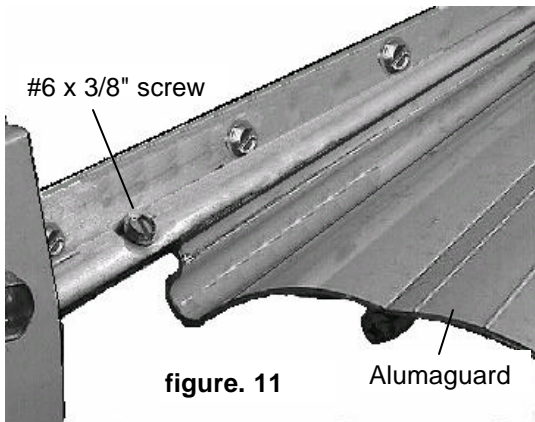

Alumaguard awnings only, require that you install Alumaguard Tractioner on each end of the roller assembly (fig 12).

- A. Grasp the Alumaguard Tractioner and O-Ring (shown in figure 12a) and disconnect one end of the O-Ring from the keeper on the Tractioner.
- B. Fully retract the awning and then extend it just enough to take tension off of the alumaguard wrap. (approximately 1/8 of a turn) Wrap the tractioner around the roller tube and re-connect the O-ring to the keeper.
- C. Position the tractioner as shown in figure 12b and 12c.
- D. Extend the awning and verify that the Alumaguard Tractioners are engaging the Alumaguard properly. When operating properly, the Alumaguard Tractioner will engage the end of the Alumaguard cover and move it up and over the roller assembly. If required, reposition tractioner to



Figure 12a

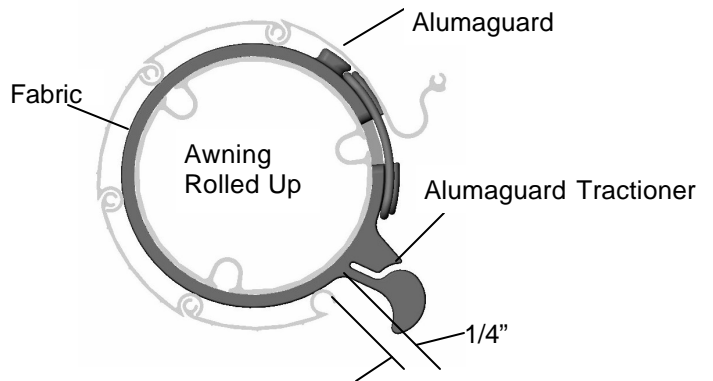
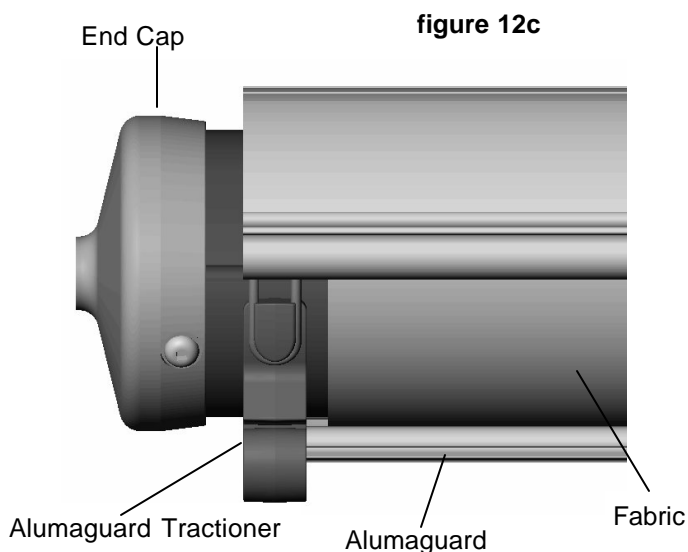
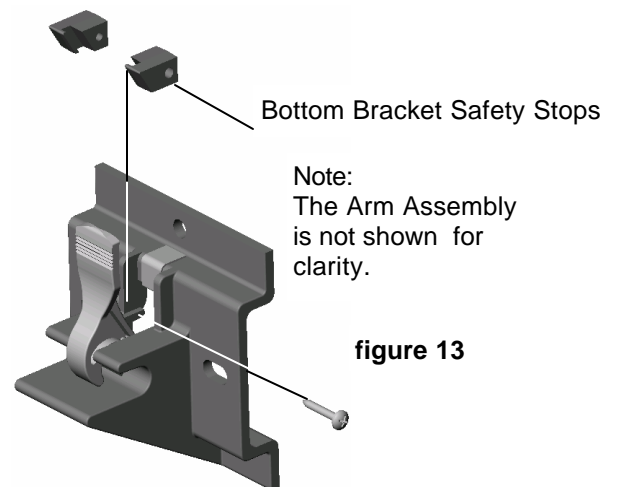

figure 12b

(See Figure 12c on next page)



A. Once installed the ONE-Touch arms must not be removed from the bottom brackets (NO CARPORT POSITION). To ensure the arms are not removed the quick install/release catch on the bottom brackets must be disabled by installing the Bottom Bracket Safety Stops (figure 13, right).



STEP ELEVEN: Installing Protective Pad
Retract awning until the rafter rubber bumper nearly makes contact with the sidewall. Stick the round clear protective pad on the sidewall of the vehicle at the point where the bumper will make contact once the awning is completely retracted.

Section Two

Operational Instructions

Warning: If the awning is partially deployed the awning will not be resistant to wind; partial extension is recommended in calm conditions only. Additionally, Do not extend the awning in gusty wind conditions. **If the awning is to be left unattended or used in breezy wind conditions it is highly recommended that the roller assembly Tie-Downs provided be used at each end of the roller assembly.**

Note: The RV must be positioned relatively level for the Carefree ONE-Touch awning to operate properly.

Tip: For optimum performance, be sure the battery systems are fully charged or the power converter energized.

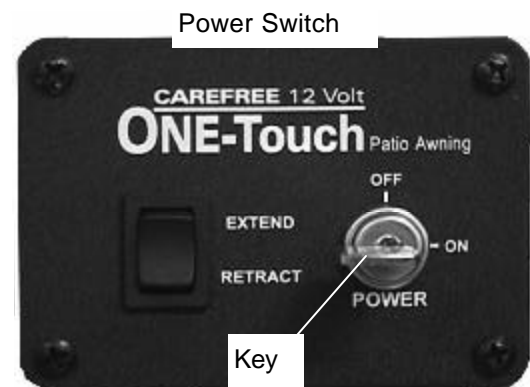

figure 14

How the Power Control Module Works

To prevent damage to the ONE-Touch motor and circuitry, the Power Control Module monitors the current drawn by the motor. If the current draw exceeds the preset factory level, the power control module shuts off the power to the awning momentarily. This will occur if the power switch continues to be operated after the awning is fully retracted or extended. To reduce wear on the awning and its power system do not continue to operate the power switch after full extension or retraction.

Step One: To Extend or Retract the Awning

A. To Extend: With the key in the “ON”, position, operate the power switch in the “EXTEND” mode. Extend the awning until the roller assembly stops turning. At this point the fabric will be slightly slack.

Jog the “RETRACT” switch slightly to tighten canopy.

Note: *If the awning is only to be partially extended, simply release the momentary rocker switch when the awning is extended to the point desired.*

B. To Retract: Operate the power switch in the “RETRACT” position until the awning is fully retracted.

Emergency Retraction of Awning

If an alternative 12 volt power source is available:

If power from the RV is unavailable for operation, the Carefree ONE-Touch awning can be safely retracted by disconnecting the power plug and applying a positive and negative 12-volts to the two terminals located on the bottom side of the motor housing.

Using the jumper cables provided attach a jumper lead to one of the terminals and touch the opposite lead to the other terminal. If the awning does not retract reverse the leads.

Caution: *Be careful when retracting the awning in this manner as the awning may move abruptly; it will be necessary to maintain contact with each of the two screw terminals throughout the retraction process.*

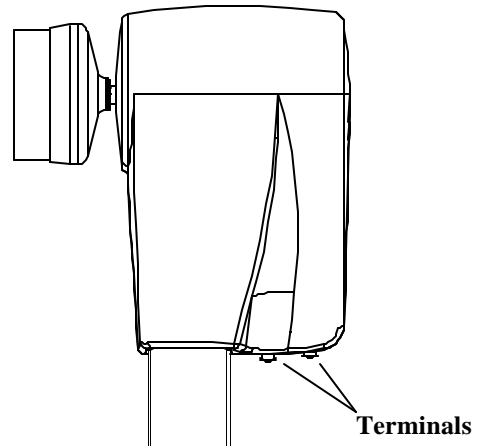

If no alternative 12 volt power source is available:

If power from the RV is unavailable for operation and no alternative 12 Volt power source is available, the Carefree ONE-Touch awning can be safely retracted by disconnecting the power plug and using a reversible electric drill fitted with the straight 9/64 hex key provided to turn the motor.

The portion of the motor that can be turned is accessible through an opening at the base of the motor housing.

Caution: *Operate the drill in reverse at a low power setting to retract the awning. It will be necessary to turn the motor with the drill throughout the retraction process.*

Wiring Diagram

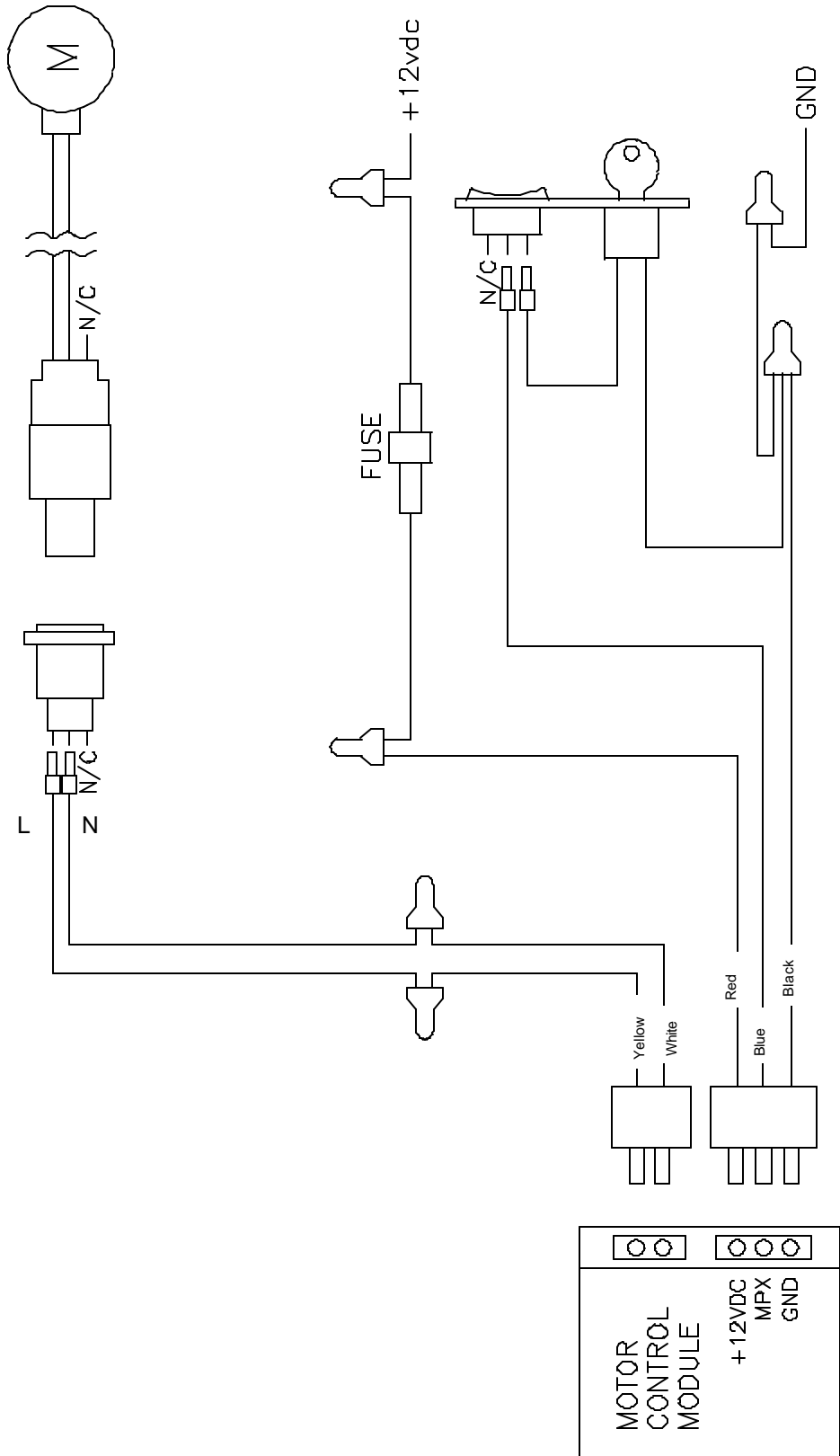

Section Three

Troubleshooting

PRODUCT: Carefree ONE-Touch Patio Awning

TITLE: ONE-Touch Awning Troubleshooting

DOCUMENT: TS10017 - 11/01/99

ONE-Touch AWNING TROUBLESHOOTING GUIDE

PLEASE REVIEW THE FOLLOWING TO OBTAIN INFORMATION REGARDING SYMPTOMS, POSSIBLE CAUSES AND SOLUTIONS TO ONE-Touch AWNING PROBLEMS.

SYMPTOM: The Rafter Arm will not extend to its complete extended position

? POSSIBLE CAUSE (1): The upper carriage is improperly adjusted causing the Gas Shock to engage prematurely.

◆ PROBABLE SOLUTION (1): Push the Extend Button on the Switch Panel and completely extend awning. Loosen the 9/64" Hex Head screws on the Lower Carriage as shown below. Move the Carriage down 8" to 10" and snug the screws up so the Carriage won't fall down into the arm. Push the Retract Button on the Power Switch panel and retract the awning one revolution. Move Lower Carriage up until it touches the bottom of the Top Carriage. Re-tighten Clamping Screws with 9/64" hex wrench. (see below)

? POSSIBLE CAUSE (2): Awning is out of time.

◆ PROBABLE SOLUTION (2) Retime awning following timing instructions shown in Step 4, Page 4 of this Owners Manual.

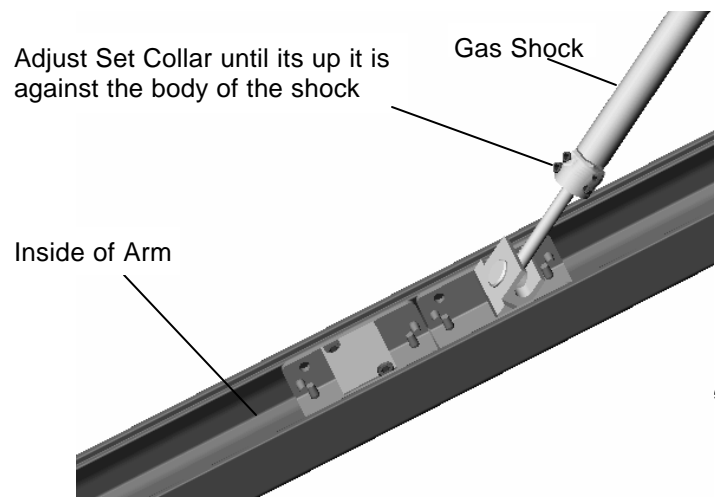
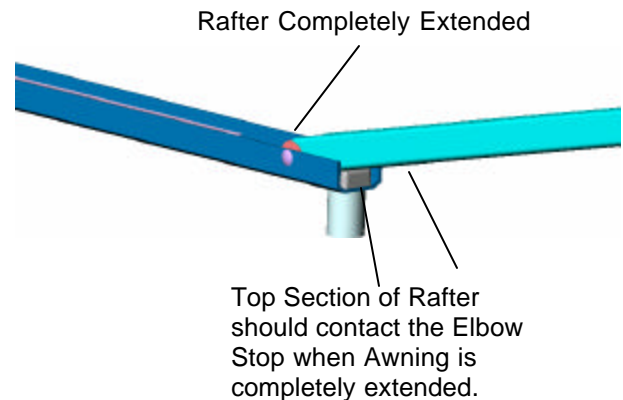

- To release Carriage, loosen screws here. be careful not to allow Carriage to slide down the Arm Channel.
- Adjust Lower Carriage until it touches the bottom of the Upper Carriage.
- Re-tighten screws.

SYMPTOM: *One side lifts higher or sooner than the other.*

? **POSSIBLE CAUSE (1):** The awning is out of time.

◆ **PROBABLE SOLUTION (1):** Retime awning following timing instructions shown in Step Four, Page Four of this Owners Manual.

? **POSSIBLE CAUSE (2):** Strap or straps are loose when the awning is in the retracted position.

PROBABLY SOLUTION (2): When the awning is completely retracted, check nylon strap inside of arm channel and see if it is loose. If loose, extend awning one revolution. Remove end cap screws and slide the drive wheel of the arm assembly out of the roller tube. Rotate drive wheel 1/3 of a turn until the strap is tight. Repeat on opposite end.

See Step Four, Page four of this Owners Manual for more detail.

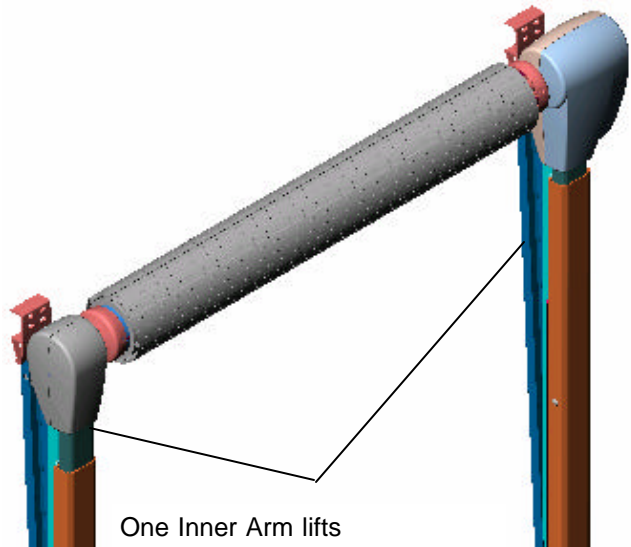

One Inner Arm lifts higher or sooner than the other

SYMPTOM: *Awning Does Not Extend*

? **POSSIBLE CAUSE (1):** Key switch in the "OFF" position

◆ **PROBABLE SOLUTION (1):** Position Key to "ON"

? **POSSIBLE CAUSE (2):** Low battery

◆ **PROBABLE SOLUTION (2):** Charge battery

? **POSSIBLE CAUSE (3):** Blown Fuse between the Power Control Module and the Power Supply.

◆ **PROBABLE SOLUTION (3):** Replace fuse

? **POSSIBLE CAUSE (4):** Battery disconnect circuits open

◆ **PROBABLE SOLUTION (4):** Close battery disconnect circuits

? **POSSIBLE CAUSE (5):** Incorrect wire connection, bad connections or bad grounds.

◆ **PROBABLE SOLUTION (5):** Refer to wiring diagram for correct connections. Check all wiring connections and grounds and make sure there is good contact. Repair as necessary.



? **POSSIBLE CAUSE (6):** No power to the motor.

◆ **PROBABLE SOLUTION (6):** Check for 12 volts at motor cover terminals, when switch is on. If there is no power there, check all wiring connections and grounds and make sure there is good contact. Repair as necessary.

? **POSSIBLE CAUSE (7):** Faulty component in the awning.

◆ **PROBABLE SOLUTION (7):** Disconnect the power plug at the RV wall. Using jumper cables provided connect a 12VDC source directly to the terminals at the motor cover. If this fails to operate the awning then there is a faulty component. At this point contact Carefree.

Disconnect
from wall here

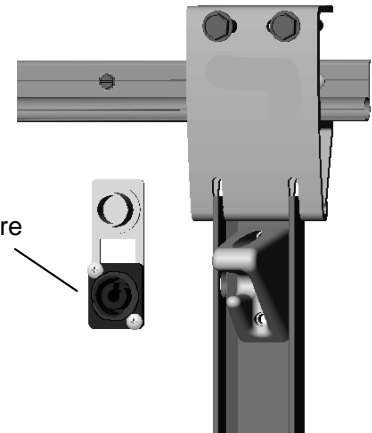

SYMPTOM: *The Roller Assembly spins but will not extend away from the RV.*

? **POSSIBLE CAUSE (1):** RV is not level.

◆ **PROBABLE SOLUTION (1):** Level the RV.

? **POSSIBLE CAUSE (2):** The center of the Roller Assembly is not at the same height as the center of the Awning Rail.

◆ **PROBABLE SOLUTION (2):** Move the adjustable leg at the base of the Arm Assembly so that the center of the Roller Assembly is closer to the same height as the center of the rail.

? **POSSIBLE CAUSE (3):** Roller is higher on one side than it is the other

◆ **PROBABLE SOLUTION (3):** Measure both Arm Assemblies and adjust stop bolts accordingly until the Roller Assembly is centered on the Awning Rail on both ends. (Both sides must be measured because it is possible that the relationship between the Awning Rail and the center of the Bottom Bracket will vary from one arm to the other).

? **POSSIBLE CAUSE (4):** If an Alumaguard Awning, the traction masters may not be installed or are not installed correctly.

◆ **PROBABLE SOLUTION (4):** Install or adjust traction master as shown on page 11 of this manual .

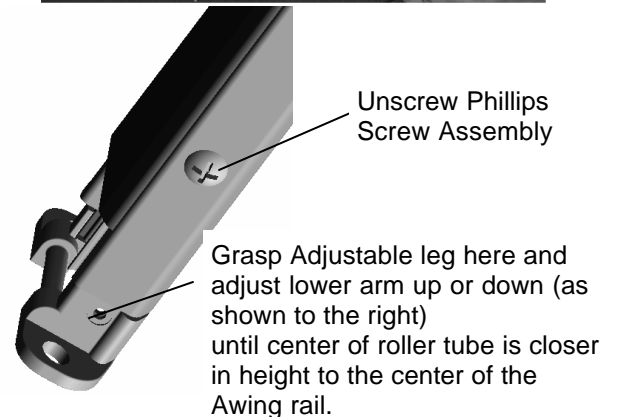
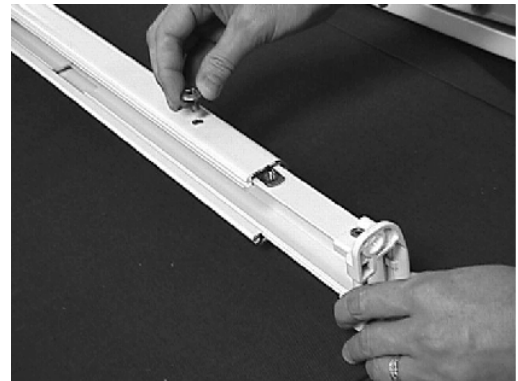

SYMPTOM: Awning does not retract or retracts slowly (greater than 30 seconds)

- ? **POSSIBLE CAUSE (1):** Motor Under powered
- ◆ **PROBABLE SOLUTION (1):** Check voltage from battery. If receiving low voltage charge battery.
- ? **POSSIBLE CAUSE (2):** Poor Connections or broken wires.
- ◆ **PROBABLE SOLUTION (2):** Clean and reinstall connections. Inspect wire for cuts, etc. and replace if necessary.
- ? **POSSIBLE CAUSE (3):** Inadequate wire size. Wire is not a heavy of enough gauge to carry the necessary load.
- ◆ **PROBABLE SOLUTION (3):** Minimize wire length and / or maximize wire size. A minimum of 14 gauge wire should be used. Use a larger gauge wire if running the wire a long span. Even though a minimum of 14 gauge wire is required, 10 or 12 gauge wire is preferred for the primary 12 Volt power wire.

SYMPTOM: Rafter arms rest on side of RV or backside of awning arm during retraction or extension.

- ? **POSSIBLE CAUSE (1):** The roller assembly is not centered to the Awning Rail.
- ◆ **PROBABLE SOLUTION (1):** Center roller assembly properly to Awning Rail.
- ? **POSSIBLE CAUSE (2):** Top bracket is mis-aligned
- ◆ **PROBABLE SOLUTION (2):** Reposition top bracket.

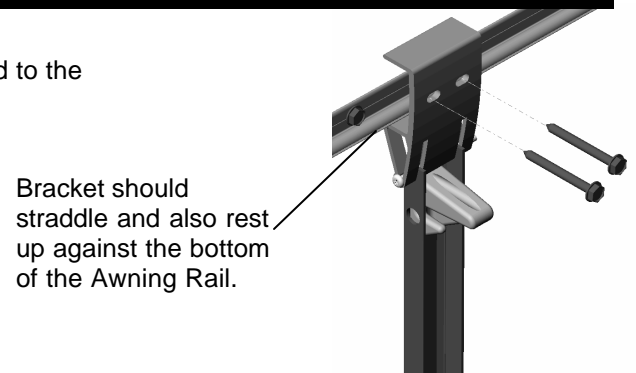
**SYMPTOM:** Fabric will not tension.

- ? **POSSIBLE CAUSE (1):** The Upper Carriage is not properly adjusted to allow Gas Shock to set the rafter.
- ◆ **PROBABLE SOLUTION (1):** Push the Extend Button on the Switch Panel and completely extend awning. Loosen the 9/64" Hex Head screws on the Lower Carriage as shown below. Move the carriage down 8" to 10" and snug the screws up so the carriage won't fall down into the arm. Push the Retract Button on the switch panel and retract the awning one revolution. Move lower carriage up until it touches the bottom of the top carriage. Re-tighten clamping screws with 9/64" hex wrench. (see right).

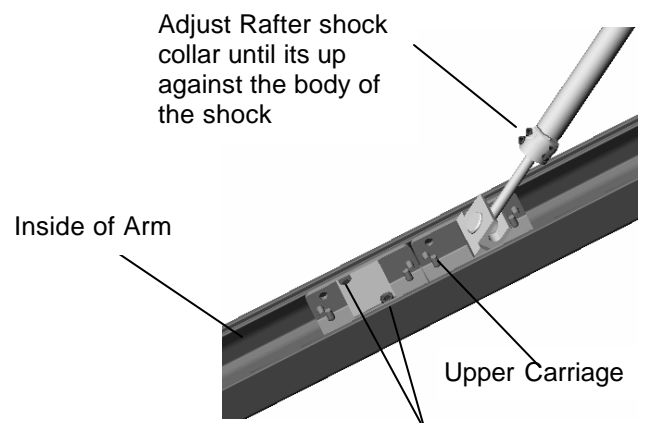

- ? To release Carriage, loosen screws here. Be careful not to allow Carriage to slide down the Arm Channel.
- ? Adjust Lower Carriage until it touches the bottom of the Upper Carriage.
- ? Re-tighten screws.

Section Four

- Periodically clean the fabric using a mild laundry detergent or an approved aftermarket awning or vinyl cleaner.
- When using cleaners, be sure to follow the manufacturers instructions carefully.
- Use only a soft brush for cleaning or scrubbing.
- Be sure to clean both sides of the fabric and to rinse thoroughly.
- Allow the fabric to dry completely before retracting the Carefree ONE-Touch Patio Awning. Do not use oil based cleaners or any caustic, granulated, or abrasive type cleaners on your Carefree ONE-Touch Patio Awning.

Maintenance

- Replace any parts that become damaged.
 - Once per camping season, clean the contacts on the electrical harness and receptacle on the side of the RV.
 - Periodically check all mounting hardware, screws, lags, etc., for tightness. Re-tighten when necessary. Keep the arm assemblies clean and free of debris by periodically flushing them with low pressure water (avoid introducing water into the motorized and non-motorized housings).
- ? Periodically apply dry silicone lubricant to both the arm assemblies and hardware beneath the motorized and non-motorized housings.
- ?When storing the RV turn the switch key to the "OFF" position and remove the key.

Section Five

Warranty Information

CAREFREE OF COLORADO AWNINGS "TWO & FOUR" YEAR LIMITED WARRANTY

1. DURATION: *Two years* on parts, freight and labor on canopies; and *four years* parts, freight and labor on spring assemblies (or motors), rollers and hardware. Please retain dated proof of purchase (receipt). Warranty duration is not extended by the length of time the product is not in use or the time which purchaser is deprived the use of the product. The duration of coverage on parts and repairs provided as per this warranty shall be determined by the date of the original product purchase (not by the date of repairs).

2. PRODUCTS: Warranty covers all Carefree of Colorado ONE-Touch, Spirit, Fiesta, Simplicity, patio awnings and all Carefree Window Awnings installed and operated as per Warrantor's instructions.

3. WHO GIVES THIS WARRANTY (WARRANTOR);
Carefree of Colorado
a Scott Fetzer Company

Telephone: 1-303-469-1152
Fax: 1-303-460-9106
2145 West 6th Avenue
Broomfield, CO 80020

No other person or company is authorized to change or amend the Warrantor's obligations set forth in this warranty.

4. WHO RECEIVES THIS WARRANTY (ORIGINAL PURCHASER): The first ("Original Purchaser"), other than for purposes of resale, of the Carefree of Colorado product that is properly installed and operated within the continental US and Canada.

5. WHAT IS COVERED UNDER THIS WARRANTY:
Defects on the manufacturer's material and workmanship of product under normal use, and which occur within the duration of the warranty period. On all awnings, the following parts are covered only as follows:
a) Fabrics, free from quality defects (normal wear and fading are excluded);
b) Roller Tube, against extrusion defects;
c) Springs (or Motor) Assembly(ies), against breakage; and
d) Hardware, against extrusion defects.

6. WHAT IS NOT COVERED UNDER THIS WARRANTY:
A. Fabric damage such as pinholes or tears not reported within ten (10) calendar days of purchase;
B. Improper installation and/or any damage or failure that results from improper installation of the product, including fabric damage caused by improper installation;
C. Product abuse and normal wear. "Normal wear" includes the occasional need to re-tension the awning;

D. Conditions that are not related to the material or workmanship of the product: including any failure that results from an accident, wind, rain, water pooling, or other acts of God; purchaser's abuse; neglect; failure to operate, or use or maintain the product in accordance with the instructions provided in the Owner's Manual supplied with the product; (failure to operate the product(s) in accordance with instructions in the Owner's Manual and on the product shall also include the removal or alteration of any product component or device. In the event of any such removal or alteration, this warranty is void);

E. ANY INCIDENTAL, INDIRECT, OR CONSEQUENTIAL LOSS, DAMAGE, OR EXPENSE THAT MAY RESULT FROM ANY DEFECT, FAILURE, OR MALFUNCTION OF THE CAREFREE OF COLORADO PRODUCT. Some states do not allow the exclusion or limitation on incidental or consequential damages, so the above limitation or exclusion may not apply to you.

F. Any failure that results from the use of another product with a Warrantor's product that is not specifically approved by the Warrantor.

7. RESPONSIBILITIES OF WARRANTOR UNDER THIS WARRANTY: Repair or replace at Warrantor's option, of the covered part(s) which Warrantor, in the exercise of its reasonable discretion, determines to be defective; provided that the Warrantor receives notice of the defect within the stated warranty period for that respective product/component. Warrantor will also pay the respective servicing dealer or agent for performing any repairs authorized by Warrantor as per the terms of this warranty.

8. RESPONSIBILITIES OF ORIGINAL PURCHASER UNDER THIS WARRANTY:

A. Retain dated Proof of Purchase for specific product, and provide it as requested.

B. Inspect the awning upon purchase to confirm the condition of the canopy and the proper operation of the product.

C. Perform "Periodic Preventative Maintenance" as specified in Owners Manual.

D. Deliver any product claimed or found defective during warranty period to the nearest Carefree of Colorado Authorized Service Dealer. The Original Purchaser is responsible for any expenses related to delivery or pick up of product to/from the Service Dealer. Visit carefreeofcolorado.com for the name of nearest Authorized Service Dealer, or call Carefree at the phone number shown above.

E. Use reasonable care in the operation and maintenance of the products as described in the Owner's Manual supplied with the product(s).

9. WHEN WARRANTOR WILL PERFORM REPAIR OR REPLACEMENT UNDER WARRANTY.

A. Repair or replacement will be scheduled and performed according to normal work flow at the nearest Authorized Service Dealer, and depending on the availability of replacement parts.

B. If the purchaser does not receive satisfactory results from the Authorized Service Dealer, the purchaser should contact the Carefree of Colorado Customer Service Department (see paragraph 2).

THIS WARRANTY GIVES YOU SPECIFIC LEGAL RIGHTS AND YOU MAY ALSO HAVE OTHER RIGHTS WHICH VARY FROM STATE TO STATE. No action to enforce this warranty shall be commenced later than 30 days expiration of the warranty period.

The Duration of this Limited Warranty also limits the duration of any implied warranty such as warranty of merchantability or fitness for a particular use or purpose. Some states do not allow such limitations so the implied warranty limitation may not apply to you.

Carefree of Colorado reserves the right to change the specifications and design of any product without notice and with no obligation to make corresponding changes to products previously manufactured.

**ONE-TOUCH PATIO AWNING
TROUBLE SHOOTING CHARTS
TABLE OF CONTENTS**

PAGE NO.

AWNING WON'T ROLL OUT/IN ELECTRICAL.....

AWNING WON'T ROLL OUT/IN MECHANICAL.....

AWNING ROLLS IN OR OUT UNEVENLY.....

RAFTER WILL NOT FULLY EXTEND.....

AWNING RETRACTS MORE THAN 30 SECONDS.....

TOOLS NEEDED

- 1. VOLT/OHM METER**
- 2. PHILIPS SCREWDRIVER**
- 3. 9/64" ALLEN WRENCH**

ONE-Touch 12Volt Patio Awning Troubleshooting

AWNING WON'T ROLL OUT/IN

(ELECTRICAL)

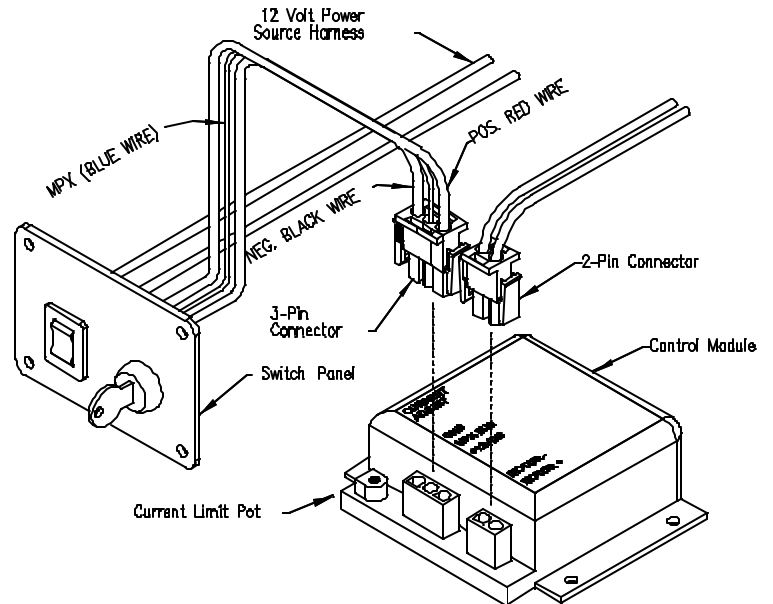
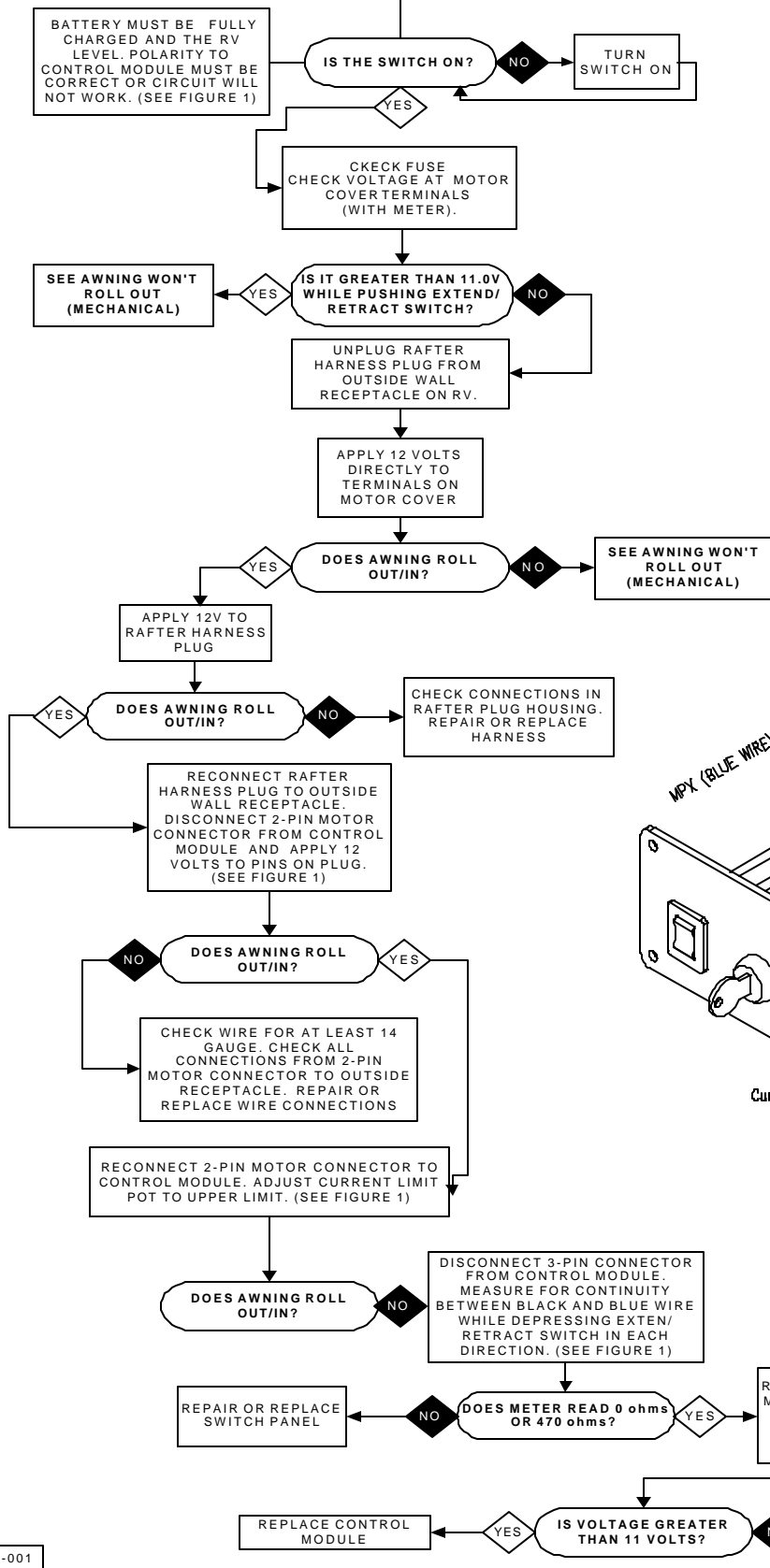
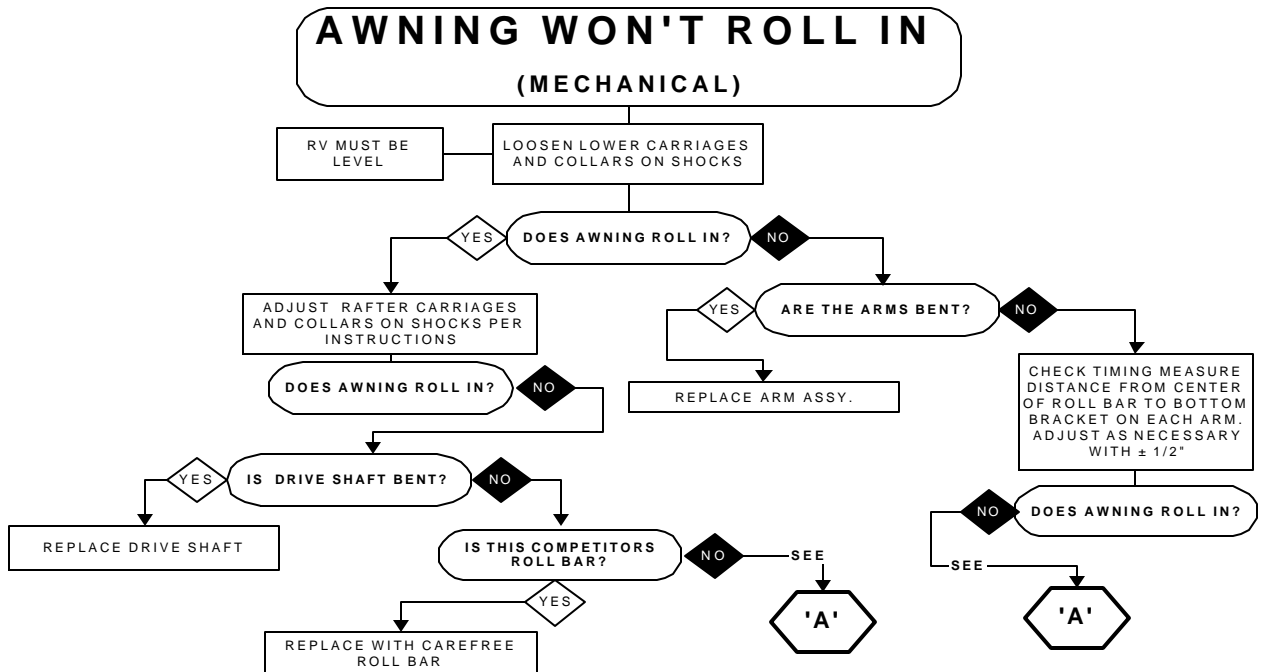
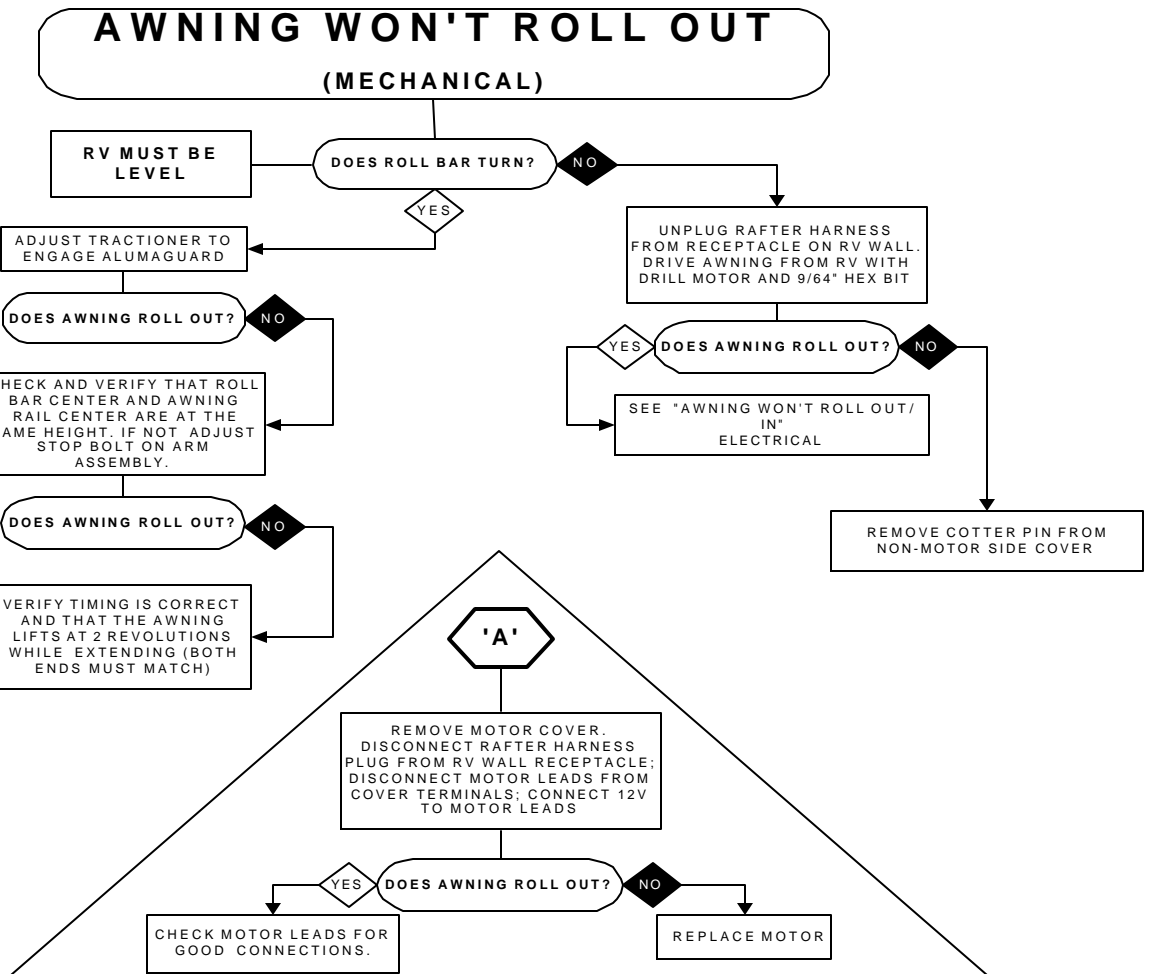

FIGURE 1

ONE-Touch 12Volt Patio Awning Troubleshooting



ONE-Touch 12Volt Patio Awning Troubleshooting

AWNING ROLLS IN OR OUT UNEVENLY (MECHANICAL)

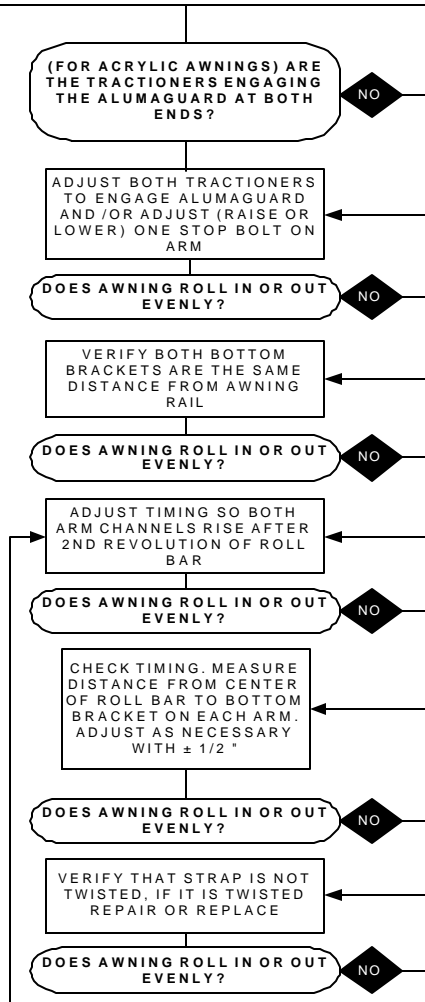

ONE-Touch 12Volt Patio Awning Troubleshooting

RAFTER WILL NOT FULLY EXTEND (MECHANICAL)

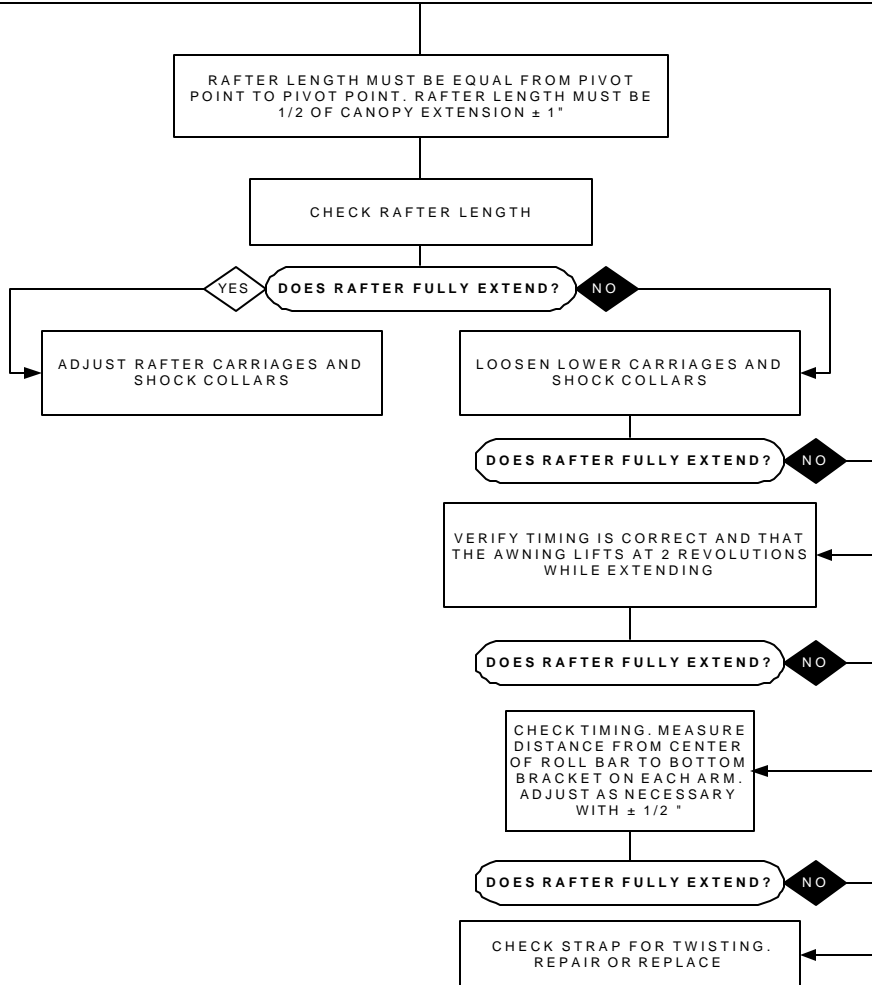

ONE-Touch 12Volt Patio Awning Troubleshooting

AWNING RETRACTS MORE THAN 30 SECONDS (ELECTRICAL)

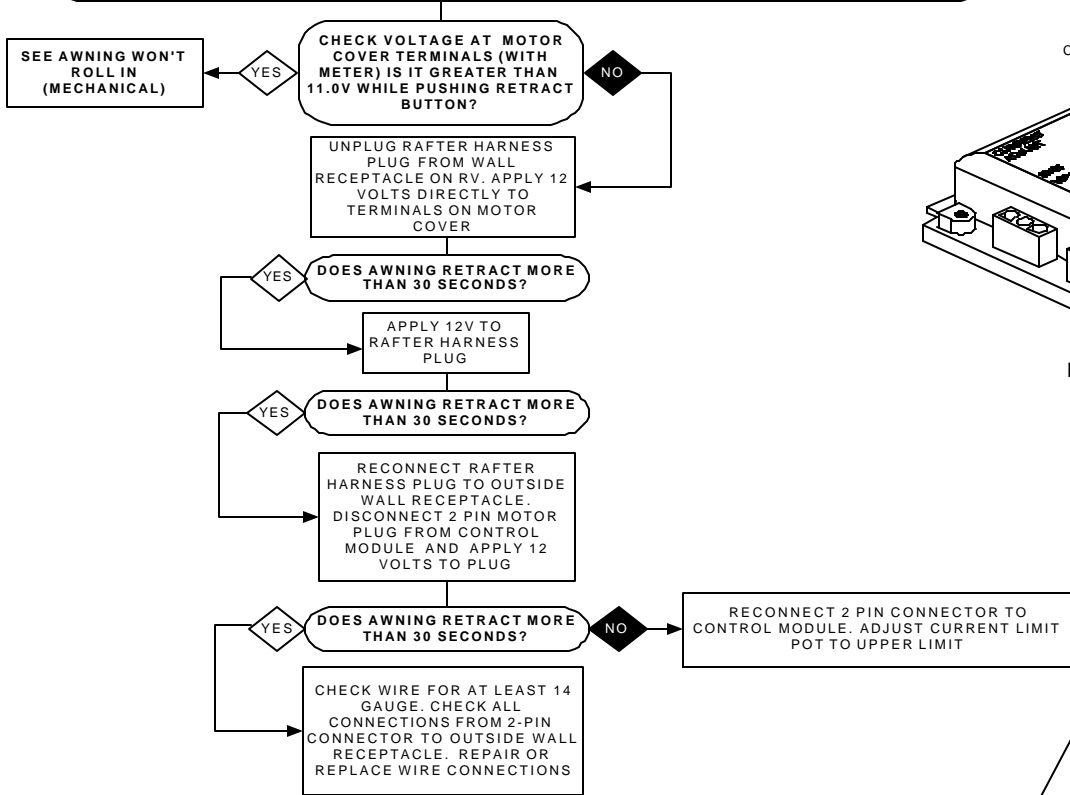

CONTROL MODULE

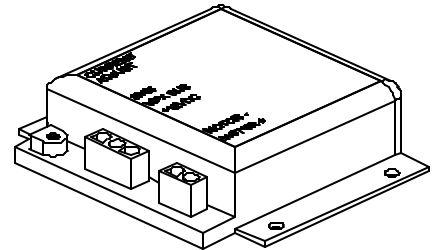

FIGURE 2

AWNING RETRACTS MORE THAN 30 SECONDS (MECHANICAL)

